

# Core Heaters

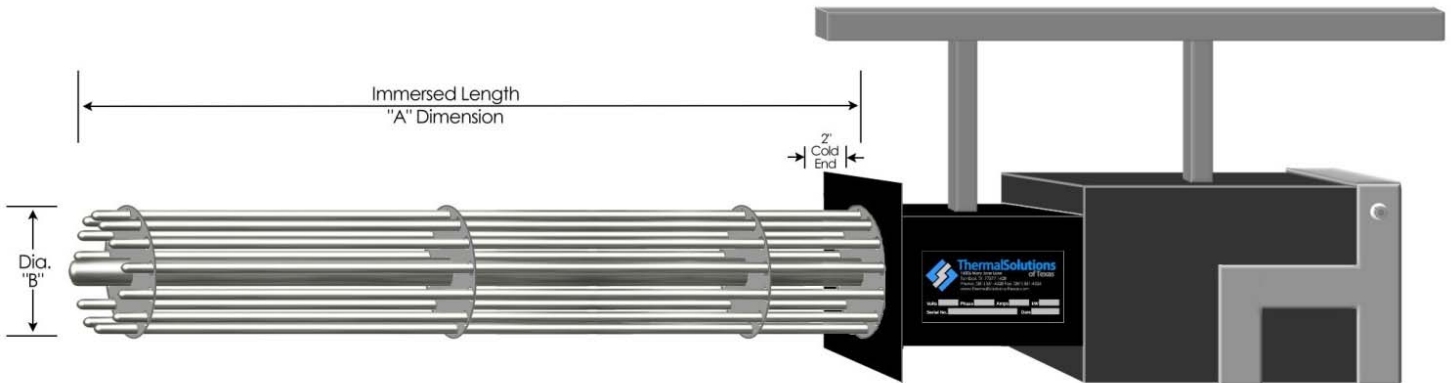

Core heaters are used to heat and/or maintain temperatures of the inside diameter of pipes and various drilling tool applications.

## Features:

- 240VAC or 480VAC models available
- Watt densities up to 20W/in<sup>2</sup> max per element
- Precision wound nickel-chromium resistance wire – distributes evenly to the sheath for optimum heater performance
- Various diameters and lengths available
- Process / Hi-Limit thermocouples available
- Elements are individually replaceable
- Alloy 800 Sheath material
- Element sheath temperatures capable of temperatures up to 1200°F
- Silicone resin end seals – protects against moisture contamination
- MgO insulation filled sheath – maximizes dielectric strength, heat transfer and life
- Handle for easy insertion and removal

## Accessories:

- Insulation Blankets
- Power Extension Cables
- Thermocouple Extension Cables
- Temperature Control Panel

