

DATE: _____ CUSTOMER: _____
 PHONE: _____ CONTACT: _____
 FAX: _____ EMAIL: _____

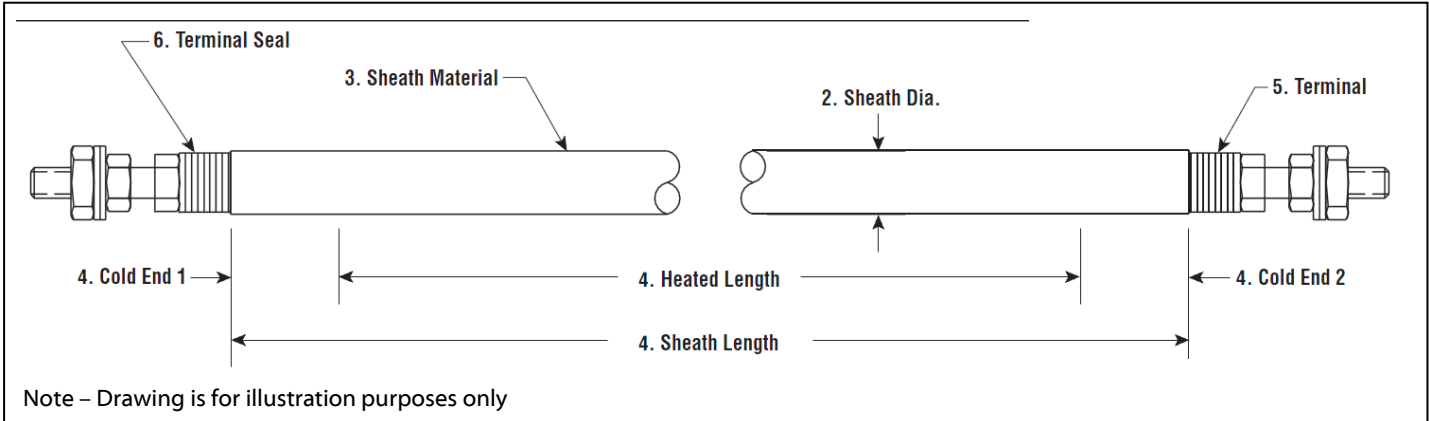

Operating Conditions

APPLICATION (Describe in Detail):

HEATED MEDIUM: Gas Liquid Solid **OPERATING PRESSURE:** psig
INSTALLATION ENVIRONMENT: Indoor Outdoor Hazardous Class Div Group
MAX WORK TEMP: °F **MAX SHEATH TEMPERATURE:** °F **AMBIENT TEMPERATURE:** °F

Heater Specifications (Check All That Apply)

RATING:	Volts		Watts					
ELEMENT DIA. (IN):	<input type="checkbox"/> 0.20	<input type="checkbox"/> 0.246	<input type="checkbox"/> 0.315	<input type="checkbox"/> 0.375	<input type="checkbox"/> 0.43	<input type="checkbox"/> 0.475	<input type="checkbox"/> 3/8HS	<input type="checkbox"/> 1/2HS
SHEATH MATERIAL:	<input type="checkbox"/> Copper		<input type="checkbox"/> Incoloy	<input type="checkbox"/> Stainless Steel		<input type="checkbox"/> Steel	<input type="checkbox"/> Other (Specify):	
LENGTH: (Inches)	<input type="checkbox"/> Sheath		<input type="checkbox"/> Heated End					
	<input type="checkbox"/> Cold End 1		<input type="checkbox"/> Cold End 2					
TERMINATIONS:	Double End:		<input type="checkbox"/> Threaded	<input type="checkbox"/> Screw Lug Plate		<input type="checkbox"/> Leads	<input type="checkbox"/> Quick Connect Spade	
	Single End:		<input type="checkbox"/> Flexible Lead Wires			<input type="checkbox"/> Lead Wire Rubber Overmolds		
TERMINALS:	<input type="checkbox"/> Double End		<input type="checkbox"/> Single End			<input type="checkbox"/> Other (Specify):		
TERMINAL SEALS:	<input type="checkbox"/> Standard Epoxy (194°F)		<input type="checkbox"/> Intermed. Epoxy (356°F)		<input type="checkbox"/> High Temp Epoxy (450°F)			
	<input type="checkbox"/> Silicone Resin(221°F)		<input type="checkbox"/> Silicone Fluid (392°F)		<input type="checkbox"/> Silicone RTV (392°F)			
	<input type="checkbox"/> Lavacone (221°F)		<input type="checkbox"/> Ultragard (707°F)		<input type="checkbox"/> HT Ceramic (2800°F)			
MOUNTING:	<input type="checkbox"/> Loc. Washers	<input type="checkbox"/> Brackets		<input type="checkbox"/> Single Leg Bracket		<input type="checkbox"/> Mounting Collars		
	<input type="checkbox"/> Bulkheads:		Material	Thread Size	Thread Length	Location		
	<input type="checkbox"/> Staked on		<input type="checkbox"/> Brazed	<input type="checkbox"/> Welded				
APPROVALS:	<input type="checkbox"/> None		<input type="checkbox"/> UL	<input type="checkbox"/> CSA Certified				
BEND FORMATIONS	SEE ATTACHED PAGE							

FIGURE 1

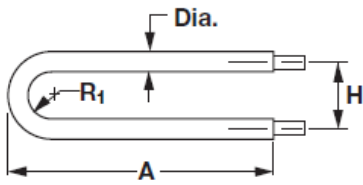

$$SL = 2A + 1.14R_1 - 0.43 \text{ Dia.}$$

FIGURE 2

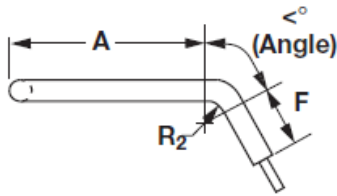

$$SL = 2A + 2F + 1.14R_1 + 0.0175(\angle) (2R_2 + \text{Dia.}) - 0.43 \text{ Dia.}$$

FIGURE 3

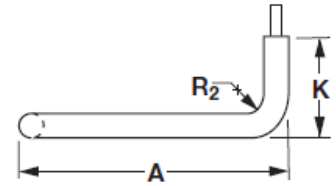

$$SL = 2K - 0.86R_2 - 2.86 \text{ Dia.} + 2A + 1.14R_1$$

FIGURE 4

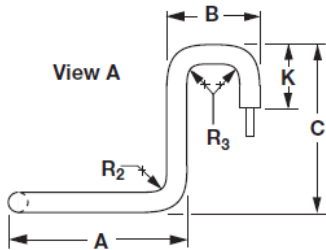

$$SL = 2K - 1.72R_3 - 7.72 \text{ Dia.} + 2C - 0.86R_2 + 2A + 1.14R_1$$

View B

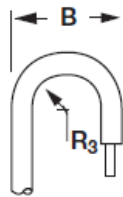

$$SL = 2K - 2.28R_3 - 3.72 \text{ Dia.} + 2C - 0.86R_2 + 2A + 1.14R_1$$

FIGURE 5

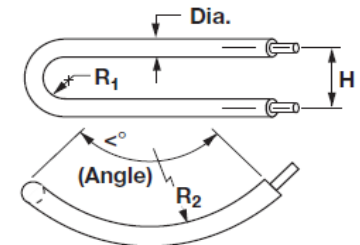

$$SL = 0.0175(\angle) (2R_2 + \text{Dia.}) + 1.14R_1 + 0.43 \text{ Dia.}$$

FIGURE 6

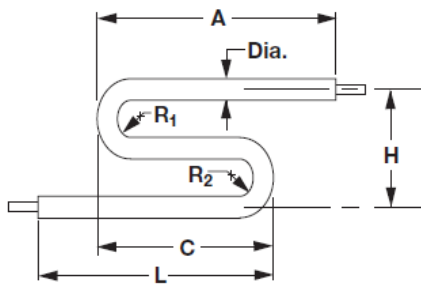

$$SL = L + 1.14R_2 - 0.86 \text{ Dia.} + C + 1.14R_1 + A$$

FIGURE 7

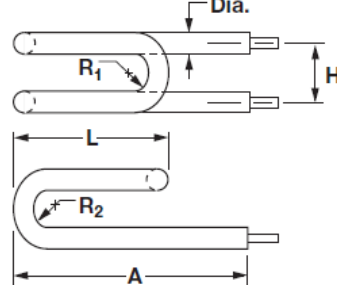

$$SL = 2A + 2.28R_2 - 1.29 \text{ Dia.} + 2L + 1.14R_1$$

FIGURE 8

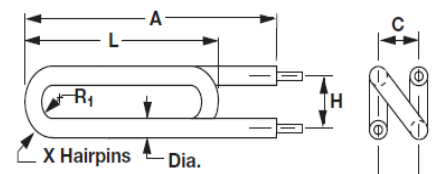

$$SL = 2A + 3.42R_1 - 1.29 \text{ Dia.} + 2L$$

FIGURE 9

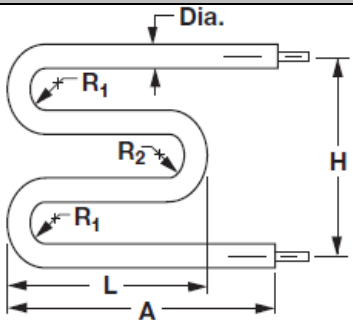

$$SL = 2A + 2.28R_1 - 1.29 \text{ Dia.} + 2L + 1.14R_2$$

FIGURE 10

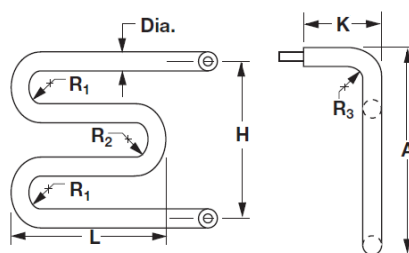

$$SL = 2K - 0.86R_3 - 3.72 \text{ Dia.} + 2A + 2L + 2.28R_1 + 1.14R_2$$

FIGURE 11

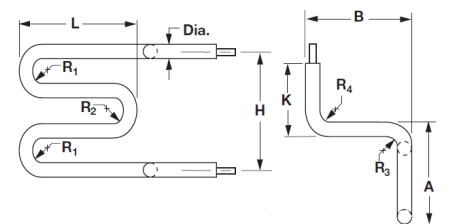

$$SL = 2K - 0.86R_3 - 0.86R_4 - 6.15 \text{ Dia.} + 2B + 2A + 2L + 2.28R_1 + 1.14R_2$$

FIGURE 12

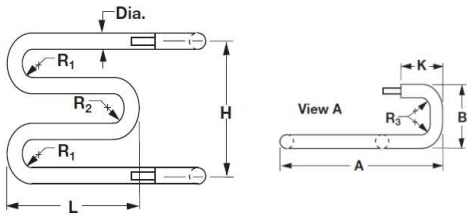

$$SL = 2K + 2B + 2A + 2L + 25.28R_1 + 1.14R_2 - 1.72R_3 - 6.15 \text{ Dia.}$$

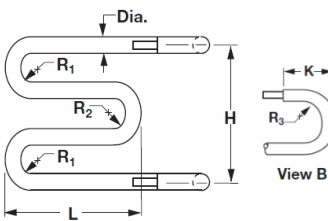

$$SL = 2K + 2A + 2L + 2.28R_1 + 1.14R_2 - 2.28R_3 - 2.15 \text{ Dia.}$$

FIGURE 13

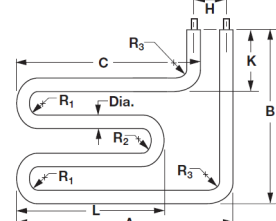

$$SL = 2B + 2A + 2L - 6.717 \text{ Dia.} - 1.717R_1 - H - 0.858R_2 - 0.858R_3$$

FIGURE 14

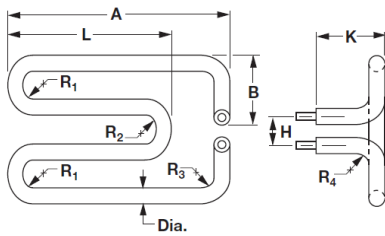

$$SL = 2B + 2A + 2L - 6.717 \text{ Dia.} - 1.717R_1 - H - 0.858R_2 - 0.858R_3$$

FIGURE 15

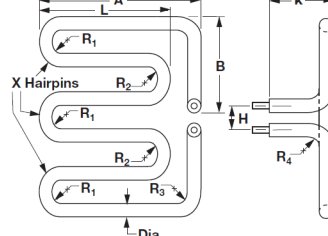

$$SL = 2K + 2A + 2K(X - 1) + 2B - 0.86R_3 - 0.86R_4 + 1.14R_1(X) + 1.14R_2(X - 1) - 4.86 \text{ Dia.} - (2X - 1) 0.43 \text{ Dia}$$

FIGURE 16

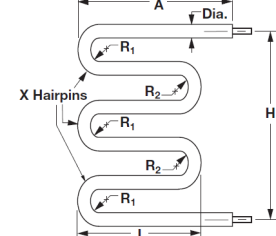

$$SL = 2A + 0.43 \text{ Dia.} (1 - 2X) + 2L(X - 1) + 1.14R_1 + 1.14R_2(X - 1)$$

FIGURE 17

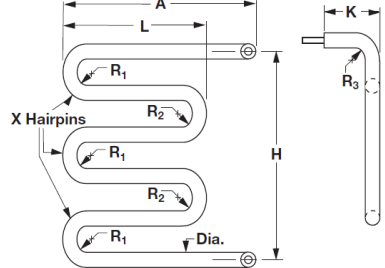

$$SL = 1.14R_2 X - 0.88 \text{ Dia.} - X - 1.14R_2 - 2 \text{ Dia.} + 1.14R_1 X - 0.86R_3 + 2L X - 2L + 2A + 2K$$

FIGURE 18

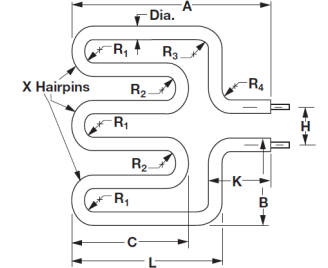

$$SL = 2L + 2K + 2B + 2C(X - 1) - 0.86R_3 - 0.86R_4 - 4.86 \text{ Dia.} + 1.14R_1(X) + 1.14R_2(X - 1) - (2X - 1) 0.43 \text{ Dia.}$$

FIGURE 19

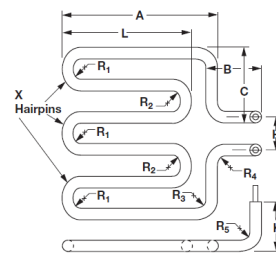

$$SL = 2K + 2A + 2B + 2C + 2L(X - 1) + 1.14R_1(X) + 1.14R_2(X - 1) - 0.86R_3 - 0.86R_4 - 0.86R_5 - 7.29 \text{ Dia.} - (2X - 1) 0.43 \text{ Dia.}$$

FIGURE 20

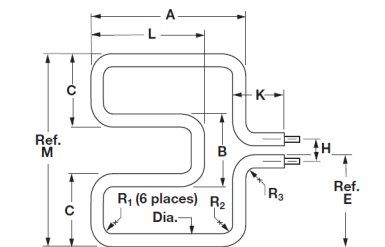

$$SL = 2K + 2C + B + 2A + 2L - 2.58R_1 - 0.86R_2 - 0.86R_3 - 12.15 \text{ Dia.}$$

FIGURE 21

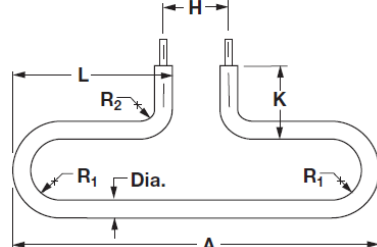

$$SL = 2A + 2K - H - 2.28R_1 - 0.86R_2 - 3.29 \text{ Dia.}$$

FIGURE 22

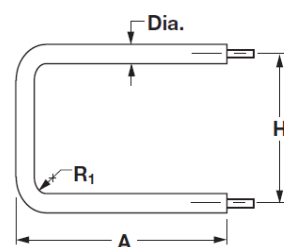

$$SL = 2A - 0.86R_1 - 1.43 \text{ Dia.} + H$$

FIGURE 23

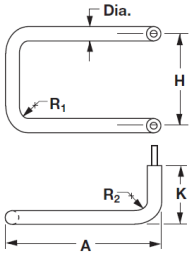

$$SL = 2K - 0.86R_2 - 3.86 \text{ Dia.} + 2A - 0.86R_1 + H$$

FIGURE 24

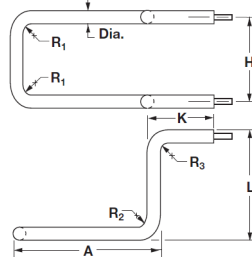

$$SL = 2K + 2L + H - 0.86R_1 - 0.86R_2 - 0.86R_3 - 7.29 \text{ Dia.}$$

FIGURE 25

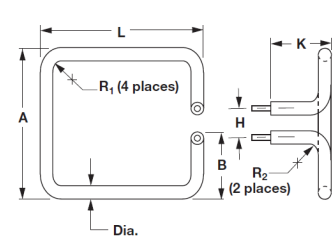

$$SL = 2K + 2A + 2L - H - 1.72R_1 - 0.86R_2 - 6.92 \text{ Dia.}$$

FIGURE 26

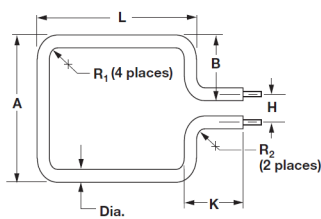

$$SL = 2K + 2A + 2L - H - 1.72R_1 - 0.86R_2 - 6.29 \text{ Dia.}$$

FIGURE 27

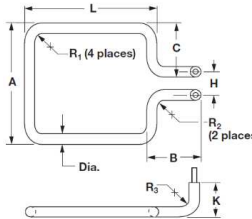

$$SL = 2K + 2A + 2L + 2B - H - 1.72R_1 - 1.72R_2 - 8.72 \text{ Dia.}$$

FIGURE 28

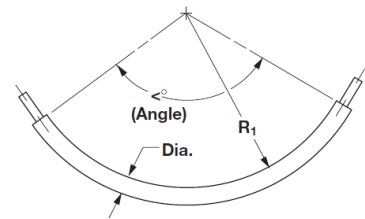

$$SL = 0.0175 <^\circ (R_1 + 0.5 \text{ Dia.})$$

FIGURE 29

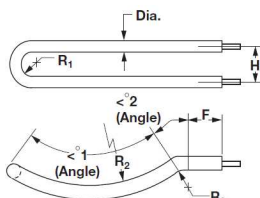

$$SL = 0.0175 <^\circ 1 (2R_2 + \text{Dia.}) + 2F + 1.14R_1 + 0.0175 <^\circ 2 (2R_3 + \text{Dia.}) - 0.43 \text{ Dia.}$$

FIGURE 30

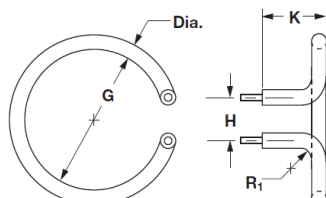

$$SL = (G + \text{Dia.}) 3.14 + 1.14R_1 + 2K + 3.28 \text{ Dia.} - H$$

FIGURE 31

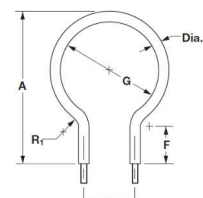

$$SL = (G + \text{Dia.}) 3.14 + 1.14R_1 + 2F + 3.71 \text{ Dia.} - H$$

FIGURE 32

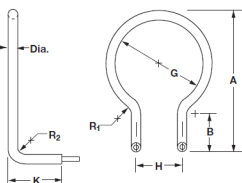

$$SL = (G + \text{Dia.}) 3.14 + 1.14R_1 + 2B + 1.14R_2 + 2K + 3.28 \text{ Dia.} - H$$

FIGURE 37

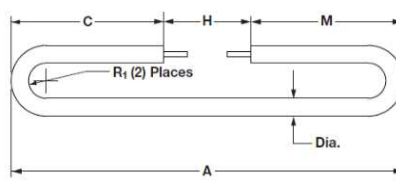

$$SL = (2A - H) + 2\pi R_1 - 2R_1$$

FIGURE 38

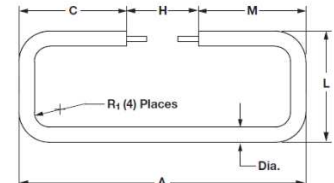

$$SL = (2A - H) + 2L + 2\pi R_1 - 4R_1$$

FIGURE 39

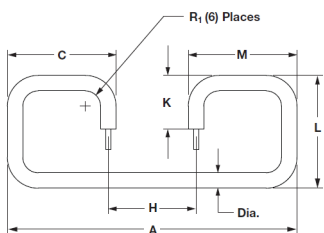

$$SL = (2A - H) + 2L + 2K + 3\pi R_1 - 6R_1$$

FIGURE 40

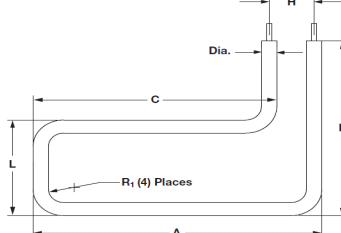

$$SL = (2A - H) + 2B + 2\pi R_1 - 4R_1$$

FIGURE 41

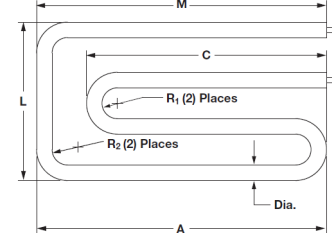

$$SL = 2A + 2C + L - H + 2\pi R_1 + \pi R_2 - 2R_1 - 2R_2$$

FIGURE 42

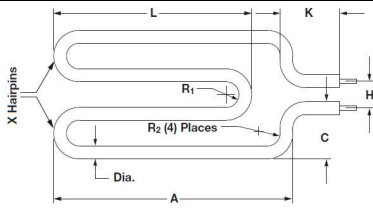

$$SL = 2A + (\#)L + 2K + 2C + 2\pi R_2 + (\# \text{ of } R_1) \pi R_1 - (\# \text{ of } R_1) R_1$$

FIGURE 43

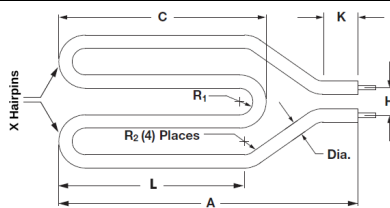

$$SL = 2A + (\#)C + (\# \text{ of } R_1) \pi + 2\pi R_2 - (\# \text{ of } R_1) R_1 - 4R_2$$

FIGURE 44

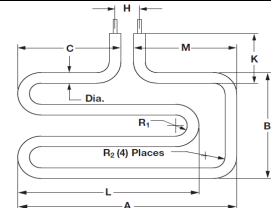

$$SL = 2A + 2L + B + 2K + 2\pi R_2 + 3\pi R_1 - 4R_2 - 3R_1$$

FIGURE 45

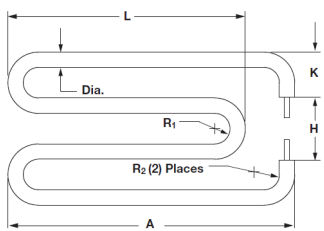

$$SL = 2A + 2L + 2K + 3\pi R_1 + \pi R_2 - 3R_1 - 2R_2$$

FIGURE 46

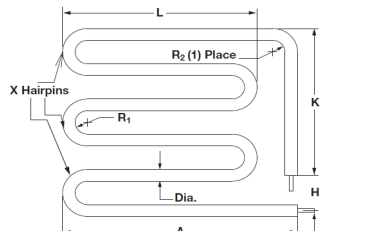

$$SL = 2A + (\#)L + K + (\# \text{ of } R_1) \pi + ((\pi R_2)/2) - (\# \text{ of } R_1) R_1 - R_2$$

FIGURE 47

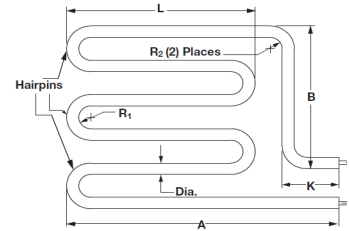

$$SL = 2A + (\#)L + B + K + (\# \text{ of } R_1) \pi + \pi R_2 - (\# \text{ of } R_1) R_1 - 2R_2$$

FIGURE 48

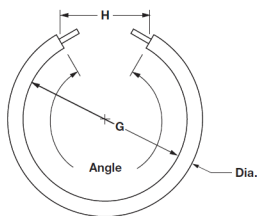

$$SL = \pi G - H$$

FIGURE 49

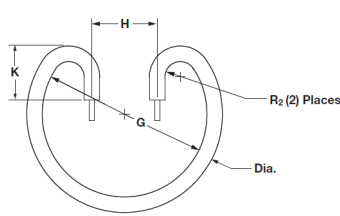

$$SL = \pi G - H + 2K + 2\pi R_2 - 2R_2$$

FIGURE 50

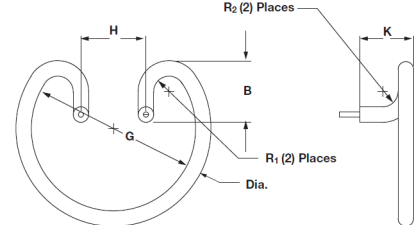

$$SL = \pi G - H + 2B + 2K + \pi R_2 + 2\pi R_1 - 2R_1 - 2R_2$$

FIGURE 51

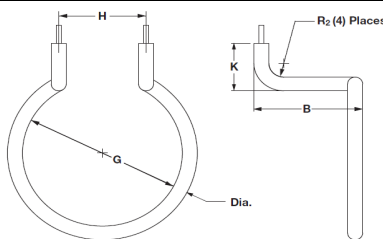

$$SL = \pi G - H + 2B + 2K + 2\pi R_2 - 4R_2$$

FIGURE 52

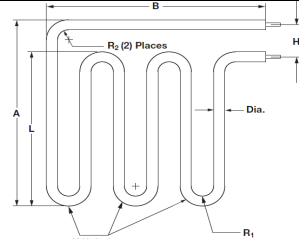

$$SL = 2A + B + (\#)L - H + (\# \text{ of } R_1) \pi + \pi R_2 - (\# \text{ of } R_1) R_1 - 2R_2$$

FIGURE 53

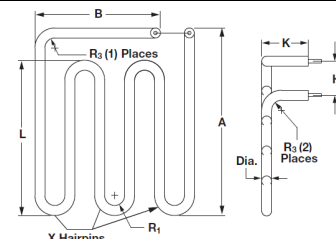

$$SL = 2A + (\#)L + B + 2K + (\# \text{ of } R_1) \pi + 3((\pi R_2)/2) - (\# \text{ of } R_1) R_1 - 3R_2$$

FIGURE 54

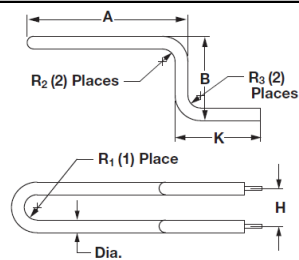

$$SL = 2A + 2B + 2K + \pi R_1 + 2\pi R_2 - R_1 - 4R_2$$

FIGURE 55

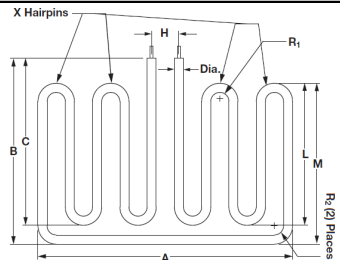

$$SL = A + 2C + 2M + (\#)L + (\# \text{ of } R_1) \pi + \pi R_2 - (\# \text{ of } R_1) R_1 - 2R_2$$

