

Cartridge/Insertion Heaters

MULTICELL Heaters

The advanced design of the MULTICELL insertion heater from Watlow® offers three major advantages: extreme process temperature capability, independent zone control for precise temperature uniformity and loose fit design for easy insertion and removal.

Performance Capabilities

- Engineered to achieve sheath temperatures up to 2050°F (1120°C)
- Up to eight independently controllable zones

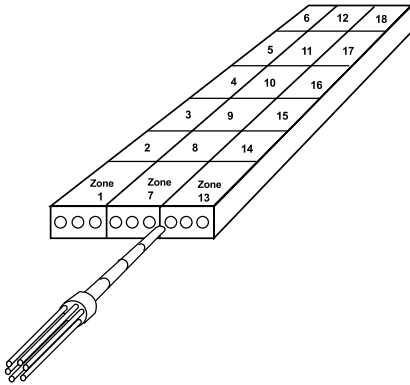

Features and Benefits

Multiple, independently controllable zones

- Allows process temperature uniformity not possible with any other single sheathed heater

Radiant design of heater

- Allows for loose insertion in boiling holes and piping holes
- Permits easy removal and replacement with minimal down time since it will not bind or seize in the hole

Oxidized sheath

- Provides high emissivity and improves the heater's performance as oxidation increases

Individually metal-sheathed coils swaged into a larger, high temperature alloy outer sheath

- Provides maximum protection against element burnout through the outer sheath

Quick disconnect plug and jack

- Permits fast replacement of individual elements while the press stays at operating temperature

Special bending capabilities

- Solves unusual machinery needs and keeps leads away from heated zones

Flexible leads up to 986°F (530°C)

- Protects termination from high temperature environment

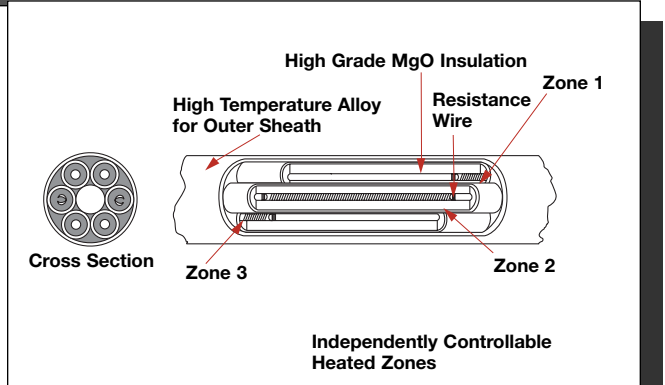

Applications

- Hot isothermal forming
- Soil remediation
- Hot forging dies
- Heated platens
- Super plastic forming
- Heated platens (single and multiple zones)
- Heat treating processes
- Super plastic forming with diffusion bonding

Cartridge/Insertion Heaters

MULTICELL Heaters

Applications and Technical Data

Definition of Terms

Cold Toe: A physical minimum requirement of $1\% \pm \frac{5}{16}$ inch

Independent Zone: Up to three, separately controlled zones which can be of varying lengths and wattages

Heated Length: The combined sum of all independent zones

Wattage: Ratings are the combined sum of all independent zones

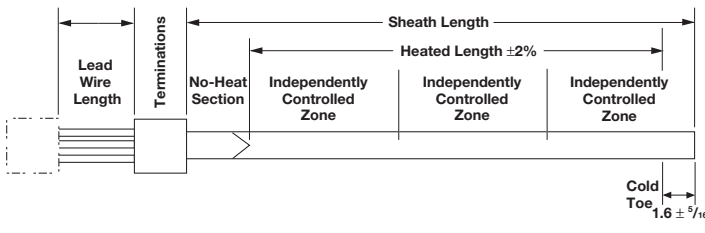

MULTICELL Heaters: The High Temperature Choice

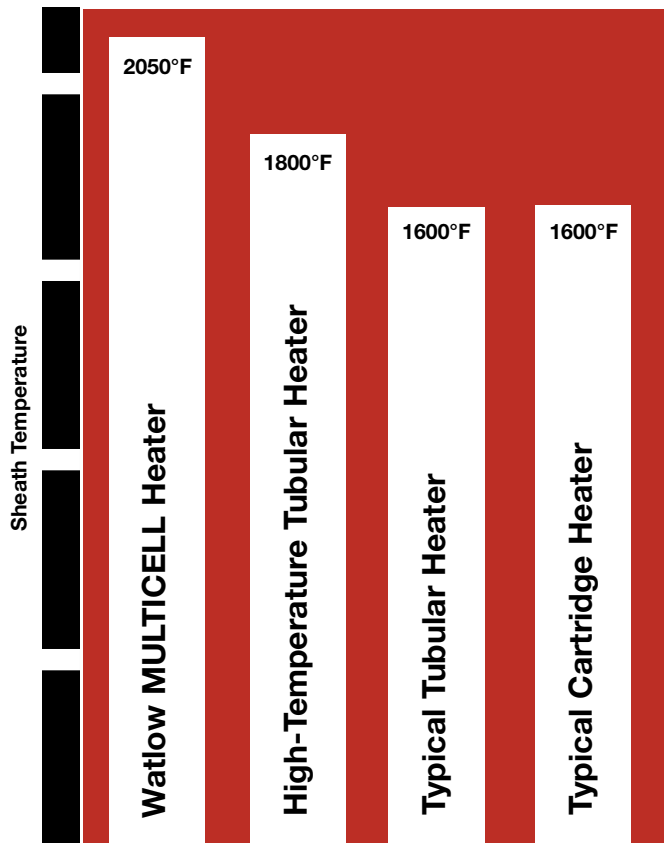

Maximum Allowable Watt Density Single Zone ①

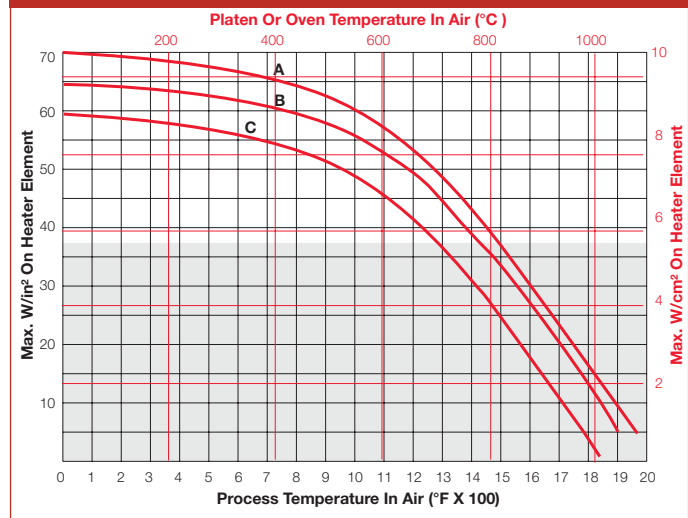

Maximum Allowable Watt Density Three Zone ①

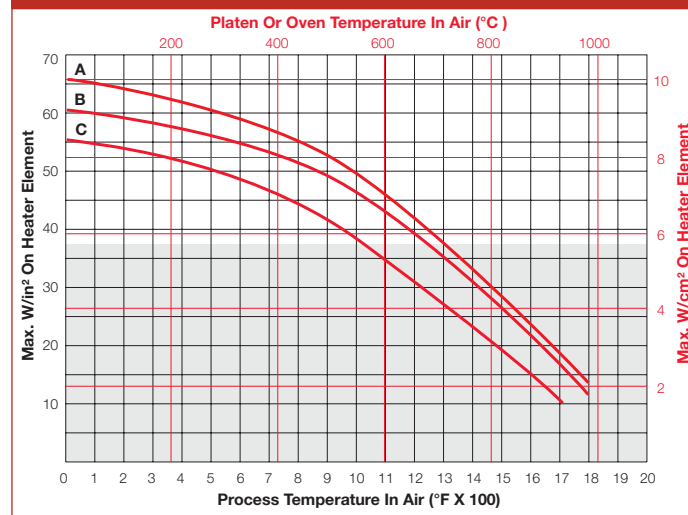

- A = 6 cell, 0.935 in. diameter, 240V~(ac), 3-phase
- B = 6 cell, 0.685 in. diameter, 240V~(ac), 3-phase
- C = 6 cell, 0.935 in. diameter, 480V~(ac), 3-phase

Note: Shaded area is standard, non-shaded area contact your Watlow representative.

① Other designs and voltages with higher temperature capabilities are available. Contact your Watlow representative.

Cartridge/Insertion Heaters

MULTICELL Heaters

Applications and Technical Data (Continued)

Physical Design Parameters

All bending of a MULTICELL heater is restricted to the cold area of the heater. All bend radii points must be 1 in. (25 mm) from the hot/cold junction.

“L”

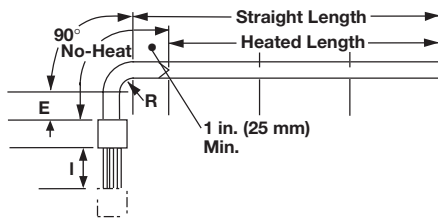

Droop

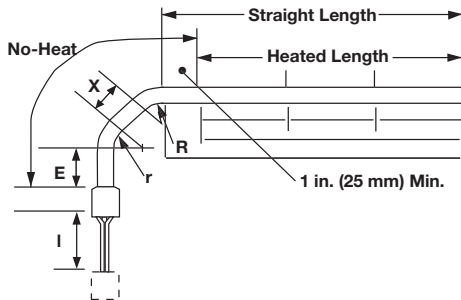

Straight

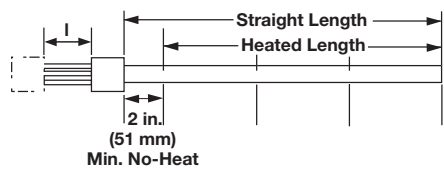

Angle

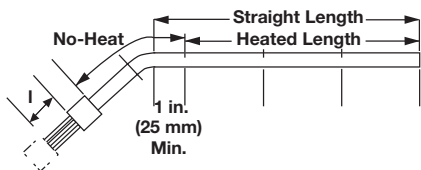

Crank

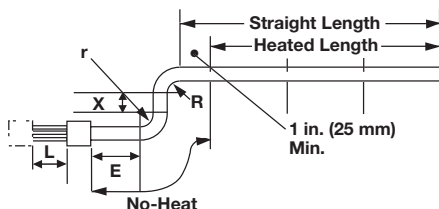

0.935 Inch Diameter MULTICELL Heater

Diameter in.	Bending Style	Sheath Length		Min. No-Heat Length		Total Heated Length	
		Min./Max. in. (mm)	in. (mm)	in. (mm)	Min./Max. in. (mm)		
0.935	Straight	14 (356)	Contact Watlow	6 (152.0)	6 (152.0)		
		225 (5715)	Contact Watlow	160 (4064.0)	160 (4064.0)		
0.935	Angle	17 (432)	Contact Watlow	6 (152.0)	6 (152.0)		
		225 (5715)	Contact Watlow	172½ (4382.0)	172½ (4382.0)		
0.935	L	18 (457)	Contact Watlow	6 (152.0)	6 (152.0)		
		225 (5715)	Contact Watlow	170¾ (4324.4)	170¾ (4324.4)		
0.935	Crank	23 (584)	Contact Watlow	6 (152.0)	6 (152.0)		
		225 (5715)	Contact Watlow	163 (4140.0)	163 (4140.0)		
0.935	Droop	18 (457)	Contact Watlow	6 (152.0)	6 (152.0)		
		225 (5715)	Contact Watlow	168 (4267.0)	168 (4267.0)		

Symbol	E	r	X	R	I
Min. Length in. (mm)	4 (102)	2½ (38)	1½ (38)	2½ (38)	12 (305)

Zones	1	2	3
Min. Heated in. (mm)	6 (152)	6 (152)	6 (152)

0.685 Inch Diameter MULTICELL Heater

Diameter in.	Bending Style	Sheath Length		Min. No-Heat Length		Total Heated Length	
		Min./Max. in. (mm)	in. (mm)	in. (mm)	Min./Max. in. (mm)		
0.685	Straight	14 (356)	Contact Watlow	6 (152)	6 (152)		
		225 (5715)	Contact Watlow	178 (4521)	178 (4521)		
0.685	Angle	17 (432)	Contact Watlow	6 (152)	6 (152)		
		225 (5715)	Contact Watlow	173½ (4407)	173½ (4407)		
0.685	L	18 (457)	Contact Watlow	6 (152)	6 (152)		
		225 (5715)	Contact Watlow	172 (4369)	172 (4369)		
0.685	Crank	18 (457)	Contact Watlow	6 (152)	6 (152)		
		225 (5715)	Contact Watlow	163 (4267)	163 (4267)		
0.685	Droop	15½ (394)	Contact Watlow	6 (152)	6 (152)		
		225 (5715)	Contact Watlow	170 (4331)	170 (4331)		

Symbol	E	r	X	R	I
Min. Length in. (mm)	4 (102)	1½ (38)	1½ (38)	1½ (38)	12 (305)

Zones	1	2	3
Min. Heated in. (mm)	6 (152)	6 (152)	6 (152)

Cartridge/Insertion Heaters

MULTICELL Heaters

Applications and Technical Data (Continued)

Tab Styles

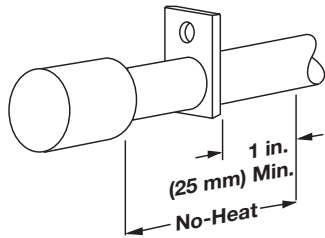

Full View

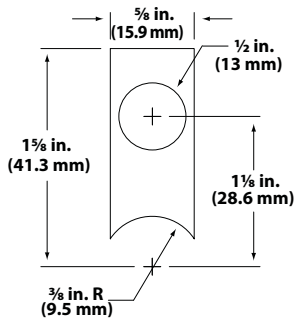
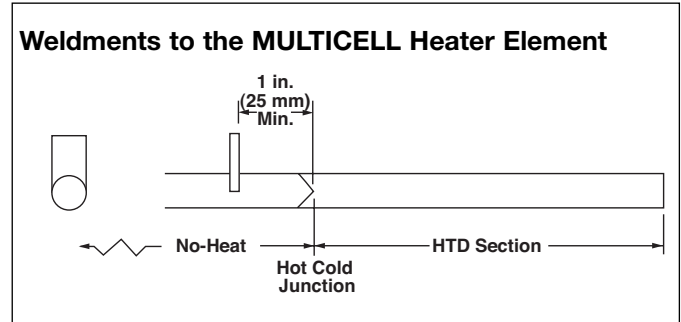

Style S1

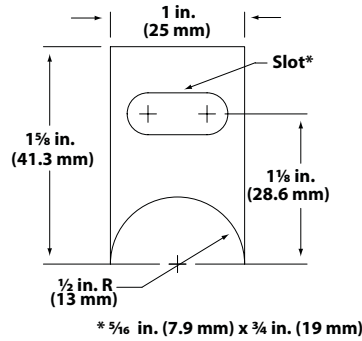

Style S2

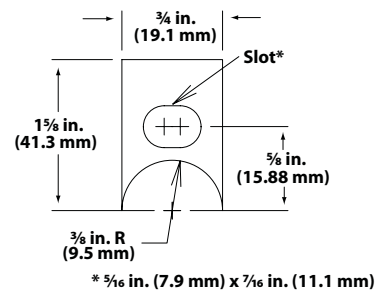

Style S3

Tabs and rings are used to hold the heater in place and keep it from creeping.

Ring Styles

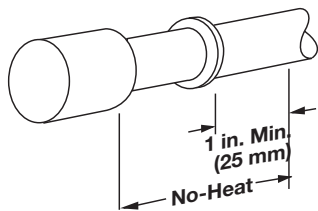

Full View

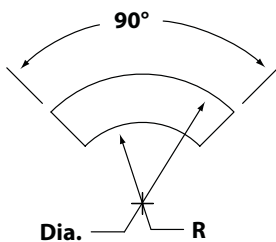

Style S4

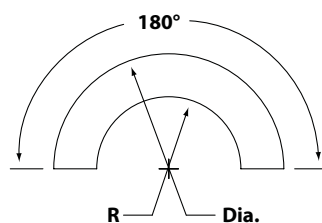

Style S5

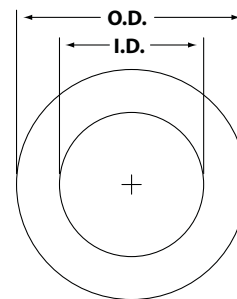

Style H1

Cartridge/Insertion Heaters

MULTICELL Heaters

Termination Standards

Potting Sleeves

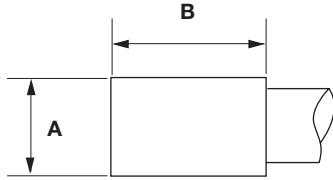

Heater O.D. in.	Dimension A in. (mm)	Dimension B in. (mm)	Zone	Phase	Type No.
0.685	3/4 (19)	1 1/2 (38)	1	1	61L
0.935	1 1/16 (27)	1 1/2 (38)	1	1	91L
0.935	1 1/16 (27)	1 1/2 (38)	1	3 [Ⓞ]	91L

① 3 wire only

Ceramic Wedge with 10-32 Threaded Terminals

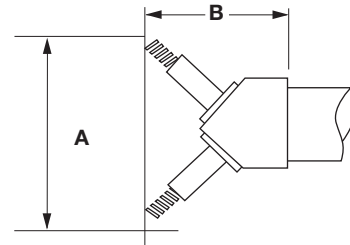

Heater O.D. in.	Dimension A in. (mm)	Dimension B in. (mm)	Zone	Phase	Type No.
0.685	1 1/4 (32.0)	1 1/4 (32.0)	1	1	61T
0.935	1 1/8 (41.3)	1 1/8 (41.3)	1	1	91T

Potting Cups

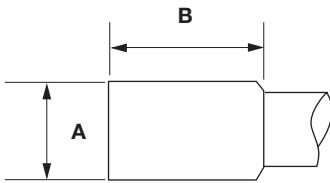

Heater O.D. in.	Dimension A in. (mm)	Dimension B in. (mm)	Zone	Phase	Type No.
0.685	1 1/8 (34.9)	1 1/8 (34.9)	2	1	62L
0.685	1 1/8 (34.9)	1 1/8 (34.9)	3	1	62L
0.685	1 1/8 (34.9)	1 1/8 (34.9)	1	3	62L
0.685	1 1/8 (34.9)	1 1/8 (34.9)	2	3	62L
0.935	1 1/8 (34.9)	1 1/8 (34.9)	2	1	92L
0.935	1 1/8 (34.9)	1 1/8 (34.9)	3	1	92L
0.935	1 1/8 (34.9)	1 1/8 (34.9)	1	3	92L
0.935	1 1/8 (34.9)	1 1/8 (34.9)	2	3	92L

Potting Cup for Right Angle Exit

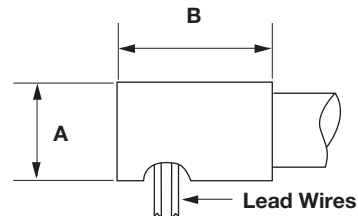

Heater O.D. in.	Dimension A in. (mm)	Dimension B in. (mm)	Zone	Phase	Type No.
0.685	3/4 (19)	1 1/2 (38)	1	1 or 3	RAE1
0.935	1 1/16 (27)	1 1/2 (38)	1	1 or 3	RAE2

Cartridge/Insertion Heaters

MULTICELL Heaters

Termination Assemblies

All termination assemblies are available with potting sleeves or cups, with or without armorflex lead wire protection. Please specify **potting vessel** and **lead cover option** when ordering.

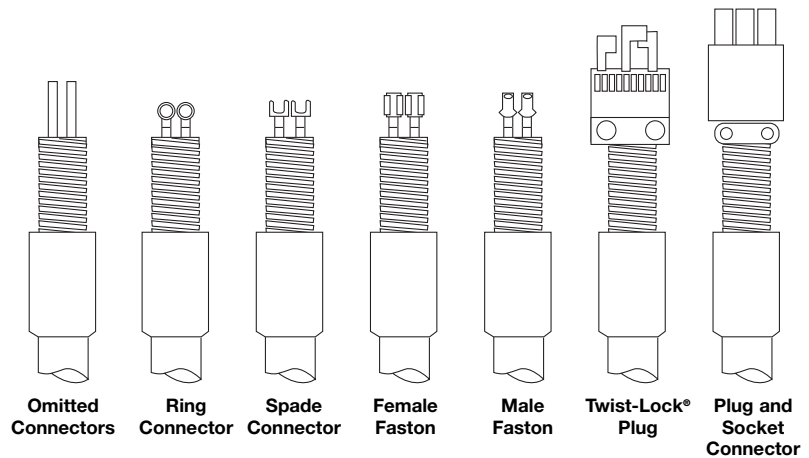

Termination illustrations shown with armorflex covering.

Options

Plug and Socket and Twist-Lock® Plug Variations

Three zone heaters requiring a quick disconnect plug will typically be supplied with a six contact plug and socket. Twist-Lock® plug variations are typically supplied with single zone MULTICELL heaters. When ordering a Twist-Lock® plug, please specify the **NEMA type** as shown below.

For any other plug variations, please contact your Watlow representative.

Note: Mating connectors are also available for plug terminations listed. Contact your Watlow representative.

Plug and Socket

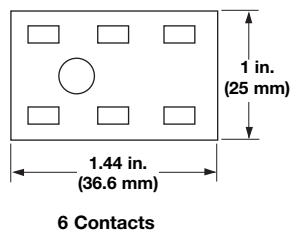

Male Plug	Zones	Type	Voltage	Amperage	Blade Type
P406-CCT	3	6 wire	600	30	Straight
4570C	1	3 wire	250	15	Twist-Lock®
4720C	1	3 wire	125	15	Twist-Lock®
5266C	1	3 wire	125	15	Straight
5666C	1	3 wire	250	15	Straight
7102C	1	2 wire	250	20	Twist-Lock®
7545C	1	2 wire	250	15	Twist-Lock®
7567C	1	3 wire	125	10	Twist-Lock®

Twist-Lock®

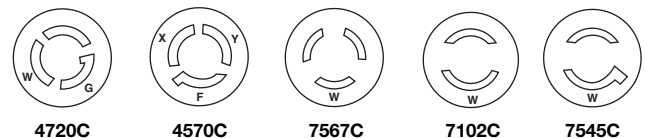

Straight

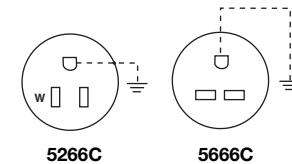

How to Order

To order MULTICELL insertion heaters, please specify:

- Sheath diameter
- Heater length
- Configuration
- Potting vessel
- Connector
- Lead cover
- Flexleads
- Watts
- Volts
- Lead wire length (12 in. [305 mm] standard)
- NEMA type for Twist-Lock®/straight plugs, if required
- Process temperature
- Controller system
- Ground voltage

Availability

Made-to-Order: Contact your Watlow representative.