



EM Gateway

User's Manual

For Watlow part number EM00-GATE-0000



1241 Bundy Boulevard, P.O. Box 5580, Winona, Minnesota USA 55987-5580
Phone: +1 (507) 454-5300, Fax: +1 (507) 452-4507, Internet: <http://www.watlow.com>

0600-0040-0001 Rev C
July 2002

\$10.00

EM Gateway

Table of Contents

Chapter 1:	Product Overview	3
	Ethernet Gateway	3
	Ethernet Gateway Architecture	3
	Program Upgrades	4
Chapter 2:	Installation and Wiring	5
	Dimensions	6
Chapter 3:	Configuration	7
	Getting Started	7
	Network Services	7
	Email Alarm Notification	7
	Data Logging	8
	Control Monitoring and Configuration	8
Chapter 4:	HTML Pages	9
	EM Gateway	9
	EM Gateway Setup	10
	EM Gateway Network Setup	11
	EM Gateway Email Setup	12
	EM Gateway Clock Setup	13
	EM Gateway Network Statistics	14
	EM Gateway Serial Statistics	15
Chapter 5:	Controller Parameters and Registers	16
	Series 96	16
	Series 97	16
	Series 981 / 982	16
	Series 988 / 989	17
	Series 998 / 999	17
	Series F4S / F4D	17
	Series F4P	18
	MicroDin	18
	Power Series	18
	CLS200 Series	19
Chapter 6:	Reference Documents	20
	Reference Documents	20
	Serial Numbers	20
Chapter 7:	Specifications	21
	Power Supply	21
	Environmental	21
	Indication	21
	Agency	21
	Communications	21
	Control Output Signals	21
	Enclosure Size	21
	User Interface	21
	Ordering Information	21
	How to Reach Us	23

Chapter One

Product Overview

The EM00-GATE-0000 is a gateway / bridge that allows up to 32 Watlow controllers to be directly connected to an Ethernet network. Using an HTTP Browser such as Microsoft Internet Explorer or Netscape Navigator you may access 16 controllers and view several controllers' parameters via an onboard Web (HTTP) server.

Ethernet Gateway

The Ethernet gateway provides a means for monitoring and configuring runtime parameters of multiple controllers via a web browser. The gateway is also a bridge for Modbus messages between the Ethernet bus and EIA-485 or EIA-232 links. The Gateway supports full product configuration; monitoring and configuration of runtime parameters via MODBUS TCP over TCP/IP using a software package such as Watview sold by Watlow.

Ethernet Gateway Architecture

This product has three physical connectivity points to the physical world. They are the serial (EIA-485 or EIA-232), Ethernet port (10BaseT), and the power supply pins.

The EIA-485 / EIA-232 connection supports Modbus RTU protocol and operates as a Master port. It will initiate data read/write requests to supported standard Watlow controllers. There exists a virtual image of the controller's data points in the gateway. The polling engine that initiates the Modbus RTU requests is responsible for synchronization of the virtual image and the actual controller. Changes to control data occur both at the controller and at the virtual image.

The 10BaseT connection supports the TCP/IP stack. At the application layer it has an HTTP (web) and Modbus server. The HTTP server will provide current controller status from the virtual image via HTML. The HTTP server provides a means of changing some runtime parameters via HTML. The TCP/IP stack supports DHCP client, AutoIP, static IP, DNS client, and Netbios name resolution. The 10BaseT connector is an RJ45 per the IEEE 802.3 specification.

The EM00-GATE-0000 can be used as a bridge for Modbus RTU messages. This is concurrent with all other communicating functions. In this scenario, the gateway simply passes the request that comes in on the Ethernet connection through to the EIA-485 or EIA-232 connection. When the response is returned from the controller, it is sent back on the Ethernet connection. No processing of the packet contents is necessary to bridge the two physical layers.

Block Diagram of Gateway

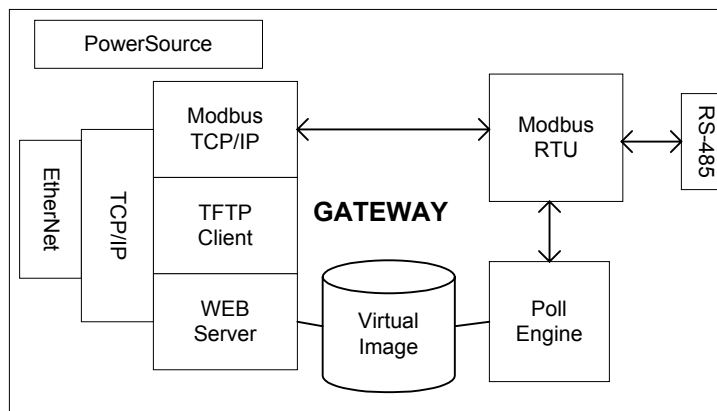

Program Upgrades

The gateway has a TFTP server for the purposes of reprogramming the program memory. A program update will be initiated when a TFTP client, residing on a PC, begins to write a new program file to the gateway TFTP server. When reprogramming the program memory, all other gateway services are unavailable.

The gateway provides no means of updating the program memory of controller devices, such as flashing new information into the Series F4.

Chapter Two

Installation & Wiring

EIA-485 Wiring

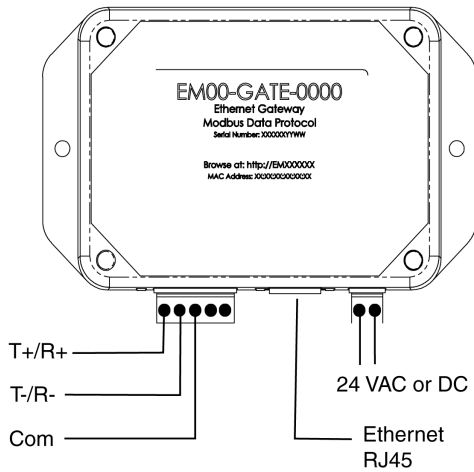

UL Approved, Class 2 power supply required

EIA-232 Wiring

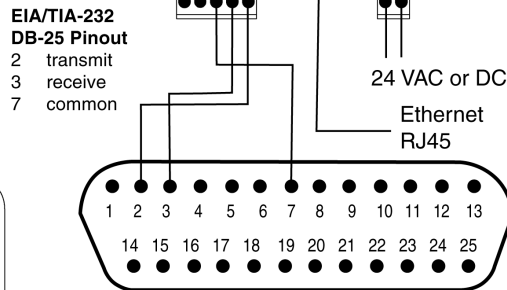
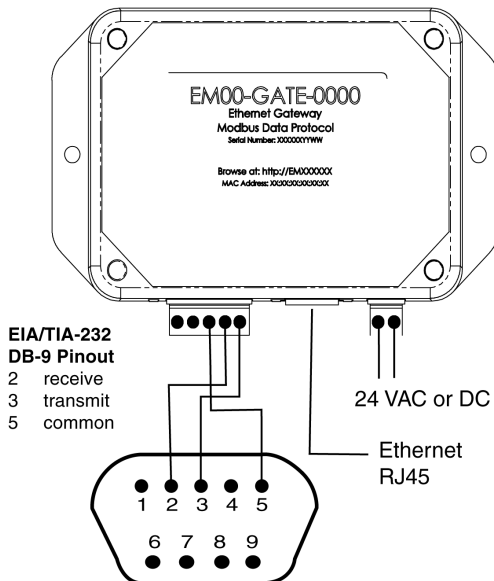

Note: The sub-D connectors are shown for convenience. Watlow controllers do not have sub-D connectors, rather have screw terminals. If you are not using sub-D connectors, wire directly to the appropriate terminals on the controllers.

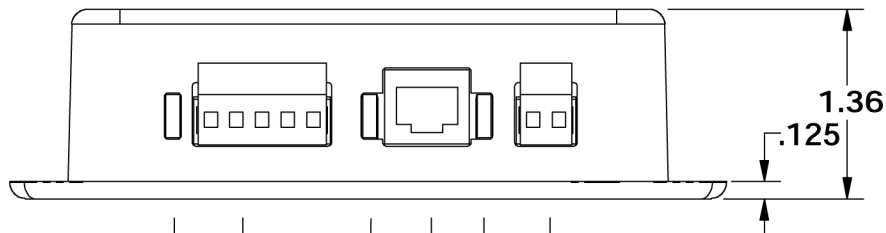
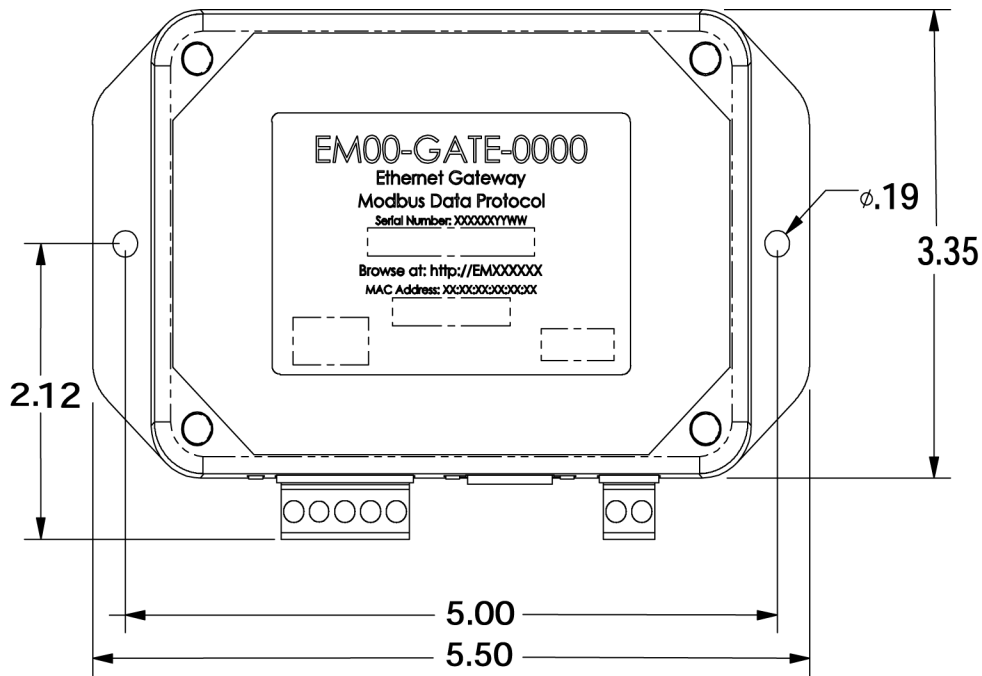

- | | | | | |
|---------------------------|---------|-----------------------------|-------------------------|------------------------|
| Device
Activity
LED | Pin | Ethernet
Activity
LED | Ethernet
RJ45 | 24 Volt Input
Power |
| | 1 T+/R+ | | | |
| | 2 T-/R- | | | |
| | 3 Com | | | |
| | 4 TXD | | Ethernet
Link
LED | |
| | 5 RXD | | | |

Dimensions are in inches

Chapter Three

Configuration

Getting Started

Perform these steps;

1. Connect the EM00-GATE-0000 gateway to your computer's Ethernet port using a cross-wired RJ45 cable or connect the EM00-GATE-0000 to a hub or network using a straight wired RJ45 Category 5 cable. The EM00-GATE-0000 is limited to a 10BaseT connection and will not work on an Ethernet port set for 100BaseT only. Use of a 10/100 hub will overcome this issue if your PC has only a 100BaseT port.
2. Wire the temperature controllers to the gateway's EIA-485 port. You may connect the gateway's EIA-232 port to a controller if you will be using only one controller, provided that the controller has an EIA-232 port.
3. Wire a 24-volt AC or DC power supply to the gateway terminals. This is not polarity sensitive.
4. Configure each controller to the same baud rate (9600 or 19200) from the front panel of the controller. Set each controller's Modbus address to a unique number. As an example, set the first controller to address 1, the second to address 2 and so on.
5. Power up the gateway, controllers and PC.
6. Start your Internet browser. Enter the TCP/IP address of the gateway into the browsers' address field. Two different addresses may be used to access the gateway. Either EMxxxxxx, where xxxxxx is the first six digits of the serial number, or WATxxxxxx, where xxxxxx is the last six digits of the gateways' MAC address. The MAC address is printed on a decal in the form xx:xx:xx:xx:xx:xx.
7. Select the Gateway Setup Page.
8. Configure the Baud Rate and range of controllers' addresses to match those you configured in step four.
9. Click on Rescan Modbus Network
10. Click on the back button of the browser to return to the previous page.
11. Click on the refresh button of the browser and your controllers' information should now be visible.

Note: You must click on the refresh button within the browser to capture the latest controller information. This information is automatically refreshed after 10 seconds by default. You may change this refresh time using the appropriate page.

Network Services

The EM00-GATE-0000 supports DHCP client, autoIP, and static IP for address assignment. Normally you will not need to make any changes. The user is able to configure preferences as to which services are used if available. Intelligence is employed within the gateway to revert to backup IP assignment methods if the primary method is unavailable.

The gateway does support DNS client and Netbios name resolution. Configuration information may be entered at the EM Gateway Network Display Setup page.

Email Alarm Notification

The email function allows the user to send emails to four addresses alerting them of alarm conditions that have occurred on the controllers connected to the Gateway. A button on the Graphical User Interface (GUI) allows the user to enable or disable this feature. Emails can be generated whenever an alarm condition occurs for each controller. An email acknowledge feature requires that the user acknowledge the email message by operating the email acknowledge button before additional email alarm messages can be generated for that controller. For multiloop controllers only one email acknowledge feature is supported; if more than one loop produces an alarm, only the first alarm detected will generate an email until acknowledged.

You will need to configure your Gateway with your SMTP server name or address. A DNS server address must also be configured if using a SMTP name. Contact your system administrator if you don't know the SMTP name or address.

Data Logging

The gateway provides no explicit means of data logging. Data can be polled via Modbus TCP by an external PC program. Consider WatView from Watlow for your setup, data logging and graphing needs.

Control Monitoring and Configuration

The gateway provides a means of monitoring the current process value for analog inputs of each controller using a built-in HTTP server. It also provides a means of monitoring the present alarm status of each controller. Additionally, you may monitor and change control set points for control loops of each controller.

The gateway is capable of supporting Watlow Series 96 non-ramping, 97, 981, 982, 988, 989, 998, 999, F4S, F4D, F4P, MicroDin, Power Series and CLS200 controllers with up to 16 controllers in any combination.

The gateway is capable of automatically determining when a controller is connected to the serial bus. It will identify the model and address of each controller. Controllers with duplicate Modbus addresses will be ignored by the gateway.

You can configure the baud rate of the EIA-485 or EIA-232 bus. You may also specify which controller addresses are scanned under the EM Gateway Setup page. The gateway supports from 1 to 16 controllers in any combination of supported model numbers. Select Rescan Modbus Network to update the detection of controllers on the bus. The Modbus network is automatically scanned every two minutes for new devices.

Chapter Four

HTML Pages

The section describes the pages available from the EM Gateway's Web server.

Device	Modbus Address	A/M Mode	Input No.	Input Error	Process Value	Auto Setpoint	Alarm Status	Alarm Ack	Email Ack
F4	1	Auto	1)	Ok	100	120	Alarm 1 Ok		
			2)	Ok	135	136			
Series 982	2	Hold	1)	Ok	78	78	Alarm 2 Ok		
			2)	Ok			Alarm 3 Ok		

This is the main page for monitoring the controllers on the Gateway. You can click on values that are located within a box. Entering in a new value may change these values. In addition, use Alarm Ack to clear alarms when a process value has returned within a safe operating range. Use the Email Ack to reactivate future emails for this controller. See the controller's user's manuals for details of Modes, Errors, and Alarm operation.

This page was loaded Thu Feb 14 13:37:08 2002

Display Setup

Enable "Home" page auto-refresh interval.

Time period of "Home" page auto refresh (5-9999 seconds).

Modbus

Note: Submitting any changes to the Modbus settings below will cause the EM Gateway to rediscover any serial devices.

[Rescan Modbus Network](#)

Baud Rate:

Start Address: 1-247

End Address: 1-247

Maximum Nodes: 1-16

Ethernet

[Network Setup](#)

[Email Setup](#)

[Clock Setup](#)

[Network Statistics](#)

[Serial Statistics](#)

Use this page to disable or enable automatic page refreshing or to change the time in between refreshes.

In addition, you can force a rescan of the Modbus Network. This will cause the Gateway to detect any new devices added to the serial network. Set the baud rate of the network to 9600 or 19200-baud. The value selected must match the value in all of the controllers on the serial network. Up to 16 controllers may be scanned by the Gateway using the built-in HTTP server. Set a start address to the lowest address number of the controller on the serial network. Set an end address to the highest address number of the controller on the serial network.

As an example, you have your first controller set to address 23 and the last one set to 35. Set Start Address to 23 and End Address to 35. You can limit the number of controllers accessed by the Gateway by setting the Maximum Nodes value to less than 16.

Lastly, this page provides links to Network Setup, Email Setup, Clock Setup, Network Statistics, and the Serial Statistics pages.

This page was loaded Thu Feb 14 13:37:30 2002

Device Identification

Name

Current Settings

IP Address 7.3.37.91
Subnet Mask 255.255.224.0
Default Gateway 7.3.63.250
DNS Server 7.3.55.4

IP Address Resolution Method

Choose the method for this hosts IP address assignment.

- Try DHCP server, then use Auto IP, then use fixed IP address
- Try DHCP server, then use fixed IP address
- Try Auto IP, then use fixed IP address
- Use Fixed IP address

Fixed IP Address

Fixed IP Address
Fixed Subnet Mask
Fixed Gateway
Fixed DNS Server

Use this page to change the Gateway identification name or to change the IP Address Resolution Method. Contact your IS administrator for questions regarding these settings.

This page was loaded Thu Feb 14 13:37:49 2002

Electronic Notification

The SMTP Server Address has priority over the SMTP Server Name.
To use the SMTP Server Name, leave the SMTP Server Address blank.
The SMTP Server Name requires a DNS look-up.
Alarms that occur before the Server Name is resolved are not sent.

Enable Email Notification

SMTP Server Name	<input type="text"/>	Example: smtp.company.com
SMTP Server Address	<input type="text"/>	Example: 102.43.23.2
Email Subject	<input type="text"/>	Example: EM Gateway Alert
Source Email Address	<input type="text"/>	Example: joe_service@company.com
Email Recipient 1	<input type="text"/>	Example: 3125554444@pager.com
Email Recipient 2	<input type="text"/>	Example: anyone@yahoo.com
Email Recipient 3	<input type="text"/>	Leave blank if unused
Email Recipient 4	<input type="text"/>	Leave blank if unused

Location Info Appended to Email

Use this page to enable or disable email notification and configure the addresses for email recipients. These recipients will receive an email when an alarm occurs on any controller. Contact your IS administrator for questions regarding these settings.



EM Gateway Clock Setup

This page was loaded Thu Feb 14 13:38:06 2002

Current EM Gateway Time: 14-Feb-2002 13:35:42

Year	<input type="text" value="2002"/>
Month	<input type="text" value="Feb"/>
Date	<input type="text" value="14"/>
Hour	<input type="text" value="13"/>
Minute	<input type="text" value="35"/>
Second	<input type="text" value="42"/>

<input type="button" value="Submit"/>	<input type="button" value="Reset"/>
---------------------------------------	--------------------------------------

Use this page to update the time and date stored in the Gateway. This information is used to identify the time and date of alarms when emails are sent.



EM Gateway Serial Stats

This page was loaded Thu Feb 14 13:38:53 2002

Device Address	Timeout Errors	Retry Errors	CRC Errors	Bad Polls	Good Polls	Illness
1	0	0	0	0	1174	0
2	0	0	0	0	1174	0
3	0	0	0	0	1174	0
4	0	0	0	0	1174	0
5	0	0	0	0	1174	0
6	0	0	0	0	1174	0
7	0	0	0	0	1174	0
8	0	0	0	0	1174	0
9	0	0	0	0	1174	0
10	0	0	0	0	1174	0
11	5	2	0	3	1167	0
12	0	0	0	0	1174	0
13	0	0	0	0	1174	0
14	0	0	0	0	1174	0
15	0	0	0	0	1174	0
16	0	0	0	0	1174	0

The Serial Statistic page is used to monitor the health of the controller network. These numbers will help identify when there are issues with wiring, duplicate Modbus ID addresses or noise on communication wires on the controller side of the network. In this example, controller number 11 is experiencing failure in communication quality.

Timeout Errors increments anytime that a controller does not respond in an appropriate amount of time.

Retry Errors increments anytime that a controller does not respond after 3 attempts to read information.

CRC Errors increments anytime that the controller responds with a bad packet.

Bad Polls increments when there are timeouts and the retries did not successfully retrieve information.

Good Polls increments on each valid packet received.

Illness increments anytime that there are 5 CRC or Timeout errors in a row. After a count of 5 in the Illness column, the controller is flagged as having no communication. On the next valid packet received, the Illness value is cleared to zero and communications is restored.

You must refresh the browser to see these numbers update.



This page was loaded Wed Feb 13 18: 00:28 2002

IP Address	7.3.37.91
Subnet	255.255.224.0
Gateway	7.3.63.250
Mac Address	00:03:AA:00:00:C1
Receives	128349
Unicasts	1207
Multicasts	0
Broadcasts	127061
Rx Errors	0
Rx Missed	2089
Rx CRC Errors	28
Rx Drops	0
Transmits	1251
Buffer Defers	0
Tx Errors	0
Tx Collisions	0
Tx Coll. Overflow	0
Tx FILO Errors	0
Traffic Backoffs	0
Network Rejects	84154
Address Rejects	25
Protocol Rejects	10492
ARP Rejects	19361
SMTP Server IP	0.0.0.0
Send Queue Length	0
Send Queue Max	1
Send Queue Min	0
Recv Queue Length	0
Recv Queue Max	7
Recv Queue Min	0
Big Queue Length	28
Big Queue Max	30
Big Queue Min	26
Little Queue Length	28
Little Queue Max	30
Little Queue Min	2

The Network Statistics page monitors the health of the Ethernet network. These numbers will help identify settings for the EM Gateway as well as when there are issues with wiring, incorrect addresses or noise on communication wires on the Ethernet side of the Gateway.

Chapter Five

Controller Parameters and Registers

The EM Gateway supports the following parameters for each type of controller when using an HTTP browser:

Series 96 – non-ramping

Operation Mode – register 200 with choices of Auto or Manual as read only

Input Error – register 101 with choices of Sensor Error or Ok as read only

Process Value Input 1 – register 100 as read only

Process Value Input 2 – register 105 as read only

Auto Set Point 1 – register 300 as read/write

Alarm Status Output 2 – register 106 with choices of Ok, Alarm High, Alarm Low, Alarm High Latched, Alarm Low Latched, Alarm High Silenced, Alarm Low Silenced, Alarm High Latched Silenced, Alarm Low Latched Silenced, Waiting for in Range Alarm, Alarm Disabled, or Alarm Error as read only

Alarm Status Output 3 – register 106 with choices of Ok, Alarm High, Alarm Low, Alarm High Latched, Alarm Low Latched, Alarm High Silenced, Alarm Low Silenced, Alarm High Latched Silenced, Alarm Low Latched Silenced, Waiting for in Range Alarm, Alarm Disabled, or Alarm Error as read only

Alarm Acknowledge – register 331 with choice to clear alarm as write only

Note: Selecting Manual control using the Operation Mode, an input error or inputting a Set Point value less than –30000 will disable the Auto Set Point. Alarms not configured are not displayed. Alarms can not be acknowledged while the alarm condition exists.

Series 97

Process Value Input 1 – register 100 as read only

Limit Status – register 319 with choices of Ok, High Limit, Low Limit, or Limit Error as read only

Alarm Status Output 2 – register 106 with choices of Ok, Alarm High, Alarm Low or Alarm Error as read only

Alarm Status Output 3 – register 110 with choices of Ok, Alarm High, Alarm Low, or Alarm Error as read only

Alarm Acknowledge – register 331 with choice to clear alarm as write only

Note: Alarms configured are displayed. Alarms can not be acknowledged while the alarm condition exists.

Series 981 / 982

Operation Mode – register 200 with choices of Hold, Run, or Pre-run as read only

Input Error – register 209 with choices of Sensor Error or Ok as read only

Process Value Input 1 – register 100 as read only

Auto Set Point – register 300 as read/write

Alarm Status Output 2 – register 106 with choices of Ok, Alarm High, Alarm Low or Alarm Error as read only

Alarm Status Output 3 – register 110 with choices of Ok, Alarm High, Alarm Low, or Alarm Error as read only

Alarm Acknowledge – register 106 with choice to clear alarm as write only

Note: An input error or inputting Set Point values less than –30000 will disable the Auto Set Point. Alarms not configured are not displayed. Alarms can not be acknowledged while the alarm condition exists.

Series 988 / 989

Operation Mode – register 10 with choices of Auto or Manual as read only

Input Error – register 4 with choices of Sensor Error or Ok as read only

Process Value Input 1 – register 1 as read only

Process Value Input 2 – register 2 as read only

Auto Set Point – register 7 as read/write

Alarm Status Output 2/3 – register 3 with choices of Ok, Alarm High, Alarm Low or Alarm Error as read only

Alarm Acknowledge – register 3 with choice to clear alarm as write only

Note: Selecting Manual control using the Operation Mode, an input error or inputting Set Point values less than –30000 will disable the Auto Set Point. Alarms not configured are not displayed. Alarms can not be acknowledged while the alarm condition exists.

Series 998 / 999

Operation Mode – register 301 with choices of Auto or Manual as read only

Input Error – register 209 with choices of Sensor Error or Ok as read only

Process Value Input 1 – register 100 as read only

Process Value Input 2 – register 104 as read only

Auto Set Point 1 – register 300 as read/write

Auto Set Point 2 – register 319 as read/write

Alarm Status Output 3 – register 110 with choices of Ok, Alarm High, Alarm Low, or Alarm Error as read only

Alarm Acknowledge – register 110 with choice to clear alarm as write only

Note: Selecting Manual control using the Operation Mode, an input error or inputting Set Point values less than –30000 will disable Auto Set Points 1 or 2. Alarms not configured are not displayed. Alarms can not be acknowledged while the alarm condition exists.

Series F4S / F4D

Operation Mode – register 200 with choices of Auto or Manual as read only

Input 1 Error – register 101 with choices of Sensor Error or Ok as read only

Input 2 Error – register 105 with choices of Sensor Error or Ok as read only

Input 3 Error – register 109 with choices of Sensor Error or Ok as read only

Process Value Input 1 – register 100 as read only

Process Value Input 2 – register 104 as read only

Process Value Input 3 – register 108 as read only

Auto Set Point 1 – register 300 as read/write

Auto Set Point 2 – register 319 as read/write

Alarm Status Output 2 – register 102 with choices of Ok, Alarm High, Alarm Low, Alarm High Latched, Alarm Low Latched, Alarm High Silenced, Alarm Low Silenced, Alarm High Latched Silenced, Alarm Low Latched Silenced, Waiting for in Range Alarm, Alarm Disabled, or Alarm Error as read only

Alarm Status Output 3 – register 106 with choices of Ok, Alarm High, Alarm Low, Alarm High Latched, Alarm Low Latched, Alarm High Silenced, Alarm Low Silenced, Alarm High Latched Silenced, Alarm Low Latched Silenced, Waiting for in Range Alarm, Alarm Disabled, or Alarm Error as read only

Alarm 1 Acknowledge – register 312 with choice to clear alarm as write only

Alarm 2 Acknowledge – register 331 with choice to clear alarm as write only

Note: Alarms configured are displayed. Alarms can not be acknowledged when the alarm condition still exists.

Series F4P

Operation Mode – register 200 with choices of Auto or Manual as read only

Input 1 Error – register 101 with choices of Sensor Error or Ok as read only

Input 2 Error – register 105 with choices of Sensor Error or Ok as read only

Input 3 Error – register 109 with choices of Sensor Error or Ok as read only

Process Value Input 1 – register 100 as read only

Process Value Input 2 – register 104 as read only

Process Value Input 3 – register 108 as read only

Auto Set Point – register 300 as read/write

Alarm Status Output 2 – register 102 with choices of Ok, Alarm High, Alarm Low, Alarm High Latched, Alarm Low Latched, Alarm High Silenced, Alarm Low Silenced, Alarm High Latched Silenced, Alarm Low Latched Silenced, Waiting for in Range Alarm, Alarm Disabled, or Alarm Error as read only

Alarm Status Output 3 – register 106 with choices of Ok, Alarm High, Alarm Low, Alarm High Latched, Alarm Low Latched, Alarm High Silenced, Alarm Low Silenced, Alarm High Latched Silenced, Alarm Low Latched Silenced, Waiting for in Range Alarm, Alarm Disabled, or Alarm Error as read only

Alarm 1 Acknowledge – register 312 with choice to clear alarm as write only

Alarm 2 Acknowledge – register 331 with choice to clear alarm as write only

Note: Alarms configured are displayed. Alarms can not be acknowledged when the alarm condition still exists.

MicroDIN

Operation Mode – register 200 with choices of Auto or Manual as read only

Input Error – register 101 with choices of Sensor Error or Ok as read only

Process Value Input 1 – register 100 as read only

Auto Set Point – register 300 as read/write

Alarm Status Output 2 – register 106 with choices of Ok, Alarm High, Alarm Low, Alarm High Latched, Alarm Low Latched, Alarm High Silenced, Alarm Low Silenced, Alarm High Latched Silenced, Alarm Low Latched Silenced, Waiting for in Range Alarm, Alarm Disabled, or Alarm Error as read only

Alarm Acknowledge – register 331 with choice to clear alarm as write only

Note: Alarms configured are displayed. Alarms can not be acknowledged when the alarm condition still exists.

Power Series

Heat Sink Temperature in Degrees C - register 1590 as read only

Load Current in Amps RMS on Line 1 - register 154 as read only (Based on configuration)

Load Current in Amps RMS on Line 2 - register 164 as read only (Based on configuration)

Load Current in Amps RMS on Line 3 - register 174 as read only (Based on configuration)

Note: Display of current on lines 1, 2, and 3 depends on the number of zones, the installed options and the load type.

CLS200 Series (Loop 1 to 16 if available)

Operation Mode – register 264 to 279 with choices of Auto or Manual as read only

Input Error – registers 660 to 675 with choices of Ok, TC Reversed, TC Short, TC Open, RTD Open, or RTD Short as read only

Process Value – registers 363 to 378 as read only

Auto Set Point – registers 330 to 345 as read/write

Alarm Status – registers 660 to 675 with choices of Ok, Low Deviation, High Deviation, Low Process, or High Process as read only

Alarm Acknowledge – registers 8311 to 8326 with choice to clear alarm as write only

Note: Alarms configured are displayed. Alarms can not be acknowledged when the alarm condition still exists.

Note: The Communication Specifications manual list absolute registers, which are the relative register with 40001 added to them. As an example, relative register 264 is absolute register 40265.

Chapter Six

Reference Documents

MODBUS RTU Standard located at: <http://www.modicon.com/techpubs/toc7.html>.

Serial Numbers

Gateways are labeled with a unique serial number in numeric and bar code formats. The serial number is embedded in the gateway firmware.

EM Gateway Features and Benefits

- Ethernet/Internet connectivity
Operate & monitor your process remotely.
- Browser Graphical User Interface (GUI)
Operate & monitor your process remotely with standard Web browsers.
- Dedicated Web page design
Easy to understand and operate
- Email alarm notification
Reduced process monitoring costs

Chapter Seven

Specifications

Power supply

- Voltage input 24 V (ac/dc) +10%, -15% 50/60 Hz +/- 5
- Connection through 2-position removable screw style terminal block
 - 22 to 12 AWG
- Power consumption 10 VA MAX
 - UL Approved, Class 2 power supply required
- Real-time Clock backed by 3v-lithium battery – RAYOVAC BR1225

Environmental

- Operating temperature range: 0 to 60°C
- Storage temperature range: -40 to 70°C
- Operating and storage humidity: 0 to 90% non-condensing

Indication

- Green LED for Ethernet connection
- Green LED for Ethernet activity
- Green LED for EIA-485 or EIA-232 activity

Agency

- CE Approved, see Declaration of Conformity 61326 Industrial Immunity, Class B Emissions

Communications

- MODBUS RTU communications
 - Both EIA-485 and EIA-232 supported at 9600 and 19200 baud
 - Connection through 5-position removable screw style terminal block
 - 22 to 12 AWG
- Ethernet communications
 - Ethernet RJ45 Connector
 - 10BaseT per IEEE 802.3 Ethernet Standard
 - HTTP v1.1
 - Modbus TCP
 - DHCP, Auto IP, Or Fixed IP Address
 - Email Alarm Notification
- Supports Windows browsers
 - Microsoft Internet Explorer 4.0 or newer
 - Netscape 4.0 or newer

Control Output Signals

Activity L.E.D. for Ethernet communications per IEEE 802.3

Activity L.E.D. for Serial communications.

Enclosure Size

Dimensional Size - L: 3.75 in X W: 1 in X H: 2.5 in, with cutouts for L.E.D.'s, RJ45 port and power jack.

User Interface

3 L.E.D.s to indicate operation status; Ethernet link, Ethernet traffic and Modbus traffic.

Ordering Information

Order part number EM00-GATE-0000

Declaration of Conformity

Gateway Products



Watlow Winona, Inc.
1241 Bundy Blvd.
Winona, MN 55987 USA

Declares that the following product:

Model Numbers:	EM00-GATE-0000, NGW0-0000-2400 and NGW0-0000-0000*
Classification:	Communications interface card, Installation Category I, Pollution degree II
Rated Voltage:	24V (ac or dc) or 5V (dc)
Rated Frequency:	50/60 Hz or dc
Rated Power:	10VA maximum

*NGW0-0000-0000 Requires use of a Ferrico NF130 Clamp on ferrite on all lines to pass Class B emissions. Depending on end use setup, this bead may or may not be necessary.

Meets the essential requirements of the following European Union Directives by using the relevant standards show below to indicate compliance.

89/336/EEC Electromagnetic Compatibility Directive

EN 61326:1997 With A1:1998 – Electrical equipment for measurement, control and laboratory use – EMC requirements (Industrial Immunity, Class B Emissions).

EN 61000-4-2:1996 With A1, 1998 – Electrostatic Discharge Immunity
EN 61000-4-3:1997 – Radiated Field Immunity
EN 61000-4-4:1995 – Electrical Fast-Transient / Burst Immunity
EN 61000-4-5:1995 With A1, 1996 – Surge Immunity
EN 61000-4-6:1996 – Conducted Immunity
EN 61000-4-11:1994 Voltage Dips, Short Interruptions and Voltage Variations Immunity
EN 61000-3-2:1995 With A1-3:1999 – Harmonic Current Emissions
EN 61000-3-3:1995 With A1:1998 – Voltage Fluctuations and Flicker

Use of an appropriately approved class 2 power source is required for compliance.

Jim Boigenzahn
Name of Authorized Representative

Winona, Minnesota, USA
Place of Issue

General Manager
Title of Authorized Representative

February 28, 2002
Date of Issue

Signature of Authorized Representative

How to Reach Us

Technical Assistance

If you encounter a problem with your EM Gateway, review all of your wiring and configuration information to verify that your selections are consistent with your application. If the problem persists after checking the above, you can get technical assistance from your local Watlow representative, or by dialing (507) 454-5300. An applications engineer will discuss your application with you.

Warranty

This product is warranted free from defects in material and workmanship for 36 months after delivery to the first purchaser for use, providing that the units have not been misapplied. Since Watlow has no control over their use, and sometimes misuse, we cannot guarantee against failure. Watlow's obligations hereunder, at Watlow's option, are limited to replacement, repair or refund of purchase price, and parts that upon examination prove to be defective within the warranty period specified. This warranty does not apply to damage resulting from transportation, alteration, misuse or abuse.

Returns

- Call or fax Customer Service for a Return Material Authorization (RMA) number before returning any product.
- Put the RMA number on the shipping label, and provide a written description of the problem.
- A restocking charge of 20% of the net price is charged for all standard units returned to stock.

Your Feedback

Your comments or suggestions on this manual are welcome, please send them to: Technical Writer, Watlow Winona, 1241 Bundy Blvd., P.O. Box 5580, Winona, MN 55987-5580, Phone: (507) 454-5300, Fax: (507) 452-4507. Watlow Winona, Inc., ©, copyrights the EM User's Manual February 2002, with all rights reserved. (2297)