

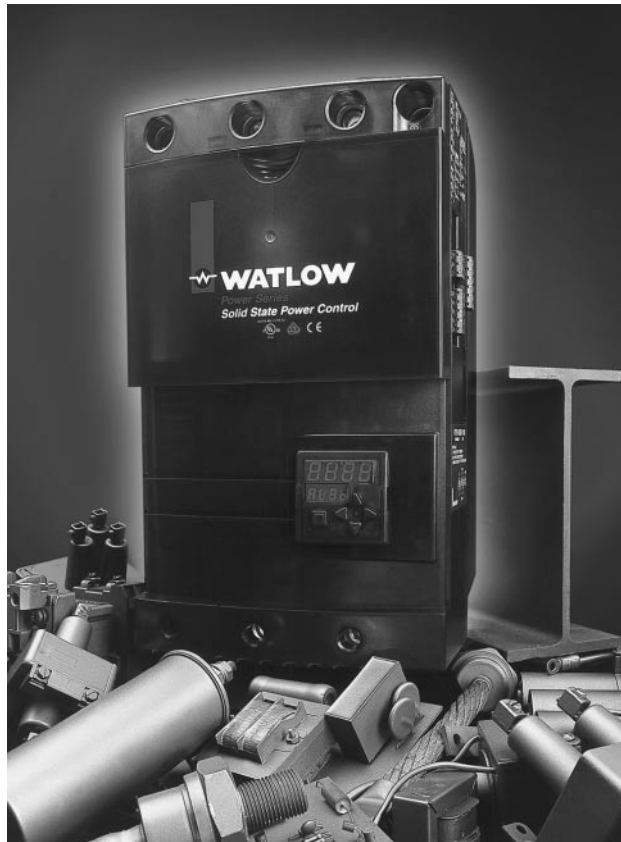

Power Series User's Manual



Microprocessor-Based SCR Power Controller



U.S. English

1241 Bundy Boulevard, P.O. Box 5580, Winona, Minnesota USA 55987-5580
Phone: +1 (507) 454-5300, Fax: +1 (507) 452-4507 <http://www.watlow.com>

0600-0039-0000 Rev C
March 2002
Supersedes: 0600-0039-0000 Rev B

Made in the U.S.A.
\$10.00



Safety Alert
CAUTION or
WARNING



Electrical
Shock Hazard
CAUTION or
WARNING

Safety Information in this Manual

Note, caution and warning symbols appear throughout this book to draw your attention to important operational and safety information.

A “NOTE” marks a short message to alert you to an important detail.

A “CAUTION” safety alert appears with information that is important for protecting your equipment and performance.

A “WARNING” safety alert appears with information that is important for protecting you, others and equipment from damage. Pay very close attention to all warnings that apply to your application.

The ⚠ symbol (an exclamation point in a triangle) precedes a general CAUTION or WARNING statement.

The ⚡ symbol (a lightning bolt in a lightning bolt in a triangle) precedes an electric shock hazard CAUTION or WARNING safety statement.

Technical Assistance

If you encounter a problem with your Watlow controller, see the Troubleshooting Table in the Appendix and review all of your configuration information to verify that your selections are consistent with your application: inputs; outputs; alarms; limits; etc. If the problem persists after checking the above, you can get technical assistance from your local Watlow representative, or by dialing +1 (507) 454-5300, 7:00 a.m. to 7:00 p.m. Central Standard Time.

An applications engineer will discuss your application with you.

Please have the following information available when you call:

- Complete model number
- All configuration information
- User’s Manual
- Diagnostic Menu readings

Warranty and return information are on the back cover of this manual.

Your Comments

Your comments or suggestions on this manual are welcome. Please send them to the Technical Literature Team, Watlow Winona, 1241 Bundy Boulevard, P.O. Box 5580, Winona, Minnesota, 55987-5580 U.S.; Telephone: +1 (507) 454-5300; fax: +1 (507) 452-4507. The Power Series User’s Manual is copyrighted by Watlow Winona, Inc., © 2002, with all rights reserved. (2211)

T

Power Series Table of Contents

Chapter 1: Overview	1.1	Appendix	A.1
Chapter 2: Installation	2.1	Troubleshooting	A.2
Dimensions	2.2	Troubleshooting Alarms and Errors	A.4
Mounting the Power Series	2.2	Checking and Replacing Fuses	A.6
Enclosure Guidelines	2.3	Power Series Backup	A.7
Harsh Environments	2.3	Modbus™ Register Numbers	A.8
Removing the Power Series	2.4	Product Specifications	A.9
Maintaining the Power Series	2.4	Ordering Information	A.10
Output Rating Curves	2.5	Index	A.11
Chapter 3: Wiring	3.1	Prompt Index	A.13
Torque Guidelines	3.1	CE Declaration of Conformity	A.14
Input Wiring	3.2	Warranty and Returns Policy	back cover
Line Power/Output Wiring	3.4		
Wiring Example	3.6		
Chapter 4: Navigation and Software	4.1		
Keys and Displays	4.1		
Navigation	4.2		
Software Map	4.3		
Chapter 5: Control Methods and Features	5.1		
Zero Cross	5.1		
Phase Angle	5.2		
Other Features	5.6		
Input	5.6		
Alarms	5.7		
Communications	5.8		
Retransmit	5.9		
Fast Start Guide	5.10		
Chapter 6: Parameters	6.1		
Display Loop	6.1		
Setup Page	6.5		
Factory Page	6.14		
Factory Mode	6.20		

1

Chapter One Overview

Introduction

The Power Series is a state-of-the-art microprocessor-based Silicon Controlled Rectifier (SCR) power controller intended for controlling industrial heaters. This product is based on one package with several configurations that include single phase, three phase, and single phase-multizone capabilities. Each package configuration has a specific current rating depending on the number of phases switched. The switching capabilities include 65 to 250A rms at 50°C from 24 to 600V~ depending on the configuration or model number selected. See page 1.2 for additional information on the Power Series configuration options.

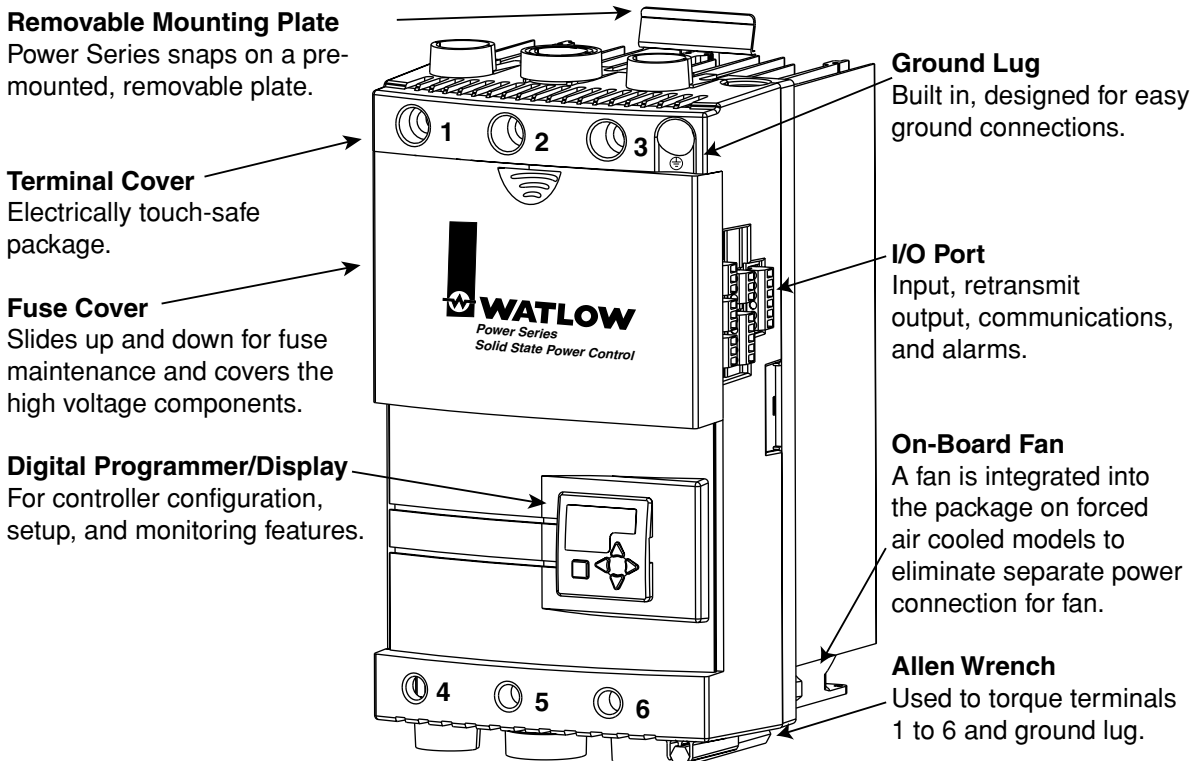

Figure 1.1 — Power Series features.

Single Phase

This configuration can be purchased with any or all the features available on the Power Series. The only limitations are the features selected by the customer upon purchase. It has the highest current rating of all configurations since it is only switching one phase of the ac line. It is intended for resistive heaters, but can also be used on transformer connected loads in the phase angle firing mode.

Three Phase, Two-Leg Configuration

This configuration is intended for zero cross firing into a stable resistive heater, i.e., nichrome element. Typically, a three phase, three-wire delta or ungrounded wye/star connected heater is most often used where only two of the three V~ line phases are switched. The third phase is a direct connection through a bussbar on board the Power Series and is controlled by the previous two phases. For this reason, a two-leg configuration should not be used for three phase grounded wye/star connected heaters. (For heaters that are required to be three phase grounded wye/star connected, see “Three Phase, Three-Leg Configuration” section below.)

Because this configuration does not allow phase angle firing, it should not be used on transformer coupled heaters and less stable resistance heaters such as silicon carbide, molybdenum disilicide, carbon graphite, or tungsten lamp heaters. This may cause premature heater failure or nuisance fuse blowing.

Heater current monitoring and kVA options are available with a three phase, two-leg configuration via the heater diagnostics option. Phase angle firing, including current limiting and heater bakeout, is not available.

Three Phase, Three-Leg Configuration

There are two Power Series configurations that include six SCR control. All features are available in these configurations.

The three-leg version is intended for phase angle firing into a transformer connected load or direct connection to heating that requires soft start and/or current limiting.

The four-wire configuration is intended for zero cross firing into a four-wire wye connected nichrome/resistive heater.

Single Phase, Multizone Configuration

This configuration is available in two and three single phase zones. Back-to-back SCRs are used and all of the features of a single phase unit are available. (Note that there is only one alarm relay and all zones in the controller must use the same control method.) This configuration is intended for applications with multiple command signals from independent control zones. The multizone platform offers reduced panel space compared to using multiple single phase power controllers.

Heater Diagnostics

Heater diagnostics is a key feature of the Power Series SCR power controller. Heater diagnostics may include all or only some of the features that require heater current monitoring, depending on the model selected. Heater current monitoring is only available with heater diagnostics installed on the controller. The features dependent on heater current monitoring are heater bakeout, current limiting, heater current and kVA monitoring, retransmit, and heater monitoring alarms such as open heater, heater out of tolerance, load balance, and shorted SCR detection/error. Heater diagnostics must also be installed if you need phase angle control with current limit.

2

Chapter Two Installation

The following two chapters will explain how to install the Power Series controller. Watlow power controllers are thoroughly tested before leaving the factory, so the Power Series controller is ready to install when you receive it.

Chapters 2 and 3 describe the steps required to install the Power Series controller. Refer to Chapter 2 for mounting information and Chapter 3 for input, power, and load wiring of the Power Series.

Before beginning installation, read through these chapters to gain an understanding of the entire installation. Consider the installation carefully. Plan the power, load, and input signal wiring before mounting the Power Series. Also consider the cabinet space, controller dimensions, wire bending radius, and airflow. Use good wiring practices to minimize electrical noise problems.



WARNING:

To avoid potential electric shock and other hazards, all mounting and wiring for the Power Series must conform to the National Electric Code (NEC) and other locally applicable codes.

NOTE: Ground must be wired with the same size wire as line and load connections to a ground of sufficient current carrying capacity.

NOTE: Integral semiconductor fuses do not qualify as branch circuit protection.

Power Series Wire Bending Radius at Base Current and Ambient Temperature Rating

Minimum recommended wire sizes are based on the NEC 30°C ambient with not more than three current carrying conductors in raceway or cable, while also considering the Power Series 50°C enclosure temperature and semiconductor fuse rating. Use copper conductors only.

The terminal lug wire range for all Power Series amperages is 350 MCM to 6 AWG. The recommended terminal torque is 180 in.-lbs. (20 Nm.). Refer to page 3.1 for torque guidelines.

Power Series Current (Amps)	Semi-conductor Fuse Rating (Amps)	Minimum Recommended Wire Size (90°C) (AWG)	Wire Bending Radius	
			(mm)	(inches)
65	100	6	51	2.0
80	125	4	76	3.0
85	125	4	76	3.0
90	125	4	76	3.0
100	160	3	76	3.0
105	160	3	76	3.0
120	160	2	89	3.5
125	160	2	89	3.5
140	200	1	114	4.5
155	200	1/0	140	5.5
160	250	1/0	140	5.5
165	250	1/0	140	5.5
185	250	2/0	152	6.0
200	250	3/0	165	6.5
250	315	4/0	178	7.0

Power Series Dimensions

Power Series Top View

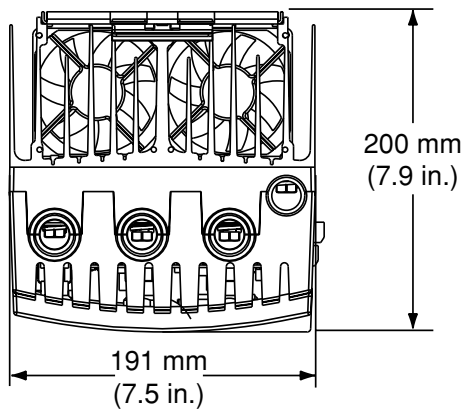

Power Series Front View

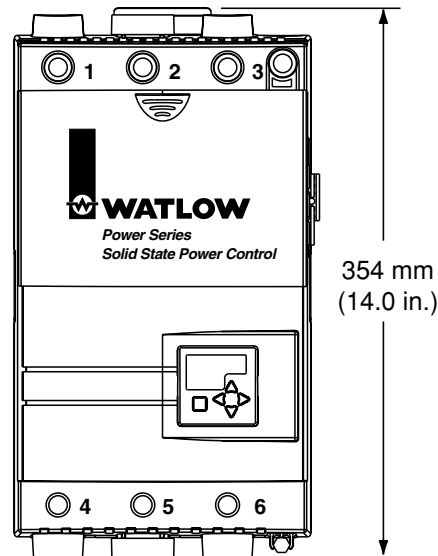

Figure 2.2a — Power Series dimensions.

Mounting the Power Series Controller

NOTE: The Power Series controller must be mounted vertically. When multiple units are used in one cabinet, it is best that they are mounted side-by-side when possible. If they are mounted one above the other, adequate spacing and airflow must be provided. See Enclosure Guidelines on page 2.3.

1. Determine the panel location for mounting the Power Series controller and punch or drill holes for the 4 mounting screws per the drawing below. The mounting plate can be used as a template.
2. Attach the Power Series mounting plate using 4 screws (customer supplied, #10 screw minimum, 1/4 inch screw maximum).
3. Align the heads of the shoulder screws on the back of the Power Series heat sink with the key slots on the mounting plate. Push the unit in, and then down until it snaps into place. Mounting is complete.

Power Series Mounting Plate

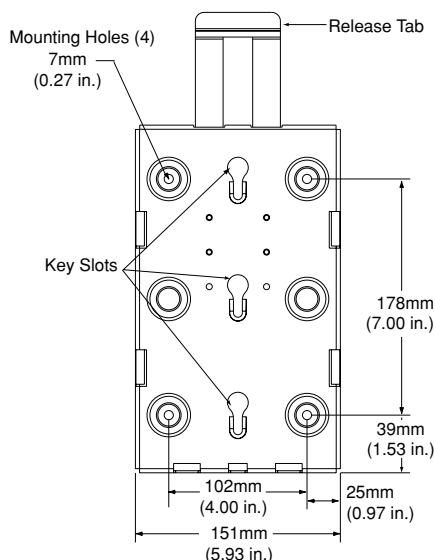

Figure 2.2b — Mounting plate dimensions.

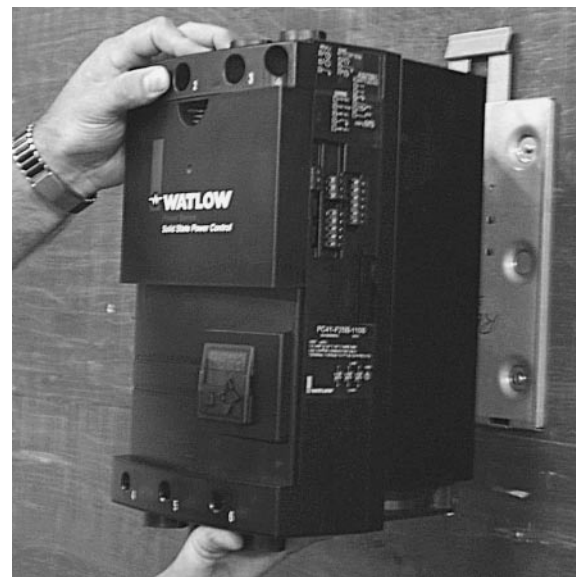

Figure 2.2c — Installing the controller.

Enclosure Guidelines

The Power Series must be mounted in a suitable electrical enclosure. It must have adequate wire bending space and cooling. The maximum ambient temperature in the enclosure must not exceed 50°C (122°F) for name plate rating. For other output ratings and enclosure ambient temperatures, see output rating curves on pages 2.5 and 2.6.

To maintain the proper cooling, the enclosure must be large enough to dissipate the heat generated by the Power Series, or there must be some form of active cooling.

1. Air circulation — fans bring air into the bottom of the enclosure and louver plates to allow the air to exit the top of the enclosure. Filters are not recommended as they can become plugged and block air flow. To maintain 80 percent of the CFM of a fan, the outlet must be four times the area of the fan inlet. Ensure that each Power Series is within an unobstructed airstream.
2. Vortex coolers operate on compressed air and provide good cooling on a sealed enclosure, but are noisy and consume a lot of air.
3. Cabinet air conditioners work well on sealed enclosures.
4. Heat pipe coolers work well on sealed enclosures, but do not provide as much cooling as vortex coolers or air conditioners.

To determine how much cooling is required:

1. Determine the amperage load on the Power Series. Multiply the amperage by 1.2 and then by the number of phases controlled. This is the output power dissipated by the SCRs in watts. Add the watts dissipated by the controller's power supply (21W) and multiply the total power in watts by 3.41 to get BTUs per hour. Vortex coolers, heat pipe coolers, and air conditioner cooling are rated in BTUs removed.
2. Add up the watts generated by other electronics in the enclosure and multiply by 3.41 to get BTUs per hour.
3. Add up the total BTUs inside the enclosure and pick a cooling device that will remove that amount of BTUs.
4. For fan cooled enclosures, enclosure and fan manufacturers usually have free software programs and application notes to help size the fans for enclosures. If necessary, contact the Application Engineers at Watlow Controls for assistance.

Harsh Environment

The Power Series meets standards UL508, Pollution degree 3 for safety which states: "Conductive pollution occurs or non-conductive pollution occurs which becomes conductive due to condensation which is to be expected." However, Watlow recommends that the Power Series be used in a clean, dry environment to ensure long-term reliability.



CAUTION:
You may want to use a large screwdriver to press in on the release tab while you are pushing on the controller to avoid potential injury to your hands.

Removing the Power Series Controller

1. To release the Power Series controller from the mounting plate, press in on the release tab at the top of the mounting plate.
2. When the release tab is in, push up on the controller from the bottom to release it from the mounting plate. **Beware of sharp edges on the heat sink when you push upward. This will take some force!**



Figure 2.4 — Removing the controller.

Maintaining the Power Series

- **Cleaning:** The heatsink fins must be kept clean for proper cooling and the printed circuit board should be free of conductive residue condensation.
- **Calibration:** Not normally necessary. See pages 6.15-6.16 for data restore and backup.
- **Retorquing:** See page 3.1 for torque guidelines.
- **Software backup and refresh:** Not necessary; see page A.7, Power Series Backup.

NOTE: All Power Series controllers have been 100 percent tested before shipment. The records of these tests are on file for recall if necessary.

Power Series Output Rating Curves

Fan Cooled

All curves are at 100% on with 90°C rated load wire and line wire connected. Note that each chart is slightly different on the amperage scale. The safe operating region is from 1 amp up to the specific curve for the output amperage code selected. For example: F25 Single Phase is rated up to 200 amps at 50°C; F30 Single Phase is rated for 250 amps at 50°C. See page 2.6 for Natural Convection Cooled output rating curves.

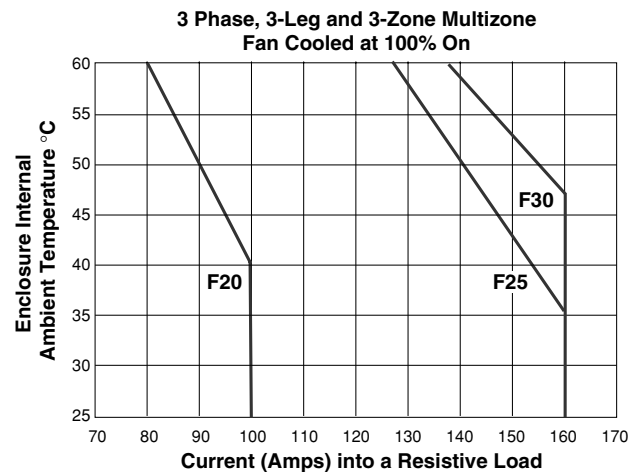
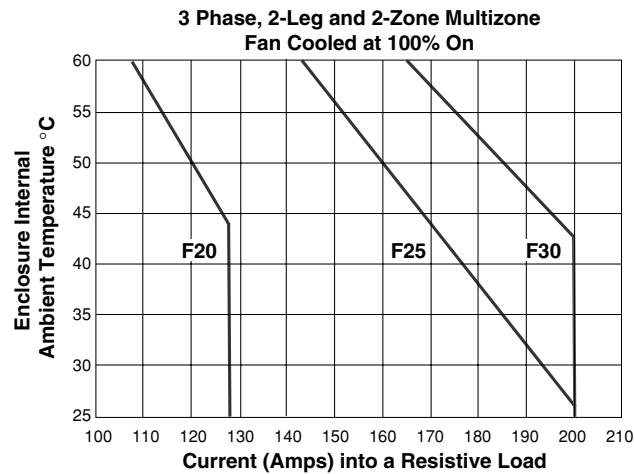
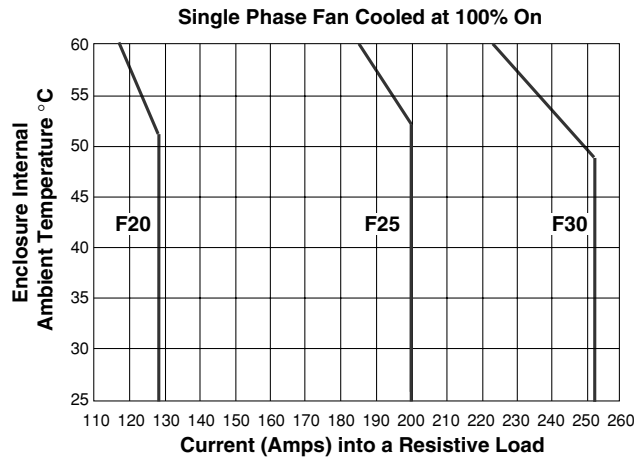

Power Series Output Rating Curves

Natural Convection

All curves are at 100% on and with 90°C rated load wire and line wire connected. Note that each chart is slightly different on the amperage scale. The safe operating region is from 1 amp up to the specific curve for the output amperage code selected. For example: N25 Single Phase is rated up to 140 amps at 50°C; N30 Single Phase is rated for 165 amps at 50°C.

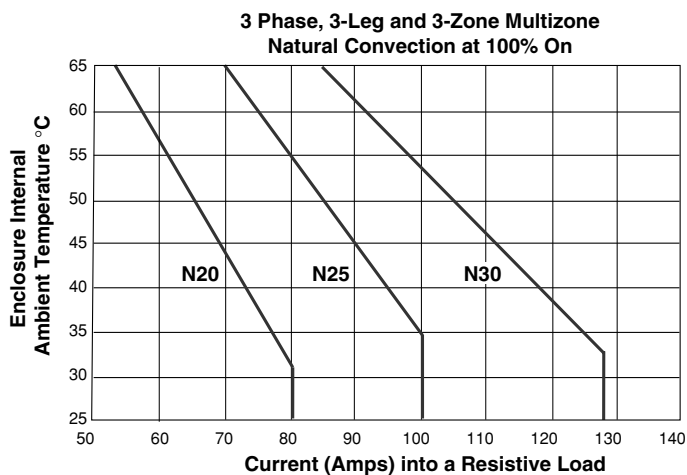
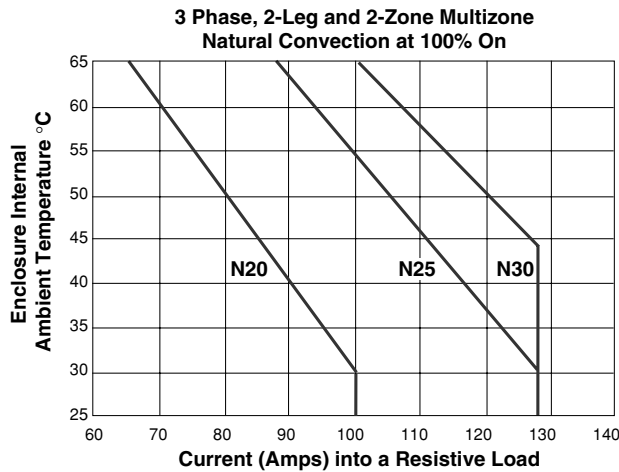
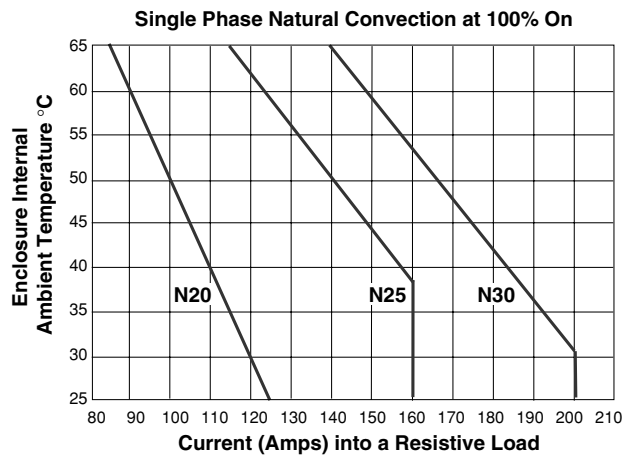

Chapter Three Wiring

Wiring the Power Series Controller

Wiring options depend on the model number. Check the terminal designation stickers on the right side of the controller and compare your model number to those shown here and with the model number breakdown in the Appendix (page A.10) of this manual.

Chapter 3 illustrates how to wire the inputs and outputs for all options. Refer to Figure 3.1 for terminal torque guidelines.

Torque Guidelines

- Properly torque terminals by holding for 30 seconds to allow for wires to settle and minimize loosening due to cold flow.
- Re-torque all terminals after 48 hours.
- Establish a maintenance program to re-torque line and load terminations every 3-6 months.

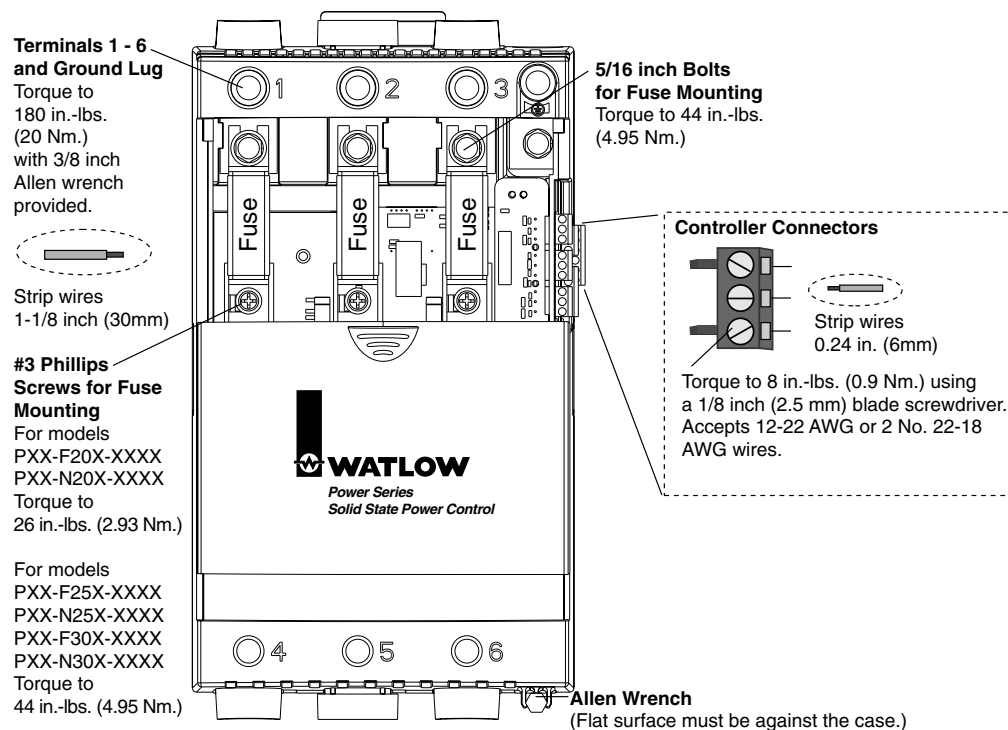

Figure 3.1 — Torque and wire stripping.

Input Wiring



WARNING:

To avoid damage to property and equipment, and/or injury or loss of life, use National Electric Code (NEC) standard wiring practices to install and operate the Power Series. Failure to do so could result in damage, and/or injury or death.

NOTE:

Input, retransmit and communications external terminals have been designed for protection in case of direct contact in accordance with European Standard EN50178.

NOTE:

Insure ground is wired with the same size wire as line and load connections to a ground of sufficient current carrying capacity. (Refer to Chapter 2, p. 2.1, Power Series Wire Bending Radius at Base Current and Ambient Temperature Rating.)

NOTE:

Torque and wire strip guidelines:

- Control wiring 1 thru 23.
- Strip wire to 0.24 inch (6mm). Torque to 8 in.-lbs. (0.9 Nm).
- Hold torque for 30 seconds to allow for wiring settling and cold flow. Re-torque after 48 hours.
- All line connections should be re-torqued every 3-6 months.

Figure 3.2a – Control Power and Alarm Wiring

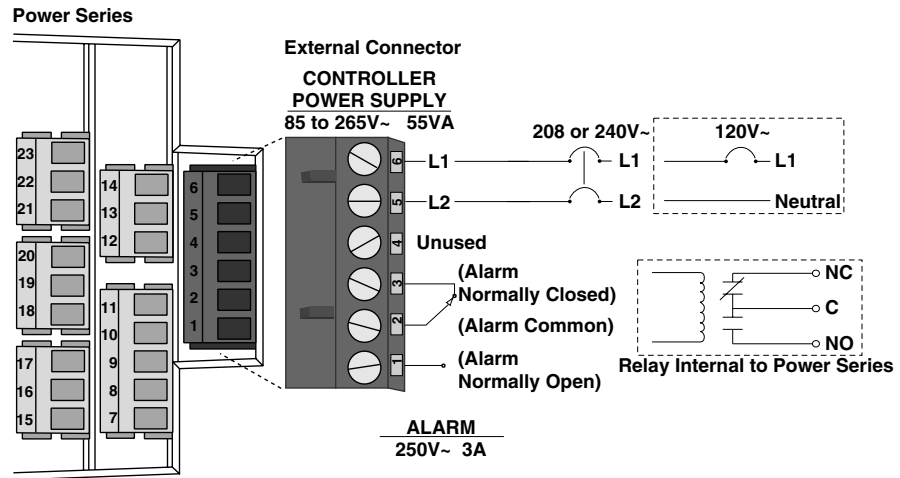

Figure 3.2b – Retransmit Wiring

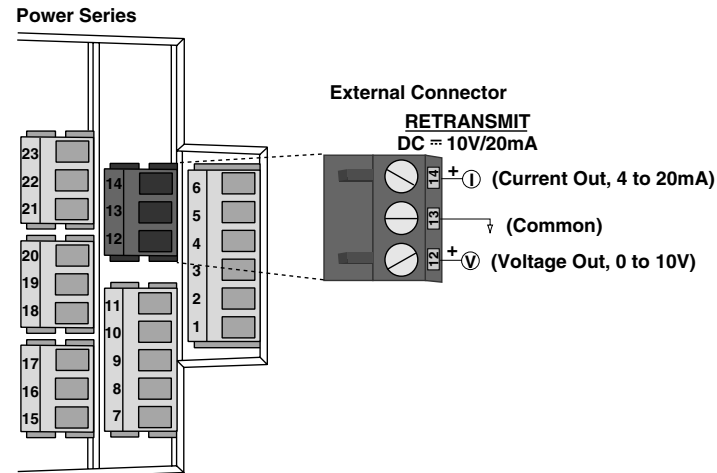

Figure 3.2c – Communications Wiring

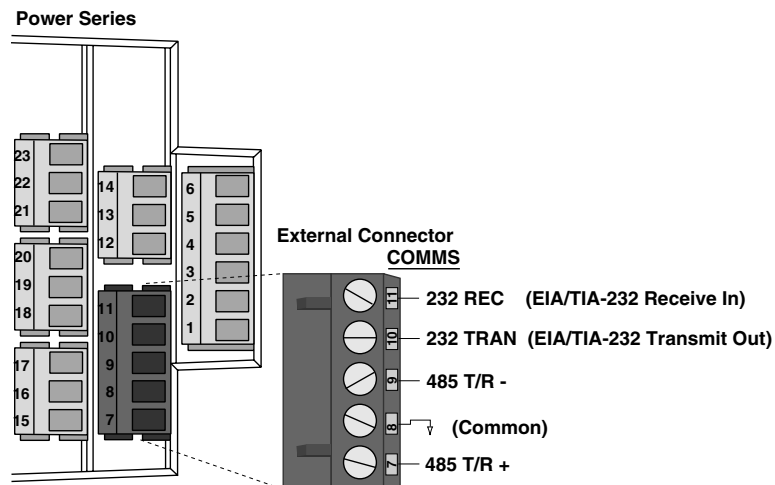

Figure 3.3a – Single Zone Input Wiring

NOTE:

Successful installation requires four steps:

- Choose the controller's hardware configuration and model number (Appendix);
- Install the controller (Chapter Two);
- Wire the controller (Chapter Three); and
- Configure the controller (Chapters Four, Five and Six).



WARNING:

To avoid damage to property and equipment, and/or injury or loss of life, use National Electric Code (NEC) standard wiring practices to install and operate the Power Series. Failure to do so could result in damage, and/or injury or death.

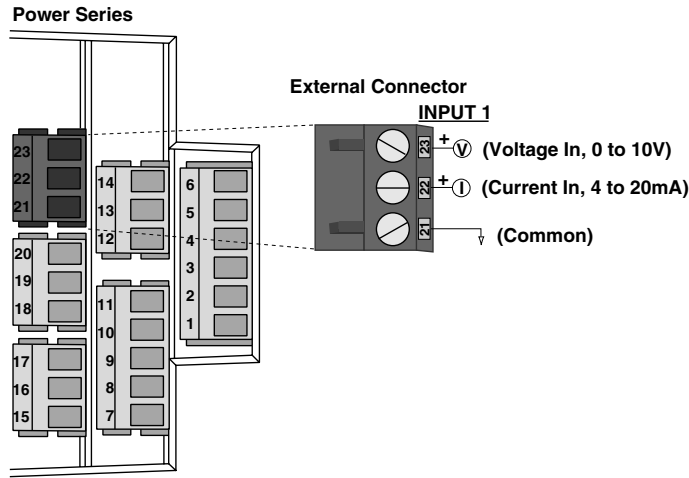

Figure 3.3b – 2-Zone Input Wiring

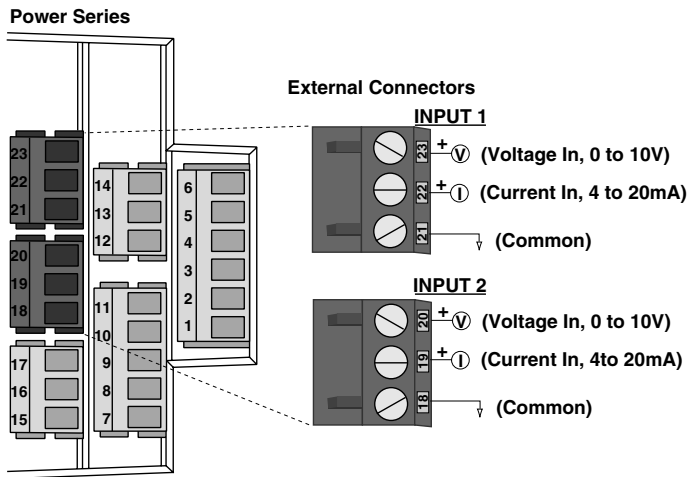
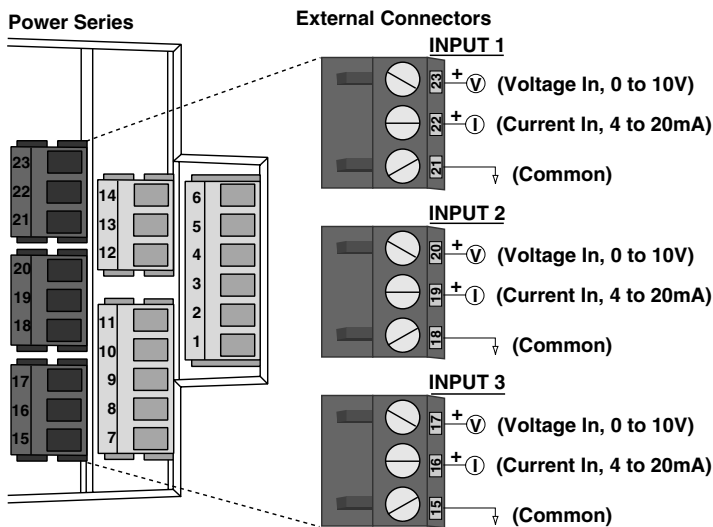

Figure 3.3c – 3-Zone Input Wiring



Line Power/Output Wiring

NOTE:

Successful installation requires four steps:

- Choose the controller's hardware configuration and model number (Appendix);
- Install the controller (Chapter Two);
- Wire the controller (Chapter Three); and
- Configure the controller (Chapters Four, Five and Six).



WARNING:

To avoid damage to property and equipment, and/or injury or loss of life, use National Electric Code (NEC) standard wiring practices to install and operate the Power Series. Failure to do so could result in damage, and/or injury or death.

NOTE:

Torque and wire strip guidelines:

- Connections 1 thru 6, and ground lug
- Strip wire 1-1/8 in. (30mm). Torque to 180 in.-lbs. (20 Nm).
- Hold torque for 30 seconds to allow for wiring settling and cold flow. Re-torque after 48 hours.
- All load connections should be re-torqued every 3-6 months.

Figure 3.4a – Single Phase Output Wiring (Model PC1X-XXXX-XXXX)

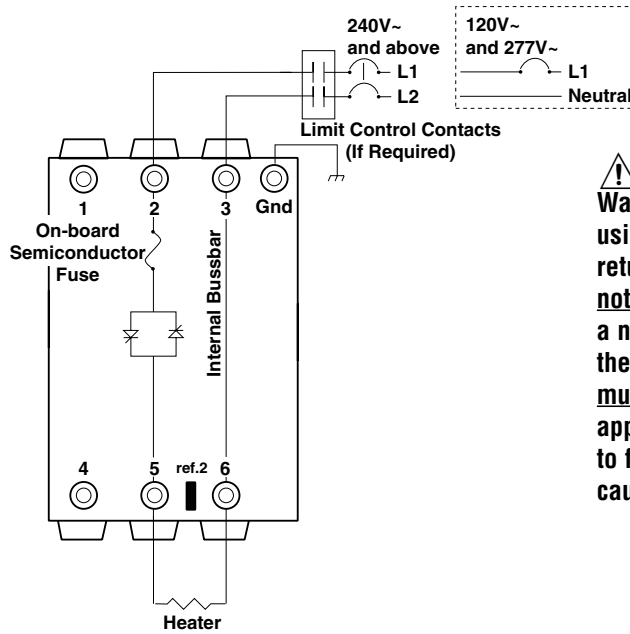

CAUTION: Figure 3.4a shows the Watlow-recommended output wiring using the internal bussbar as a return current path and with ref. 2 not connected. Should a user choose a non-recommended wiring scheme, then ref. 2 or the internal bussbar must be connected to the appropriate line or neutral. Failure to follow these guidelines could cause damage to the Power Series.

Figure 3.4b – 3 Phase, 2-Leg, 4 SCR Output Wiring (Model PC2X-XXXX-XXXX)

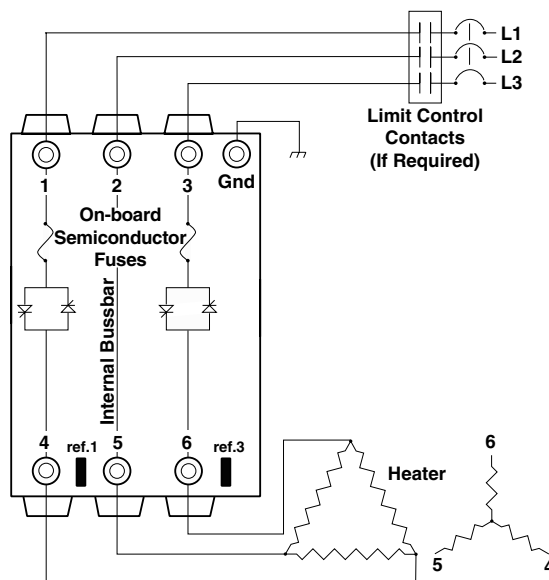

CAUTION: Figure 3.4b shows the Watlow-recommended output wiring using the internal bussbar as a return current path and with ref. 1 and 3 not connected. Should a user choose a non-recommended wiring scheme, then ref. 1 or ref. 3 or the internal bussbar must be connected to the appropriate line. Failure to follow these guidelines could cause damage to the Power Series.

NOTE: Our illustrations illustrate circuit breakers for branch circuit protection. Fuses can also be used.



WARNING:

To avoid damage to property and equipment, and/or injury or loss of life, use National Electric Code (NEC) standard wiring practices to install and operate the Power Series. Failure to do so could result in damage, and/or injury or death.



WARNING:

Install high or low temperature limit control protection in systems where an over temperature fault condition could present a fire hazard or other hazard. Failure to install temperature limit control protection where a potential hazard exists could result in damage to equipment, property and injury to personnel.

NOTE:

For reference connections 1 to 3, use QC 0.250 in. wide and 0.032 in. thick compatible connection which is fully insulated with nylon and has a metal grip ring.

For 14-16 AWG: Molex/ETC AA-5261; 3M MNG14-250DFIX C-54-503X or equivalent.

****NOTE:**

Models PC8 and PC9 control legs are isolated so that they may be wired from phase-to-phase inside delta or phase-to-neutral, independent of how the other legs are wired.

Figure 3.5a – 3 Phase, 3-Leg, 6 SCR, Output Wiring for 4-Wire Wye Application (Model PC4X-XXXX-XXXX)

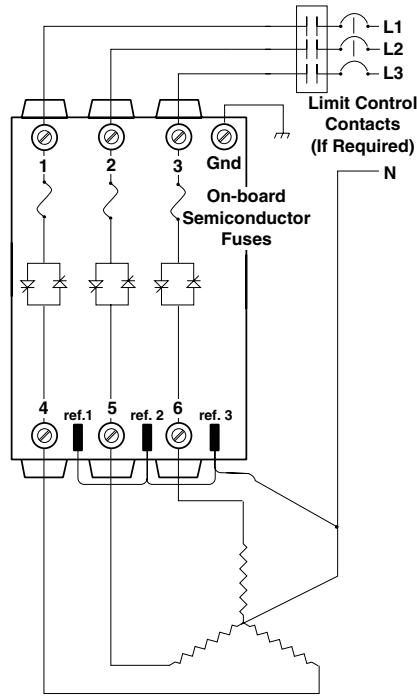
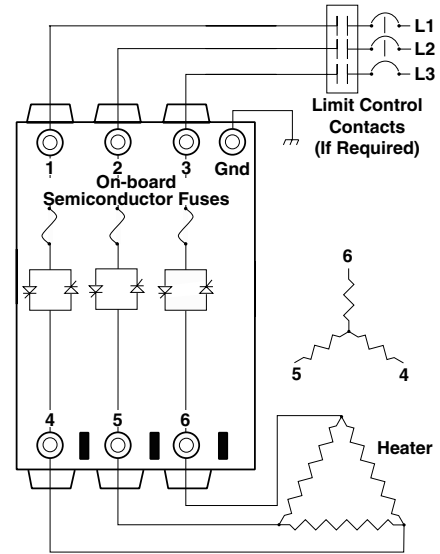
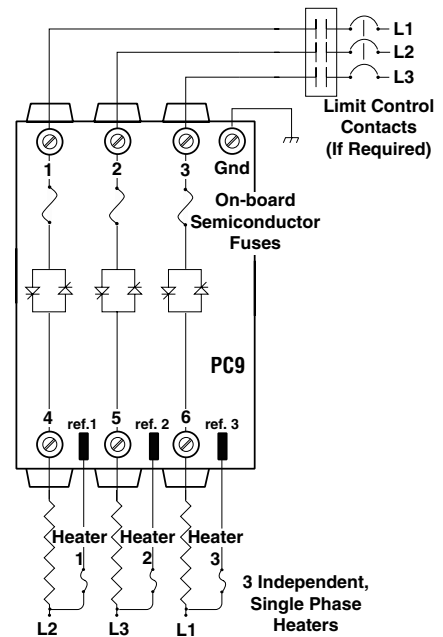
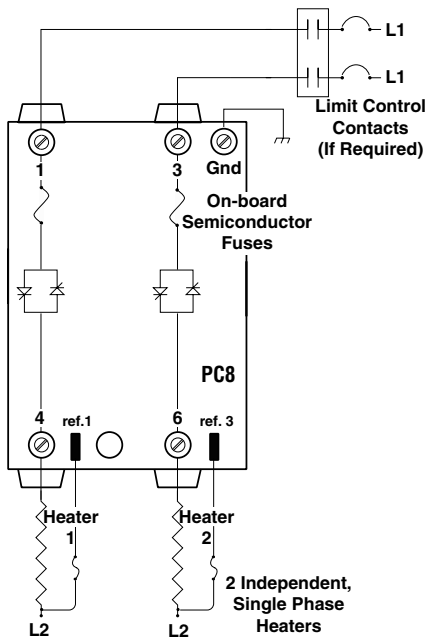

Figure 3.5b – 3 Phase, 3-Leg, 6 SCR Output Wiring (Model PC3X-XXXX-XXXX)



CAUTION: Do not connect ref. connections with PC3 models. Failure to follow this guideline could cause damage to the Power Series.

Figure 3.5c – **Multizone Output Wiring (Models PC8X-XXXX-XXXX and PC9X-XXXX-XXXX)



Wiring Example



WARNING:

To avoid damage to property and equipment, and/or injury or loss of life, use National Electric Code (NEC) standard wiring practices to install and operate the Power Series. Failure to do so could result in damage, and/or injury or death.



WARNING:

Install high or low temperature limit control protection in systems where an over temperature fault condition could present a fire hazard or other hazard. Failure to install temperature limit control protection where a potential hazard exists could result in damage to equipment, property and injury to personnel.

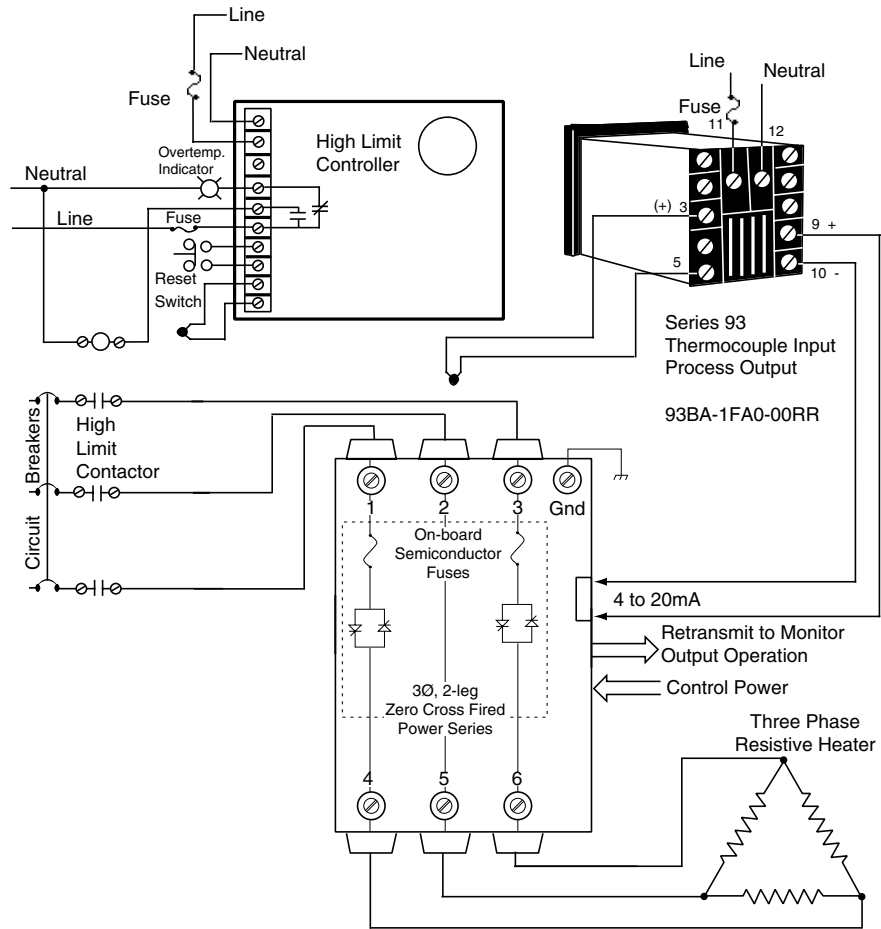

Figure 3.6 - System wiring example.

NOTE: Our wiring example illustrates circuit breakers for branch circuit protection. Fuses can also be used.

4

Chapter Four Navigation and Software

Keys and Displays

This chapter explains keys, displays and navigation skills. You'll also find a complete software map.

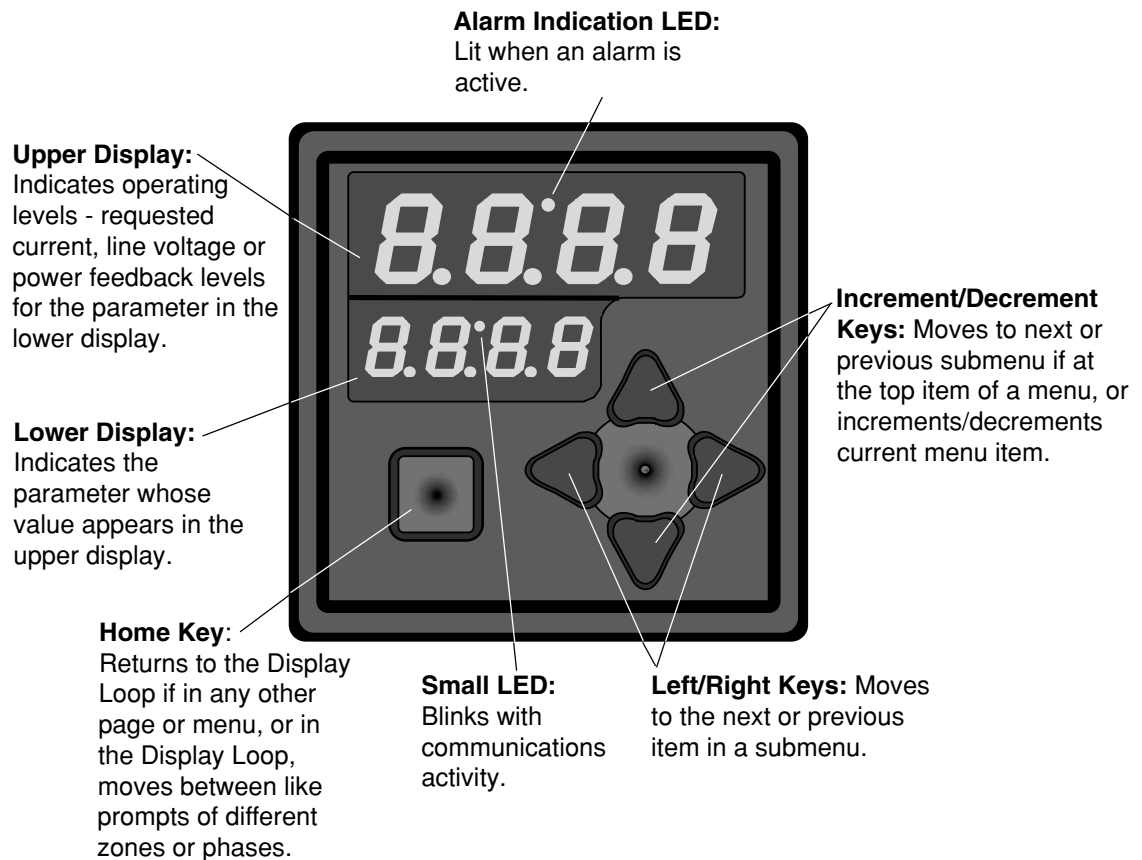
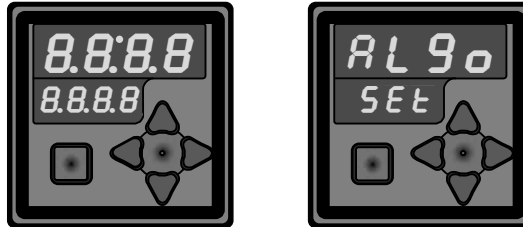

Figure 4.1 — Power Series keys and displays.

Navigating the Power Series

Choose a page (Setup or Factory) and press its key sequence. The page appears in the lower display.

Setup Page - for setting up the control, alarms, retransmit, and communications.



- **Setup Page:** From Display Loop, press **■** and **◀** keys together for 2 sec.

Factory Page - for calibration and diagnostic information.

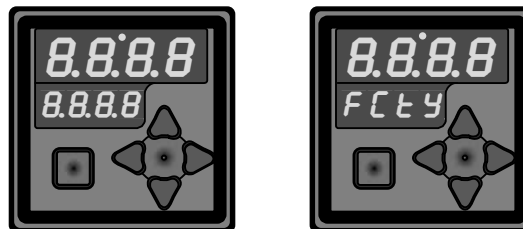

- **Factory Page:** From Setup Page, press **■** and **◀** and **▶** keys together for 2 sec

Display Loop - for monitoring parameters and adjusting manual/digital input, and for clearing alarms if they are latched.

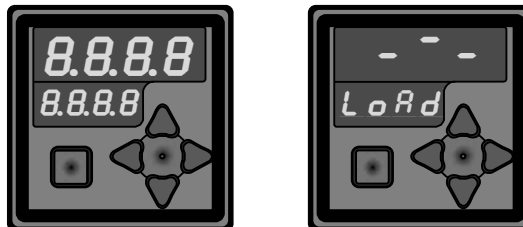

- **Display Loop:** From Setup or Factory Page, press the **■** key.

NOTE:

The Load Activity Indicator in the Display Loop indicates different things, dependent on whether heater diagnostics is installed. With heater diagnostics installed, it indicates load current has been detected. Without heater diagnostics installed, it indicates the SCRs are being gated and line voltage is present.

Press **▼** or **▲** to find a specific menu in a page. The menu appears in the upper display and the page remains in the lower display.

Press **▶** to enter the list of parameters in the menu displayed. The menu's parameters appear in the lower display and the values in the upper display. To go backward through the parameter list press **◀**.

Press **▼** or **▲** to select a value, either alpha or numeric, within a specific parameter.

Navigation

The Display Loop is used to monitor parameters and adjust manual/digital input, and to clear alarms if they are latched.

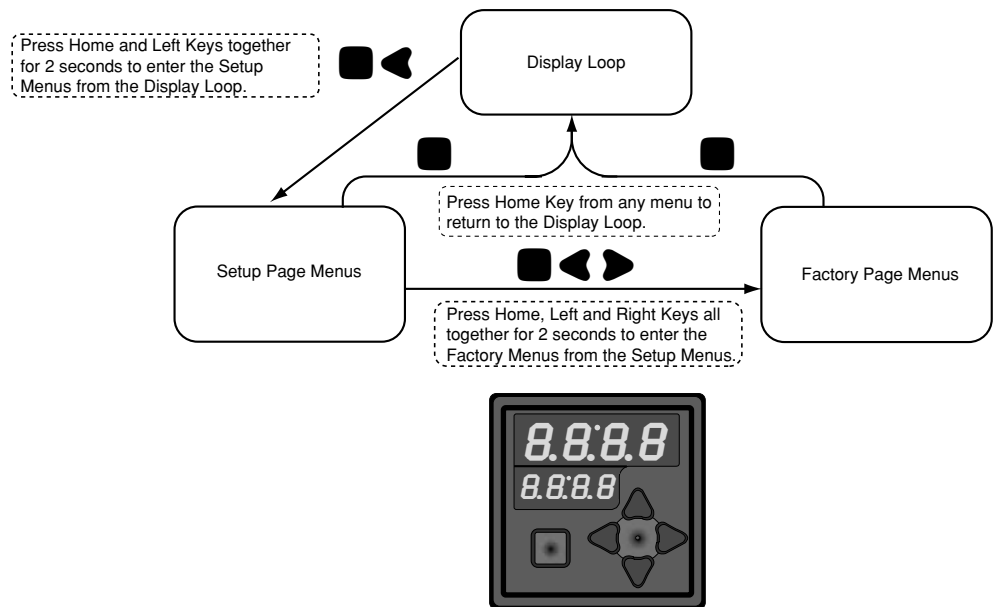

Display Loop

Use the Increment/Decrement keys (▲ ▼) to select a Zone or Phase within the Display Loop. The Zone/Phase appears in the upper display.

Use the Left/Right arrow keys (◀ ▶) to select a parameter within a Zone or Phase. The parameter appears in the bottom display.

Use the Increment/Decrement keys (▲ ▼) to select a value, either alpha or numeric, within a parameter. The value appears in the upper display.

Use the Home key (■) to toggle between Zones/Phase 1, 2, or 3 sequentially.

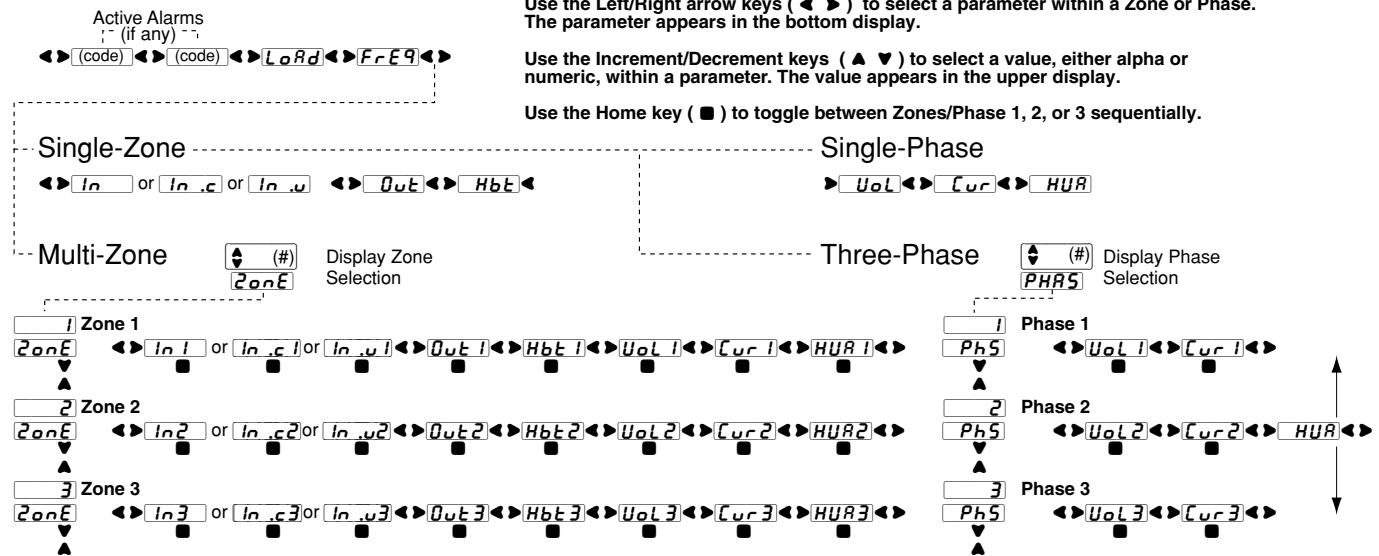

NOTES:

What you see in each Page and in each Menu are factory set, depending on the options and settings of your controller. The input signal method indicator will change depending on the input signal method chosen — digital, current, or volts. Current operating parameters may be modified at any time with the use of the keypad or communications port.

NOTE: For an explanation of the parameters in the Display Loop, range information, Modbus address, and conditions for the parameter to appear, see pp. 6.1-6.4, Chapter Six, Parameters.

Setup Page Menus



*NOTE: This prompt will only appear in [Ctrl], and if the controller is 3 phase.

Factory Page Menus

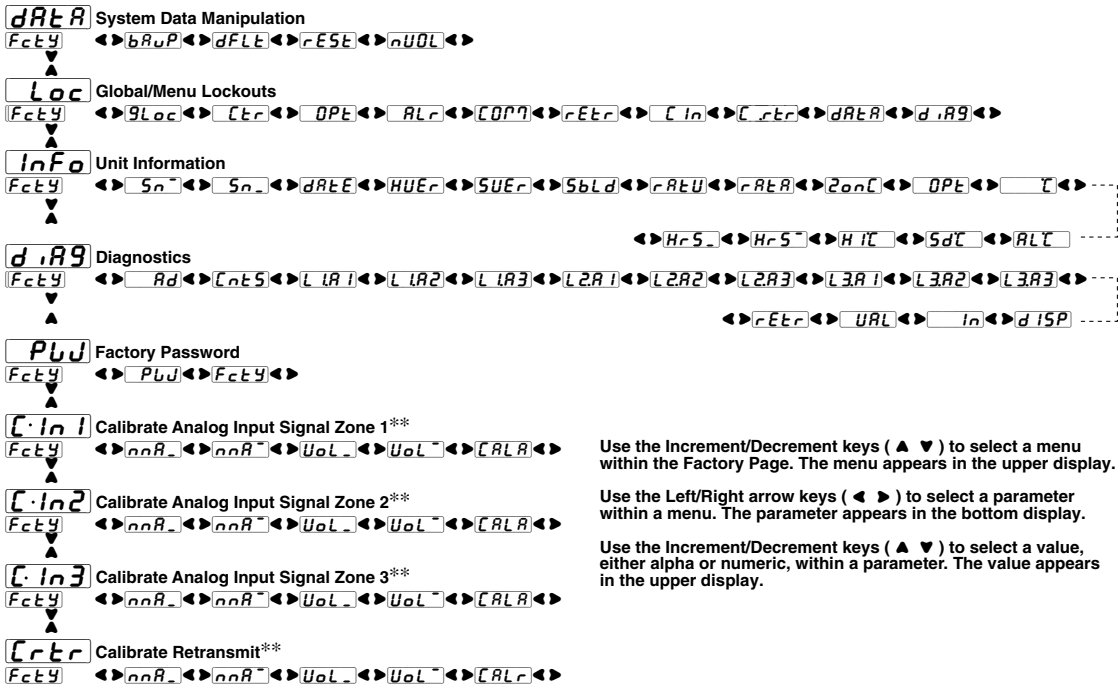

**NOTE: These menus and display prompts are only viewable in the Factory Mode using a password.

NOTE: For an explanation of the parameters in the Setup Page, (range information, Modbus address, and conditions for the parameter to appear), see Chapter Six, Parameters, pp. 6.5-6.14; for information on the Factory Page, see pp. 6.14-6.22.

Chapter Five

Control Methods and Features

Zero Cross

Zero cross (also known as burst firing) provides even output power with the lowest level of noise generation (RFI). Zero cross is the preferred method for controlling a resistive load.

The controller determines when the ac sine wave crosses the 0-volts point, then switches the load, minimizing RFI.

Zero cross control is available for all Power Series configurations.

Soft start and current limiting are not available with zero cross control.

Setup Page:

- Enter the Setup Page by holding **■ ◀** for 3 seconds.
- When the display reads **RL90**, press **▶** until **OFF** is displayed. Press **▲▼** to select **SEt** **RL90** is displayed. Press **▲▼** to select **FtB** fixed time base, zero cross or **UrtB** variable time base, zero cross.

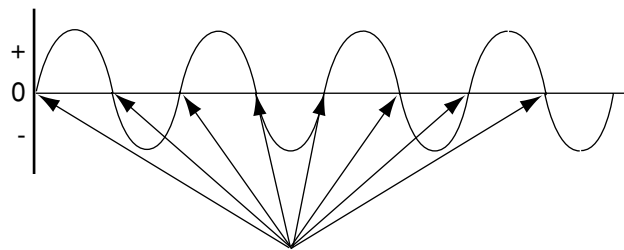

SCR Switch On/Off Points

Figure 5.1a — Zero cross switching.

Fixed Time Base - Zero Cross

In the fixed time base control method, the selected percentage power level output is generated over a fixed time period (i.e. a fixed number of cycles), regardless of power level selected. Resolution of operator selectable power may be more precise than the fixed time base allows. Selected power output level is rounded to the closest possible power output value in full cycles as necessary.

Line voltage compensation is not used in the fixed time base control method.

Setup Page:

- Enter the Setup Page by holding **■ ◀** for 2 seconds.
- When the display reads **RL90**, press **▶** until **OFF** is displayed. Press **▲▼** to select **SEt** **RL90** is displayed. Press **▲▼** to select **FtB** fixed time base, zero cross.
- Press **▶** until **1SEC** is displayed. Press **▲▼** to select **FtB** **1SEC** or **45EC**.

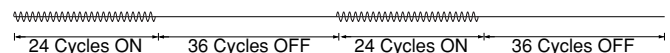

Figure 5.1b — 40% power, fixed time base, 60 Hz, 1 sec time base.

Variable Time Base - Zero Cross

In the variable time base control method, an optimal ratio of cycles on to cycles off is used to generate the desired power output. The number of cycles needed to completely generate a desired power level is variable in single cycle increments. Line voltage compensation algorithms are used to adjust the percentage power output while operating in this mode. Variable time base operation gives the best response time and resolution and provides for the longest heater life.

In single cycle variable time base below 50 percent power, the unit is never on for more than one consecutive full cycle. Above 50 percent power, the unit is not off for more than one consecutive full cycle while maintaining the proper output.

Line voltage compensation is active if selected; however, it can be disabled.

Setup Page:

- Enter the Setup Page by holding **■ ◀** for 2 seconds.
- When the display reads **AL90**, press **▶** until **OFF** **SET** **AL90** is displayed. Press **▲▼** to select **UrTb** variable time base, zero cross.

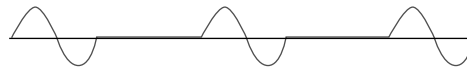

Figure 5.2a — 50% variable time base
1 cycle on, 1 cycle off.



Figure 5.2b — 40% single cycle variable time base
1 cycle on, 1 cycle off, 1 cycle on, 2 cycles off.

DC Contactor - Zero Cross

DC contactor control mode is a specialized version of zero cross control in which the analog control input is always used and percentage power output is fixed at 100 percent or 0 percent.

The off/on thresholds are 2.0V/3.5V for voltage input; 5.0mA/8.0mA for current input. This means the unit is off for an input voltage (current) of 2.0V(5.0mA) or lower, and 100% on for an input voltage (current) of 3.5V(8.0mA) or higher. Maximum input voltage is 10.0V.

To prevent excessive thermal cycling, the maximum cycle time should be 3 seconds or less.

Line voltage compensation is not used under dc contactor control, the output is either 100 percent on or 100 percent off.

Setup Page:

- Enter the Setup Page by holding **■ ◀** for 2 seconds.
- When the display reads **AL90**, press **▶** until **OFF** **SET** **AL90** is displayed. Press **▲▼** to select **cont** dc contactor.

NOTE: Heater Tolerance, Heater Open and Load Balance alarms do not work in DC Contactor control mode.

Phase Angle

The phase angle control method gates a limited portion of the line voltage cycle to the load based on percentage power selected. Soft start is always included when phase angle is selected.

Phase angle control may not be selected in a 3 phase, 2-leg system.

Line voltage compensation will be used to adjust the percentage power output while operating in this mode if selected.

Current limiting is a valid option with phase angle if the unit is equipped with heater diagnostics.

Setup Page:

- Enter the Setup Page by holding **■ ◀** for 2 seconds.
- When the display reads **AL90**, press **▶** until **OFF** **SET** **AL90** is displayed. Press **▲▼** to select **PH2E** phase angle.

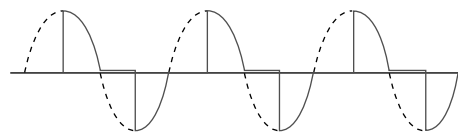

Figure 5.2c — Phase angle firing.

NOTE: The maximum output power is 99%. This is considered full on for the Power Series.

Soft Start

Soft start is a variation of phase angle control executed on **startup** in which there is a gradual increase in power until the final selected power output is reached. If soft start is selected, the system will execute the soft start sequence each time a zone starts active control. This happens at power-on and on recovery from an alarm such as “Line Loss.” The soft start time is the time it takes to achieve 100 percent power after a zone restart. The actual time may be greater than the set time because of the resolution, but the actual time will never be less than the set time. $\text{Rate} = 100.0 \div \text{time}$. The actual power achieved is set by the temperature control input (see Figure 5.3a and 5.4a).

NOTE: Soft start is intended to be used only for slowly increasing power on the initial power request.

Soft start is available in single phase and 3 phase, 3-leg models only.

Soft start is always used in systems with phase angle control mode selected unless **SoFT** is set to .

Setup Page:

Adjustable Soft Start - On Power Up

- Enter the Setup Page by holding **■ ◀** for 2 seconds.
- When the display reads **RL90**, press **▼** until **Cr1** is displayed. Press **▶** until **40** is displayed.

Use the **▲▼** keys to set the desired soft start time in seconds.

NOTE: Repeat this procedure for each zone that you wish to configure.

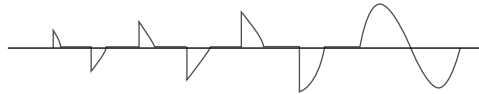

Figure 5.3a — Soft start.

Maximum Rate of Change

The maximum rate of change is used during **normal operation** of a phase angle controlled system (after a soft start sequence ends) to cause large changes in requested power to be implemented gradually. *The maximum rate of change of the power is defined as the percentage of power change allowed every 0.1 second.* This prevents a sudden increase or decrease in current from one phase angle level to another level from one cycle to the next into a nonlinear load that could be damaged or blow a fuse.

Setup Page:

Adjustable Maximum Rate of Change On

Signal Change

- Enter the Setup Page holding **■ ◀** for 2 seconds.
- When the display reads **RL90**, press **▼** until **Cr1** is displayed. Press **▶** until **10.0** is displayed.

Use the **▲▼** keys to set the desired % output change per 0.1 seconds to reach the desired output power level when in phase angle control.

Example:

Time needed for 100% change in power at selected **rRtE** :
 10.0% increase = 1 sec. from 0 to 100% power
 10.0% increase = 0.8 sec. from 10 to 90% power
 10.0% increase = 0.4 sec. from 10 to 50% power

NOTE: The default for Maximum Rate of Change is set to 10%/0.1 second.

NOTE: Repeat this procedure for each zone that you wish to configure.

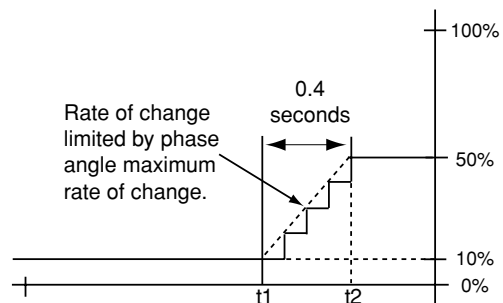

Requested power level changed from 10% to 50% at (time) t1.
 Actual power out has changed from 10% to 50% by t2.

Figure 5.3b — Maximum rate of change set to 10%.

Heater Bakeout

If a system is shut down for long periods, some heaters can absorb moisture. With a standard power controller, turning the power full “on” when moisture is present, can cause the fuses or the heater to blow. However, with the Power Series you can now “bake out” the moisture in a wet heater before applying full power and destroying the heater. During heater bakeout, the Power Series slowly increases voltage to the heater while monitoring the output current. If the heater achieves full output before the bakeout time expires, then the heater is dry and can be put into service. At all times, the output will not exceed the temperature controller set point.

If the output current reaches a user-specified trip point during the bakeout (as it would if arcing occurred in the heater), then the Power Series shuts off the output and activates an over-current trip error, **HbOC**. The operator should then lengthen the bakeout time and restart or just restart, depending on how long the initial bakeout ran. To start heater bakeout you must cycle the controller power. After a successful heater bakeout, the Power Series automatically switches to the operator pre-selected control mode (phase angle or zero cross).

NOTE: Heater bakeout is intended for magnesium oxide filled nichrome elements. A nichrome element heater can have a tolerance up to $\pm 10\%$. This tolerance could add to the maximum heater current during normal operation. For example, a 50-amp heater could draw 55 amps and still be a good and dry heater.

Heater bakeout may be selected in single phase (phase to neutral) and 3 phase, 6 SCR systems with any pre-selected control mode. You must also have

the heater diagnostics option installed on your Power Series.

Heater bakeout operates with an over-current trip. The operator must set the maximum current allowed during heater bakeout using the **HbOC** prompt. This will set the maximum allowable load during heater bakeout.

Setup Page:

- Enter the Setup Page by holding **■ ◀** for 2 seconds.
- When the display reads **RL 90**, press **▼** until **OP E 1** is displayed. Press **▶** until **OFF** is displayed.

Use the **▲▼** keys to turn heater bakeout on.

- Press **▶** until **77.0** appears in the lower display. Use the **▲▼** keys to set the desired heater bakeout time in minutes.
- Press **▶** until **HbC** appears in the lower display. Use the **▲▼** keys to set the desired maximum load current during the heater bakeout process.

NOTE: Repeat this procedure for each zone that you wish to configure.

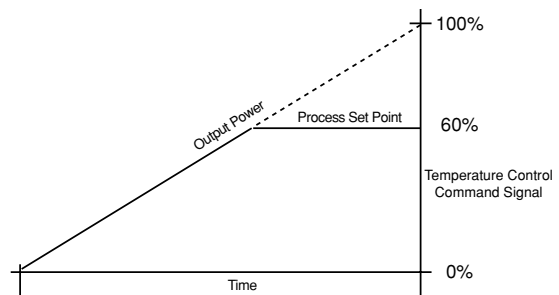

Figure 5.4a— Heater bakeout.

Heater Tolerance Detection

Heater tolerance detection allows you to detect a failed heater or a heater that is beginning to fail. An alarm is triggered if the load current drops below or rises above specific levels.

For example, if you have five heaters that draw 20 amps each, for a total load current of 100 amps at 100 percent power, you could program the heater tolerance alarm to trigger if the load current drops below 80 amps at 100 percent power. This would indicate that one of the heaters has failed (open.) To monitor for a heater that is beginning to fail or age, you could watch for too little or too much current. For example, in Figure 5.4b the alarm is programmed to trigger if the load current drops below 90 amps, or rises above 110 amps at 100 percent power.

The Power Series automatically adjusts the set points, depending upon the percent power, as shown in the illustration below.

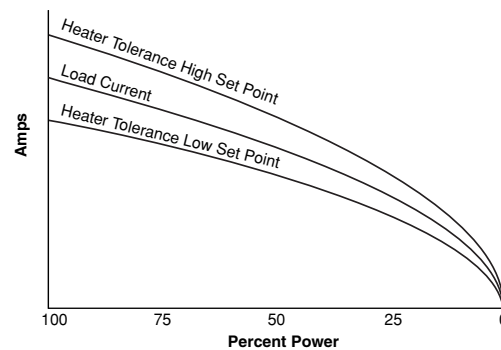

Figure 5.4b— Heater Tolerance Detection.

Current Limiting

The current limit uses the RMS current entered by the user. When a zone goes from 0.0% to a requested power greater than 0.0%, the software increments the output power by 0.1% increments per AC cycle until a current limit is detected. The software will continue to increment and decrement by 0.1% per AC cycle based on the current limit until the goal power is met.

During normal operation (after the initial goal power is met), a detected current limit will cause decrements at 0.1% power per AC cycle until the current limit is no longer active. The software will continue to increment and decrement by 0.1% per AC cycle based on the current limit, until the goal power is again met.

Current limiting is available on units equipped with heater diagnostics, (P __ 1 - ____ - ____).

Current limiting is not available with 3 phase, 2-leg systems.

Current limiting is available under phase angle control operation.

Setup Page:

- Enter the Setup Page by holding **■ ◀** for 2 seconds.
- When the display reads **AL90**, press **▼** until **OPT 1** is displayed. Press **▶** until **OFF** is displayed.

Use the **▲▼** keys to turn current limit on.

- Press **▶** until **CL A** appears in the lower display. Use the **▲▼** keys to set the desired current limit set point.

NOTE: Repeat this procedure for each zone that you wish to configure.

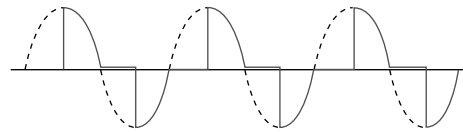

Figure 5.5 — Current limiting.

Inductive Load Adjustment

The effect of inductive loads on current readings with phase angle control can be factored in by requesting an Inductive Load Factor Adjustment. This feature is used to improve current measurement when phase angle firing into a transformer or other inductive loads.

The adjustment should be done with active phase angle control with a requested power of 5% to 50% in the zone of interest using a true RMS current meter.

NOTE: If an inductive load factor has been requested and the load is no longer inductive, the current reading will not be accurate. Use the **CLr parameter in the **IndF** prompt to remove the inductive factor.**

Setup Page:

- Enter the Setup Page by holding **■ ◀** for 2 seconds.
- When the display reads **AL90**, press **▼** until **OPT 1** is displayed. Press **▶** until **idLE** is displayed.

Using the **▲▼** keys, select **rE9** in the upper display.

- Press **▶** until **iCur** appears in the lower display. The upper display shows the current calculated by the system with no inductive factor. Read the actual current measured by a true RMS meter; use the **▲▼** keys until that value is displayed.
- Press **◀** until **IndF** appears in the lower display. Using the **▲▼** keys, select **ACt** in the upper display. After 5 seconds, the prompt will read **idLE** if the adjustment was successful, or **Err** if there was an error.
- To return to using no Inductive Load Factor, select **CLr**.

Other Features

Baseline Voltage and Voltage Compensation

The baseline voltage is used by the controller to adjust the output so that the system power remains constant. This adjustment is called voltage compensation. The requested power is assumed to occur at the baseline voltage. If there are any deviations of the line voltage from the baseline voltage, the applied output power will be adjusted.

For example, the starting line voltage of the system is 121 volts and the baseline voltage is set to 121 volts. The requested power is set to 50.0 percent. After the system has been controlling, the line voltage drops to 110 volts. During the time that the line voltage is at 110 volts, the applied output power will be adjusted to $(121^2/110^2) \times .50 = 60.5$ percent so that the system power remains constant.

The baseline voltage is also used for adjusting operating parameters in the software. It is important to adjust the baseline voltage to the normal operating voltage of the unit to enable it to operate at maximum accuracy.

Menu Lock

Menu locks allow a user to restrict access to parameters. If a lock is set on a menu, the parameters become read only. The system will not allow parameter to be changed, either from the keypad or through communications.

Factory Page:

- Enter the Factory Page by holding **■ ◀ ▶** for 2 seconds.
- When the display reads **dRtR**, press **▼** until **Loc** is displayed. Press **▶** until **UnL** is displayed.

Use Global Lockout **9LOC** to write protect all prompts by choosing locked **LOC**. If set to unlocked **UnL**, individual menu locks can be set by selecting each parameter in the Global/Menu Lockouts Menu and individually setting each to locked **LOC** or unlocked **UnL**.

Input

Signal Selection

You need to configure the Power Series for current, voltage or digital.

Setup Page:

- Enter the Setup Page by holding **■ ◀** for 2 seconds.
- When the display reads **AL90**, press **▼** until **Ctrl** is displayed. Press **▶** until **nnR** is displayed.

Use the **▲▼** keys to select either current **nnR**, volt **UoLE**, or digital **d.9**.

NOTE: Repeat this procedure for each zone that you wish to configure.

Analog is typically 0-5V \Rightarrow (dc), 1-5V \Rightarrow (dc), 0-10V \Rightarrow (dc), 4-20mA.

Digital is used for keypad manual control or communications to control the Power Series.

Digital input is entered from the keypad in the Display Loop on the **In1**, **In2** or **In3** prompt.

Current inputs are hardware limited to 0 to 20mA, but may be scaled using the **nnR₋** and **nnR₊** prompts. Note that the power will be fully off at the current specified by prompt **nnR₋** +.2mA, and fully on at the current specified by prompt **nnR₊** -.2mA.

Voltage inputs are hardware limited to 0 to 10V, but may be scaled using the **UoL₋** and **UoL₊** prompts. Note that the power will be fully off at the current specified by prompt **UoL₋** +.1V, and fully on at the current specified by prompt **UoL₊** -.1V.

Alarms

An alarm takes some action, usually notifying an operator, when a control parameter leaves a defined range. A user can configure how and when an alarm is triggered and whether it turns off automatically when the alarm condition is over. A description of the alarms and errors, why they occur, and how to troubleshoot them can be found on pages A.4 - A.7.

Setup Page:

- Enter the Setup Page holding **■ ◀** for 2 seconds.

- When the display reads **AL9o**, press **♥** until **ALr** is displayed.
SEE **SEE**

Global Alarm Configuration

The Global Alarm Configuration **9LbL** is used when all of the alarms in the system are to be configured in the same mode. If individual alarms need to be set to different configurations, the Global Alarm Configuration should be set to **OFF**.

Alarm Standard

If an alarm is configured as “standard” **SEd**, the alarm indicators only occur while the alarm is active. The alarm indicators are the relay, which state is set in Active Relay State **AL9c** as either energized on alarm or de-energized on alarm, and the display, which has an indicator LED in the upper display and the descriptive prompt for the active alarm. When the alarm becomes inactive (and no other alarms are active) the alarm indicators are turned off.

Alarm Latched & Unlatching an Alarm Indicator

If an alarm is configured as “latched” **LAL**, the alarm indicators remain active until the user deactivates them. For a latched alarm, the descriptive prompt on the display in the Display Loop will read **LAL**, and the user can switch to **UnLA**, if the alarm is cleared, to turn off the alarm indicators. Once alarm indicators have been turned off, the operator does not have to reconfigure an alarm as latched.

Alarm Silencing

If an alarm is configured as “silenced” **SIL**, the relay does not activate on the active alarm, although the display indicators are still visible. When the alarm becomes inactive (and no other alarms are active) the display alarm indicators are turned off.

Alarm Latched and Silenced

If an alarm is configured as “latched and silenced” **LASl**, only the display alarm indicators are active until the user deactivates them. The alarm displays must be switched off once the alarm has been cleared. See unlatching an alarm indicator above.

Active Relay State

For maximum flexibility, the Power Series controller can generate alarms from the energized or de-energized state of the relay. Creating an alarm from the de-energized state of the relay is the most reliable method of alarm generation since a power loss or any other control malfunction would cause an alarm.

Communications

Overview

A Power Series controller can also be programmed and monitored by connecting it with a personal computer or programmable logic controller (PLC) via serial communications. To use this communications option, a Power Series must be equipped with an EIA/TIA 232/485 (P_ _ _ - _ _ _ - 1 _ _ _) communications board.

To view or change controller settings with a personal computer, you need to run software that uses the Modbus™ RTU protocol to read or write to registers

in the controller. See Chapter Six, Parameters, for the Modbus registers. These registers contain the parameter values that determine how the controller will function and the values that reflect the current input and output values of the system.

Parameters relating to communications appear in the Comms Menu (Setup Page). Match the Baud Rate **bRud** to that of the computer and select an Address **Rddr** (1 to 247, default is 1).

The Power Series supports a maximum read of up to 32 registers. See appendix A.8 for Modbus registers.

Retransmit

Retransmitting Output Load Current or Load Power

The retransmit feature allows an output to retransmit an analog signal that can serve as an input variable for another device such as a chart recorder to document system performance over time.

To use the retransmit feature a Power Series must be equipped with heater diagnostics and a universal retransmit board (P__1 - ____ - _1__).

Setup Page:

- Enter the Setup Page by holding **■** **◀** for 2 seconds.
- When the display reads **AL90**, press **♥** until **rEt r** is displayed. Press **▶**:

is displayed. Press **▶**:

Select **[CF9]** to choose the type of output retransmitted, mA **[mA]** or volts **[VOLT]**.

Select **[TYPE]** to choose the type of information that will be retransmitted.

[None] retransmit not active.

[CUR] retransmits the load current of selected phase **[PHAS]** or zone **[ZONE]** if it is a multizone unit.

[HUA] retransmits the load power of selected zone **[ZONE]** in all models.

Select phase **[PHAS]** or zone **[ZONE]** to choose the phase/zone that will represent your retransmit signal. A three phase unit can only be single zone.

To scale the retransmit output signal, set the low value load current or kVA to be retransmitted with **[Cur_]** or **[HUA_]** and set the high value load current or kVA to be retransmitted with **[Cur^]** or **[HUA^]**. For example, if you want 4-20mA to represent a 50A to 250A current, set **[Cur_]** to 50 and **[Cur^]** to 250. As the load current varies between 50 and 250A, the retransmit output will vary between 4mA and 20mA.

Current outputs are hardware limited to 0 to 20mA, but may be scaled using the **[rE .C_]** and **[rE .C^]** prompts.

Voltage outputs are hardware limited to 0 to 10V, but may be scaled using the **[rE .U_]** and **[rE .U^]** prompts.

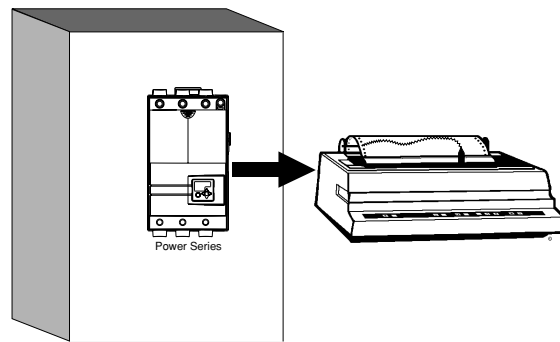

Figure 5.9a — Retransmitting a remote set point.

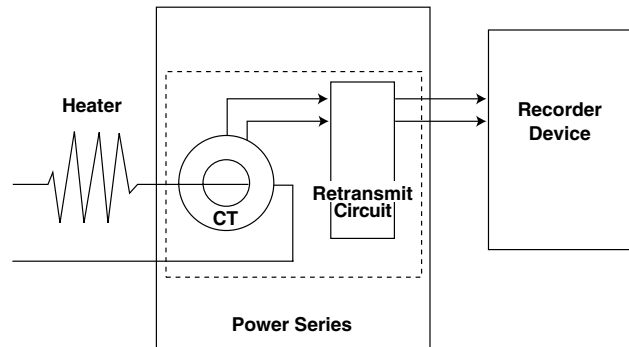

Figure 5.9b — Example circuit.

Fast Start Guide

Get Your Power Series Controlling Heat

Single Phase Control

Apply power to the line and the electronics power supply. The displays will read

- Enter the Setup Page holding for 2 seconds.
 - When the display reads to ,
- then cycle thru the list of choices using the keys. Choose one*.

dc contactor
 non-operational
 fixed time base, zero cross
 variable time base, zero cross
 phase angle

- At , press to .
- **Press until (default) is displayed.

Using the keys, select input type: off, current, voltage, or keyboard or comms.

- **Press until or is displayed.

Using the keys, set the low end of the input scale to the desired input.

- **Press until or is displayed.

Using the keys, set the high end of the input scale to the desired input.

- **Press until is displayed.

Using the keys, select , and the Power Series will set the baseline voltage. Line voltage compensation, under voltage alarm, and some internal operating parameters are based on this.

***NOTE: One type of power control algorithm must be selected for all zones.**

****NOTE: Repeat this procedure for each zone in multizone configurations.**

Three Phase Control

Apply power to the line and the electronics power supply. The displays will read

- Enter the Setup Page holding for 2 seconds.
 - When the display reads to ,
- then cycle thru the list of choices using the keys. Choose one.

dc contactor
 non-operational
 fixed time base, zero cross
 variable time base, zero cross
 phase angle

- At , press to .
- **Press until (default) is displayed.

Using the keys, select input type: off, current, voltage, or keyboard or comms.

- Press until or is displayed.

Using the keys, set the low end of the input scale to the desired input.

- Press until or is displayed.

Using the keys, set the high end of the input scale to the desired input.

- Press until is displayed.

Select the load type for Zone 1. (Choice is dependent on unit hardware.)

3 ph, 2-leg delta
 3 ph, 2-leg open delta
 3 ph, 2-leg ungrounded wye
 unconfigured
 3 ph, 3-leg, 6 SCR inside delta
 3 ph, 3-leg, 6 SCR delta
 3 ph, 3-leg, 6 SCR grounded wye

- Press until is displayed.

Using the keys, select , and the Power Series will set the baseline voltage. Line voltage compensation, under voltage alarm, and some internal operating parameters are based on this.

6

Chapter Six Parameters

Display Loop

The resting-state display shows one of the following sets of data, depending on controller setup. The first prompt appears in the top display, the second in the bottom display.

Display	Parameter	Range (Modbus Value)	Default	Modbus Register read/write	Conditions for Parameters to Appear
System Information					
<input type="checkbox"/> (alpha)	Active Alarms (if any) Displays present alarm conditions.	<input type="checkbox"/> ALr Active (1) <input type="checkbox"/> LAR Latched Active (2) <input type="checkbox"/> LRI Latched Inactive (3) <input type="checkbox"/> UnLR Unlatched (4)		181 to 190 r/w	Active: Any active unmasked alarm. Individual Modbus registers may have <input type="checkbox"/> UnLR Unlatched (4) written to them to clear a latched alarm. NOTE: a latched alarm must be <input type="checkbox"/> LRI Latched Inactive (3) before it can be unlatched.
<input type="checkbox"/> (alpha)	Display Loop Errors (if any) Displays present error conditions.	<input type="checkbox"/> Inactive (0) <input type="checkbox"/> Err Active (1) (See Appendix A.7 for values)	n/a	195 r	Active: Any active error. See Appendix, pp. A.4-7.
<input type="checkbox"/> LoRd	Load Activity Indicator Displays <input type="checkbox"/> - if load has power applied.	<input type="checkbox"/> - or <input type="checkbox"/> - per display	<input type="checkbox"/> - - -		Active: Always. Appears in display loop. (In single phase, single zone, only the center LED operates; in single phase, 2-zone, or 3-phase, 2-leg, only the outside LEDs operate; in 3-phase, 3-leg, and multizone, each zone operates a separate LED.)
<input type="checkbox"/> FrEq	Line Frequency (Hz) Displays the AC line.	<input type="checkbox"/> 47 to <input type="checkbox"/> 63 [47 to 63]	n/a	198 r	Active: Always. Appears in Display Loop.
Single Zone / Single Phase					
<input type="checkbox"/> in	Analog (mA or V) or Numeric (%) Input Signal Displays mA/V analog input; selects numeric % power.	<input type="checkbox"/> 00 to <input type="checkbox"/> 2000 [mA] (0 to 2000) <input type="checkbox"/> 00 to <input type="checkbox"/> 1000 [V] (0 to 1000) <input type="checkbox"/> 00 to <input type="checkbox"/> 1000 [%] (0 to 1000) 0.1 increments	<input type="checkbox"/> 00	150 r [mA] 151 r [V] 5102 r/w [dig]	Active: Always. Appears in Display Loop.

Display	Parameter	Range (Modbus Value)	Default	Modbus Address read/write	Conditions for Parameters to Appear
OUT	Output Power (%) Displays present output power.	00 to 1000 (0 to 1000)	00	159 r	Active: Always. Appears in Display Loop.
HbE	Heater Bakeout Timeout Displays the time left on a heater bakeout.	9999 to 0 [minutes] (9999 to 0)	n/a	157 r [1]	Active if heater diagnostics option is installed and heater bakeout is running in the zone.
UoL	Line Potential (Volts) rms Displays measured line voltage.	0 to 9999 (0 to 9999)	n/a	162 r	Active: Always. Appears in Display Loop.
Cur	Load Current (Amps) rms Displays measured load current. Peak current converted to rms, then multiplied by % power = average rms current measured by the on-board CT.	0 to 9999 (0 to 9999)	n/a	164 r	Active if heater diagnostics option is installed.
HUR	Load Power (kVA) Displays (est.) calculated load power.	0 to 9999 (0 to 9999)	n/a	156 r	Active if heater diagnostics option is installed.

Two Zone, Single Phase

Zone 1, Zone 2	Display Zone Selection Select Zone 1 or 2 for display.	1 to 2	1	n/a	Active with multizone configuration.
In 1, In 2	Analog (mA or V) or Numeric (%) Input Signal Displays mA/V analog input; selects numeric % power.	00 to 1000 [V] (0 to 1000) 00 to 2000 [mA] (0 to 2000) 00 to 1000 [%] (0 to 1000) 0.1 increments	00	mA, r [1][2] 150,160 V, r [1][2] 151,161 dig, r/w [1][2] 5102, 5202	Active with multizone configuration.
OUT 1, OUT 2	Output Power (%) Displays present output power.	00 to 1000 (0 to 1000)	00	159 r [1] 169 r [2]	Active with multizone configuration.
HbE 1, HbE 2	Heater Bakeout Timeout Displays the time left on a heater bakeout.	9999 to 0 [minutes] (9999 to 0)	n/a	157 r [1] 167 r [2]	Active if heater diagnostics option is installed and heater bakeout is running in the zone.

Display	Parameter	Range (Modbus Value)	Default	Modbus Address read/write	Conditions for Parameters to Appear
UoL 1 , UoL 2	Line Potential (Volts) rms Read measured line voltage.	<input type="text" value="0"/> to <input type="text" value="9999"/> (0 to 9999)	n/a	152 r [1] 172 r [2]	Active with multizone configuration.
Cur 1 , Cur 2	Load Current (Amps) rms Read measured line current.	<input type="text" value="00"/> to <input type="text" value="9999"/> (0 to 9999)	n/a	154 r [1] 174 r [2]	Active with multizone configuration and heater diagnostics option is installed.
HUA 1 , HUA 2	Load Power (kVA) Read calculated (est.) load power.	<input type="text" value="0"/> to <input type="text" value="9999"/> (0 to 9999)	n/a	156 r [1] 166 r [2]	Active with multizone configuration and heater diagnostics option is installed.

Three Zone, Single Phase

<input type="text" value="1"/> , <input type="text" value="2"/> , <input type="text" value="3"/>	Display Zone Selection Select Zone 1, 2 or 3 for display.	<input type="text" value="1"/> to <input type="text" value="3"/>	1	n/a	Active with multizone configuration.
In 1 , In 2 , In 3	Analog (mA or V) or Numeric (%) Input Signal Displays mA/V analog input; selects numeric % power.	<input type="text" value="00"/> to <input type="text" value="2000"/> [mA] (0 to 2000) <input type="text" value="00"/> to <input type="text" value="1000"/> [V] (0 to 1000) <input type="text" value="00"/> to <input type="text" value="1000"/> [%] (0 to 1000) 0.1 increments	<input type="text" value="00"/>	mA, r[1][2][3] 150,160,170 V, r[1][2][3] 151,161,171 dig, r/w [1][2][3] 5102, 5202, 5302	Active with multizone configuration.
Out 1 , Out 2 , Out 3	Output Power (%) Displays present output power.	<input type="text" value="00"/> to <input type="text" value="1000"/> [%] (0 to 1000)	<input type="text" value="00"/>	159 r [1] 169 r [2] 179 r [3]	Active with multizone configuration.
HbE 1 , HbE 2 , HbE 3	Heater Bakeout Timeout Displays the time left on a heater bakeout cycle.	<input type="text" value="9999"/> to <input type="text" value="0"/> [minutes] (9999 to 0)	n/a	157 r [1] 167 r [2] 177 r [3]	Active if heater diagnostics option is installed and heater bakeout is running in the zone.
UoL 1 , UoL 2 , UoL 3	Line Potential (Volts) rms Read measured line voltage.	<input type="text" value="0"/> to <input type="text" value="9999"/> [V] (0 to 9999)	n/a	152 r [1] 162 r [2] 172 r [3]	Active with multizone configuration.

NOTES:

What you see in each Page and in each Menu are factory set, depending on the options and settings in your controller. Current operating parameters may be modified at any time with the use of a keypad or serial input.

The Input Signal Method Indicator will change depending on the Input Signal Method chosen — process, current, or volts. NOTE: For more information about how parameter settings affect the controller's operation, see Chapter Five, Control Methods and Features.

Display	Parameter	Range (Modbus Value)	Default	Modbus Address read/write	Conditions for Parameters to Appear
[Cur 1], [Cur 2], [Cur 3]	Load Current (Amps) rms Read measured line current.	[00] to [9999] [A] (0 to 9999)	n/a	154 r [1] 164 r [2] 174 r [3]	Active with multizone configuration and heater diagnostics option is installed.
[HUR 1], [HUR 2], [HUR 3]	Load Power (kVA) Read calculated (est.) load power.	[0] to [9999] [kVA] (0 to 9999)	n/a	156 r [1] 166 r [2] 176 r [3]	Active with multizone configuration and heater diagnostics option is installed.

Multi-Phase

[In]	Analog (mA or V) or Numeric (%) Input Signal Displays mA/V analog input; selects numeric % power.	[00] to [2000] [mA] (0 to 2000) [00] to [1000] [V] (0 to 1000) [00] to [1000] [%] (0 to 1000) 0.1 increments	[00]	151 r [V] 150 r [mA] 5102 r/w [dig]	Active: Always. Appears in Display Loop.
[Out]	Output Power (%) Displays present output power.	[00] to [1000] [%] (0 to 1000)	[00]	159 r	Active: Always. Appears in Display Loop.
[1], [2], [3] [PhAS]	Display Phase Selection 1 to 3 Select phase for display.	[1] to [3]	n/a		Active with multiphase configuration.
[UoL 1], [UoL 2], [UoL 3]	Line Potential (Volts) rms Read measured line voltage.	[00] to [9999] [V] (0 to 9999)	n/a	152 r [1] 162 r [2] 172 r [3]	Active with multiphase configuration.
[Cur 1], [Cur 2], [Cur 3]	Load Current (Amps) rms Read measured load current.	[00] to [9999] [A] (0 to 9999)	n/a	154 r [1] 164 r [2] 174 r [3]	Active with multiphase configuration and heater diagnostics option is installed.

NOTE: In 3 phase, 2-leg systems, **[Cur 2]** is the current displayed; it is the average of phase 1 and phase 3 (**[Cur 1]** and **[Cur 3]**).

[HUR]	Load Power (kVA) Read calculated (est.) load power.	[0] to [9999] [kVA] (0 to 9999)	n/a	156 r	Active with multiphase configuration and heater diagnostics option is installed.
--------------	---	--	-----	-------	--

Setup Page

To enter the Setup Page, press the Home and Left keys (**■** **◀**) together while in the Display Loop.

Each of the following menus in the Factory Page are selected by pressing the Increment/Decrement keys (**▲** **▼**). Each press of the button will scroll you up or down through these main menu options.

To select a parameter within a menu, use the Left/Right arrow keys (**◀** **▶**). The parameter appears in the bottom display.

To select a value for each parameter (either alpha or numeric), use the Increment/Decrement keys (**▲** **▼**). The value appears in the upper display.

Pressing the Home key (**■**) in this menu will return you to the Display Loop.

The Setup Page contains ten menus:

Display	Parameter	Range (Modbus Value)	Default	Modbus Register read/write	Conditions for Parameters to Appear
SEt	Setup Page Select Go to a setup menu.	AL90 Control Algorithm CEr1 Control Zone 1 OPt1 *Options Zone 1 CEr2 Control Zone 2 OPt2 *Options Zone 2 CEr3 Control Zone 3 OPt3 *Options Zone 3 ALr Alarms Configuration COm *Comms Configurations rEt *Retransmit Configuration	AL90		*NOTE: These menus are dependent on the hardware options that are installed in your controller. Please see the individual menus for the options that must be installed for each of these menus to appear.

AL90 Setup Control Algorithm

SEt Setup Page

This menu is used to set the control algorithm for the system.

NOTE: Changing the algorithm will restart the system.

AL90	Power Control Algorithm Select Select power control algorithm.	cont dc contactor (0) OFF non-operational (1) Ftbb fixed time base, zero cross (2) Urtbb variable time base, zero cross (3) PH2E phase angle (4)	OFF non-operational (1)	55 r/w	Active: Always. cont is not available if any input on controller is digital. PH2E phase angle is not available with 3 phase, 2-leg controllers. NOTE: Changing this parameter will restart the system.
Ftbb	Fixed Time Base (Sec) Set the fixed time base in seconds for selected zone.	1SEC 1 second (0) 4SEC 4 second (1)	1SEC 1 second (0)	56 r/w	Active if AL90 is set to Ftbb .

NOTE: For more information about how parameter settings affect the controller's operation, see Chapter Five, Control Methods and Features.

Display	Parameter	Range (Modbus Value)	Default	Modbus Address read/write	Conditions for Parameters to Appear
<input type="checkbox"/> UC	Line Voltage Compensation Automatically adjusts output duty cycle to compensate for line voltage fluctuations.	<input type="checkbox"/> ON on (0) <input type="checkbox"/> OFF off (1)	<input type="checkbox"/> ON on (0)	80 r/w	Active: Always.

[Err 1] [Err 2] [Err 3] **Setup Control Zone 1, 2, and 3 Menus**
 SEt SEt SEt **Setup Page**

This menu is used to set up the control for the chosen zone.

Zone 1 is used if Input/Output Configuration is single phase, single zone, or three phase.

Zone 1 and 2 are used if Input/Output Configuration is single phase, two zones.

All zones are used if Input/Output Configuration is single phase, three zones.

<input type="checkbox"/> In	Input Signal Method Select (dig, mA, Volt) Select the input signal method for chosen zone.	<input type="checkbox"/> OFF off (0) <input type="checkbox"/> n n R current (1) <input type="checkbox"/> U o L T voltage (2) <input type="checkbox"/> d . 9 keyboard or comms (3)	<input type="checkbox"/> n n R current (1)	5101 r/w [1] 5201 r/w [2] 5301 r/w [3]	Active: Always. <input type="checkbox"/> d . 9 is not available if <input type="checkbox"/> SEt <input type="checkbox"/> R L 9 o in the Setup Page is set to <input type="checkbox"/> c o n t .
<input type="checkbox"/> d F L T	Default Numeric Input Signal (%) Selects the power-on level for chosen zone.	<input type="checkbox"/> 0 0 0 0 percent to <input type="checkbox"/> 1 0 0 0 100 percent (0 to 1000)	<input type="checkbox"/> 0 0 (0)	5103 r/w [1] 5203 r/w [2] 5303 r/w [3]	Active if input signal method is set to <input type="checkbox"/> d 1 9 .
<input type="checkbox"/> n n R _	Analog Input Low Current (mA) Sets current value which will correspond to 0% power if input is current type.	<input type="checkbox"/> 0 0 0 to <input type="checkbox"/> n n R _ [- 5mA] (0 to Analog Input High Current[-5mA])	<input type="checkbox"/> 0 0 0 (0)	5011 r/w [1] 5021 r/w [2] 5031 r/w [3]	Active if <input type="checkbox"/> In is set to <input type="checkbox"/> n n R current.
<input type="checkbox"/> n n R ~	Analog Input High Current (mA) Sets current value which will correspond to 100% power if input is current type.	<input type="checkbox"/> n n R _ [+ 5mA] to <input type="checkbox"/> 9 9 9 9 (Analog Input Low Current [+5mA] to 9999)	<input type="checkbox"/> 2 0 0 0 (2000)	5012 r/w [1] 5022 r/w [2] 5032 r/w [3]	Active if <input type="checkbox"/> In is set to <input type="checkbox"/> n n R current.
<input type="checkbox"/> U o L _	Analog Input Low Voltage (Volts) Sets voltage value which will correspond to 0% power if input is voltage type.	<input type="checkbox"/> 0 0 0 to <input type="checkbox"/> U o L ~ [- 2.5V] (0 to Analog Input High Voltage [-2.5V])	<input type="checkbox"/> 0 0 0 (0)	5013 r/w [1] 5023 r/w [2] 5033 r/w [3]	Active if <input type="checkbox"/> In is set to <input type="checkbox"/> U o L T voltage.

Display	Parameter	Range (Modbus Value)	Default	Modbus Register read/write	Conditions for Parameters to Appear
UoL	Analog Input High Voltage (Volts) Sets voltage value which will correspond to 100% power if input is voltage type.	UoL [+ 2.5V] to 9999 (Analog Input Low Voltage [+2.5V] to 9999)	1000 (1000)	5014 r/w [1] 5024 r/w [2] 5034 r/w [3]	Active if In is set to UoLE voltage.
Lrn .R	Learn Input Learn Request (Hi, Lo) Allows software to learn the high and low limits of the analog input signal.	Err invalid input signal (-1) idLE idle (0) LO low limit learn request (1) HI high limit learn request (2)	idLE idle (0)	5019 r/w [1] 5029 r/w [2] 5039 r/w [3]	Active if In is set to nonR current or UoLE voltage. Go to Lrn .R set analog input to low limit and set the controller to LO low limit. Wait 5 sec. for automatic input of low data for controller. The display will go back to idLE when done. Go to Lrn .R set the analog input to high limit and set the controller to HI high limit. Wait 5 sec. for automatic input of high data for controller. The display will go back to idLE when done.
bl U	Baseline Voltage Read/Adjust Shows the value for baseline voltage and allows manual adjustment of this value.	Minimum to maximum line voltage (minimum to maximum line voltage)	Line Voltage rating	5594 r/w [1] 5595 r/w [2] 5596 r/w [3]	Active: Always.
Lrn .U	Baseline Voltage Learn Request Allows software to learn the baseline voltage on line connected to the zone chosen.	Err invalid input signal (-1) idLE idle (0) rE9 learn request (1)	idLE idle (0)	5591 r/w [1] 5592 r/w [2] 5593 r/w [3]	Active: Always. Go to Lrn .U set the controller to rE9 . Wait 5 sec. for automatic input of data for controller. The display will go back to idLE when done.
TYPE	Load Type Select (Control Zone 1 only, 3 phase only.) Select the load type for Zone 1.	2L d 3 ph, 2-leg delta (0) 2L od 3 ph, 2-leg open delta (1) 2L uy 3 ph, 2-leg ungrounded wye (2) nonE unconfigured (3) 3L id 3 ph, 3-leg, 6 SCR inside delta (4) 3L d 3 ph, 3-leg, 6 SCR delta or ungrounded wye (5) 3L 99 3 ph, 3-leg, 6 SCR grounded wye (7)	nonE unconfigured (3)	58 r/w	Active if controller is a 3 phase system which only has one zone. NOTE: The parameters available are dependent on the controller's input/output configuration. The system does not operate unless this prompt is set to something other than nonE. NOTE: Changing this parameter will restart the system.

NOTE: For more information about how parameter settings affect the controller's operation, see Chapter Five, Control Methods and Features.

Display	Parameter	Range (Modbus Value)	Default	Modbus Address read/write	Conditions for Parameters to Appear
RALE	Maximum Rate of Change (%/100msec) Set maximum rate of power change of the power level for selected zone when input signal changes.	<input type="text" value="0.1"/> to <input type="text" value="100.0"/> 0.0 to 100.0% [.1% increments] (1 to 1000)	<input type="text" value="10.0"/> (100)	5104 r/w [1] 5204 r/w [2] 5304 r/w [3]	Active unless Input/Output configuration is 3 phase, 2-leg. Active if AL9o is set to Ph2L .
SOFT	Soft Start Time (Sec) Selects the time in seconds for the power level of the chosen zone to change from 0% to 100% when the power cycles.	<input type="text" value="0.0"/> to <input type="text" value="120.0"/> 0.0 to 120 seconds (.1 second increments) (0 to 1200)	<input type="text" value="4.0"/> (40)	5105 r/w [1] 5205 r/w [2] 5305 r/w [3]	Active unless Input/Output configuration is 3 phase, 2-leg. Active if AL9o is set to Ph2L .
RDLY	Reactance Delay for Transformer Loads Prevents half cycle errors and restarts on inductive loads. Increase value until half cycle errors no longer appear.	<input type="text" value="0.0"/> to <input type="text" value="50.0"/> (0 to 500)	<input type="text" value="0.0"/> (0)	5108 r/w	Active if AL9o is set to Ph2L and TYPE is set to 3Ld or 3Lld .

OPt1 OPt2 OPt3 Setup Options Zones 1, 2, and 3 Menus
SEt SEt SEt Setup Page

This menu is used to set up the options for the chosen zone. This set of menus is available only if Heater Diagnostics is installed.

Zone 1 is used if Input/Output Configuration is single phase, single zone, or three phase.

Zone 1 and Zone 2 are used if Input/Output configuration is single phase, two zones.

All zones are used if Input/Output Configuration is single phase, three zones.

Hbo	Heater Bakeout Select (On/Off) Select heater bakeout option for chosen zone.	<input type="text" value="OFF"/> off (0) <input type="text" value="On"/> selected (1)	<input type="text" value="OFF"/> off (0)	5110 r/w [1] 5210 r/w [2] 5310 r/w [3]	Active if heater diagnostics is installed. Active unless controller is 3 phase, 2 leg configuration.
PTIn	Heater Bakeout Select Time Selects the heater bakeout time in minutes for chosen zone.	<input type="text" value="0"/> to <input type="text" value="9999"/> 0 to 9999 minutes [1 minute increments] (0 to 9999)	1440 minutes (1440)	5111 r/w [1] 5211 r/w [2] 5311 r/w [3]	Active if heater diagnostics is installed. Active unless controller is 3 phase, 2 leg configuration. Active if Hbo is set to <input type="text" value="On"/> .
HbC	Heater Bakeout Over Current Trip Sets the maximum heater current during heater bakeout. Output will shut down at this value.	<input type="text" value="0"/> to <input type="text" value="Cur"/> 0 to Load Current Amps [1 Amp increment; maximum will be determined by Load Rating] (0 to Load Current Amps)	10.0% of load current	5116 r/w [1] 5216 r/w [2] 5316 r/w [3]	Active if heater diagnostics is installed. Active unless controller is 3 phase, 2 leg configuration. Active if Hbo is set to <input type="text" value="On"/> .

Display	Parameter	Range (Modbus Value)	Default	Modbus Address read/write	Conditions for Parameters to Appear
CL₁	Current Limit Select (On/Off) Selects current limit method for selected zone. Used in phase angle control only.	OFF off (0) On on (1)	OFF off (0)	5112 r/w [1] 5212 r/w [2] 5312 r/w [3]	Active if heater diagnostics is installed. Active unless controller is 3 phase, 2 leg configuration. Active if AL90 is set to Ph2L . NOTE: Changing this parameter will restart the system.
CL_A	Current Limit Set Point (A) Selects the current limit set point for current limiting in chosen zone.	0 to CL_{ur} 0 to Load Current Amps [1 Amp increment; maximum will be determined by Load Rating] (0 to Load Current Amps)	10.0% of load current	5113 r/w [1] 5213 r/w [2] 5313 r/w [3]	Active if heater diagnostics is installed. Active unless controller is 3 phase, 2 leg configuration. Active if AL90 is set to Ph2L and CL₁ is set to On . NOTE: Changing this parameter will restart the system.
LOL₋	Low Tolerance Set Point (A) Set heater tolerance low current set point for the selected zone. Value is current level for 100% requested power and is adjusted actual percentage of requested power.	0 to LOL₋ 0 amps to High Tolerance Set Point [1 amp increments] (0 to Heater High Tolerance Set Point)	0 (0)	5114 r/w [1] 5214 r/w [2] 5314 r/w [3]	Active if heater diagnostics is installed. This set point will only be used if the requested power is above 20%.
LOL₊	High Tolerance Set Point (A) Set heater tolerance high current set point for the selected zone. Value is current level for 100% full on.	LOL₋ to maximum system current [1 amp increments] (Heater Low Tolerance Set Point to max Load Current rating of the Power Series)	maximum system current	5115 r/w [1] 5215 r/w [2] 5315 r/w [3]	Active if heater diagnostics is installed. This set point will only be used if the requested power is above 20%.
IndF	Inductive Load Factor Request Requests an inductive load factor adjustment.	Err invalid request (-1) IDLE idle (0) rEQ request inductive load factor adjustment (1) Act active load factor adjustment (2) CLR clears factor (3)	IDLE idle (0)	5106 r/w [1] 5206 r/w [2] 5306 r/w [3]	Active if heater diagnostics is installed. Active unless Input/Output configuration is 3 phase, 2-leg. Active if AL90 is set to Ph2L . NOTE: Selecting Act or CLR will restart the system.
IC_{ur}	Inductive Current Sets the actual measured current for an inductive load.	0 to load current rating	Active load current	5107 r/w [1] 5207 r/w [2] 5307 r/w [3]	Active if heater diagnostics is installed. Active unless Input/Output configuration is 3 phase, 2-leg. Active if AL90 is set to Ph2L and IndF is set to rEQ .

NOTE: For more information about how parameter settings affect the controller's operation, see Chapter Five, Control Methods and Features.

Display	Parameter	Range (Modbus Value)	Default	Modbus Address read/write	Conditions for Parameters to Appear
<input type="checkbox"/> RLC	Setup Alarms Configuration Menu				
<input type="checkbox"/> SEE	Setup Page				
<i>This menu is used to set up the alarm configuration. For a definition of the alarm types — standard, latched, silenced, latched and silenced, see page 5.7.</i>					
<input type="checkbox"/> RL9c	Active Relay State Select the relay state on an alarm condition.	<input type="checkbox"/> RL C energized on alarm (0) <input type="checkbox"/> RL 0 de-energized on alarm (1)	<input type="checkbox"/> RL 0 de-energized on alarm (1)	850 r/w	Active: Always.
<input type="checkbox"/> 9LbL	Global Alarm Configuration Selects global alarm configuration. Configures all alarms to the same type or if set to OFF allows individual alarm configuration.	<input type="checkbox"/> SEd all alarms active (0) <input type="checkbox"/> LRE latched (1) <input type="checkbox"/> SIL silenced (2) <input type="checkbox"/> LRSI latched and silenced (3) <input type="checkbox"/> OFF off (4)	<input type="checkbox"/> SEd all alarms active (0)	851 r/w	Active: Always.
<input type="checkbox"/> OPEN	Heater Open Alarm Config. Select heater open alarm configuration.	<input type="checkbox"/> SEd active (0) <input type="checkbox"/> LRE latched (1) <input type="checkbox"/> SIL silenced (2) <input type="checkbox"/> LRSI latched and silenced (3)	<input type="checkbox"/> SEd active (0)	860 r/w	Active if heater diagnostics is installed. Active if 9LbL is set to OFF .
<input type="checkbox"/> tol	Heater Tolerance Alarm Config. Selects heater tolerance alarm configuration.	<input type="checkbox"/> SEd active (0) <input type="checkbox"/> LRE latched (1) <input type="checkbox"/> SIL silenced (2) <input type="checkbox"/> LRSI latched and silenced (3)	<input type="checkbox"/> SEd active (0)	861 r/w	Active if heater diagnostics is installed. Active if 9LbL is set to OFF .
<input type="checkbox"/> 0t	Heat Sink Over Temperature Alarm Config. Select over temperature alarm configuration.	<input type="checkbox"/> SEd active (0) <input type="checkbox"/> LRE latched (1) <input type="checkbox"/> SIL silenced (2) <input type="checkbox"/> LRSI latched and silenced (3)	<input type="checkbox"/> SEd active (0)	862 r/w	Active if 9LbL is set to OFF .
<input type="checkbox"/> RLT	Heat Sink Over Temperature Alarm Temperature Select heat sink overtemp alarm configuration.	<input type="checkbox"/> 0 to <input type="checkbox"/> SdT	Value equal to <input type="checkbox"/> SdT or less. User adjustable. See Factory Menu for actual safety shutdown temp.	990 r/w	Active: Always. Output will de-energize at this heatsink shut down temperature (degrees C). The default maximum temperature is model number dependent.
<input type="checkbox"/> L0E	Line Loss Alarm Configuration Selects the line loss alarm configuration.	<input type="checkbox"/> SEd active (0) <input type="checkbox"/> LRE latched (1) <input type="checkbox"/> SIL silenced (2) <input type="checkbox"/> LRSI latched and silenced (3)	<input type="checkbox"/> SEd active (0)	863 r/w	Active if 9LbL is set to OFF .

Display	Parameter	Range (Modbus Value)	Default	Modbus Address read/write	Conditions for Parameters to Appear
P.bAL	Phase Balance Alarm Config. Select phase balance configuration.	SEd active (0) LAE latched (1) SIL silenced (2) LAS1 latched and silenced (3)	SEd active (0)	864 r/w	Active if controller is 3 phase, 3-leg configuration. Active if 9LbL is set to OFF .
LbAL	Load Balance Alarm Config. Selects the load balance alarm configuration.	SEd active (0) LAE latched (1) SIL silenced (2) LAS1 latched and silenced (3)	SEd active (0)	865 r/w	Active if heater diagnostics is installed. Active if 9LbL is set to OFF . Active if controller is 3 phase.
Ld.F	Load Balance Percentage Selects the minimum percentage difference between loads current in phases.	0 to 100 (0 to 100)	100 (100)	991 r/w	Active if heater diagnostics is installed. Active if controller is 3 phase.
FrEQ	Frequency Out of Tolerance Alarm Configuration Select frequency tolerance alarm configuration.	SEd active (0) LAE latched (1) SIL silenced (2) LAS1 latched and silenced (3)	SEd active (0)	866 r/w	Active if 9LbL is set to OFF .
UC	Voltage Compensation Alarm Config. Selects the line compensation alarm configuration.	SEd active (0) LAE latched (1) SIL silenced (2) LAS1 latched and silenced (3)	SEd active (0)	867 r/w	Active if 9LbL is set to OFF .
OU	Over Voltage Alarm Config. Selects the line over-voltage alarm configuration.	SEd active (0) LAE latched (1) SIL silenced (2) LAS1 latched and silenced (3)	SEd active (0)	868 r/w	Active if 9LbL is set to OFF .
C.Wd	Comms Watchdog Alarm Config. Selects the communications watchdog alarm configuration.	SEd active (0) LAE latched (1) SIL silenced (2) LAS1 latched and silenced (3)	SEd active (0)	869 r/w	Active if communications is installed. Active if 9LbL is set to OFF .

NOTE: For more information about how parameter settings affect the controller's operation, see Chapter Five, Control Methods and Features.

Display	Parameter	Range (Modbus Value)	Default	Modbus Register read/write	Conditions for Parameters to Appear
---------	-----------	-------------------------	---------	----------------------------------	--

[COP7] Setup Comms Configuration Menu

[SEt] Setup Page

This menu is used to set up the communications parameters. This menu is not available unless Serial Communications is installed.

[Addr] Unit Address Select Select device address for communications.	<input type="text" value="1"/> to <input type="text" value="247"/>	<input type="text" value="1"/>			Active if serial communications option is installed.
[bAud] Unit Baud Rate Select Select baud rate for communications.	<input type="text" value="1200"/> 1200 baud <input type="text" value="2400"/> 2400 baud <input type="text" value="4800"/> 4800 baud <input type="text" value="9600"/> 9600 baud <input type="text" value="19.2"/> 19.2K baud	<input type="text" value="9600"/> 9600 baud			Active if serial communications option is installed.
[Wd] Watchdog Select (On/Off) Turns on a watchdog for communications.	<input type="text" value="OFF"/> off (0) <input type="text" value="On"/> on (1)	<input type="text" value="OFF"/> off (0)	85 r/w		Active if serial communications option is installed.
[SEC] Watchdog Timeout (Sec) Selects a timeout in seconds for the communications watchdog.	<input type="text" value="0"/> to <input type="text" value="9999"/> (0 to 9999)	<input type="text" value="9999"/> (9999)	86 r/w		Active if serial communications option is installed and <input type="text" value="Wd"/> Watchdog is set to <input type="text" value="On"/> .
[PbW] Watchdog Failure Output Power Select Selects the default power level for a watchdog timeout.	<input type="text" value="00"/> 0 percent to <input type="text" value="1000"/> 100 percent (0 to 1000)	<input type="text" value="00"/> 0 percent (0)	87 r/w		Active if serial communications option is installed and <input type="text" value="Wd"/> Watchdog is set to <input type="text" value="On"/> .

[REtR] Setup Retransmit Configuration Menu

[SEt] Setup Page

This menu is used to set up the retransmit parameters. The menu is not available unless Retransmit and Heater Diagnostics are installed.

[CF9] Retransmit Config. Select Select type of retransmit output.	<input type="text" value="mA"/> mA (0) <input type="text" value="VOLT"/> volts (1)	<input type="text" value="mA"/> mA (0)	870 r/w		Active if retransmit and heater diagnostics options are installed.
[TYPE] Retransmit Type Select Select type of retransmit information; amps or kVA.	<input type="text" value="OFF"/> none (0) <input type="text" value="CUR"/> current (1) <input type="text" value="HVA"/> kVA (2)	<input type="text" value="CUR"/> current (1)	871 r/w		Active if retransmit and heater diagnostics options are installed.

Display	Parameter	Range (Modbus Value)	Default	Modbus Register read/write	Conditions for Parameters to Appear
PHAS	Retransmit Phase Select Select the phase with information to be retransmitted.	<input type="text" value="1"/> phase 1 (1) <input type="text" value="2"/> phase 2 (2) <input type="text" value="3"/> phase 3 (3)	<input type="text" value="1"/> phase 1 (1)	872 r/w	Active if retransmit and heater diagnostics options are installed. Active if controller is three phase. Active if RETR ► TYPE is set to CUR or HUR .
ZONE	Retransmit Zone Select Select the zone with information to be retransmitted.	<input type="text" value="1"/> zone1 (1) <input type="text" value="2"/> zone2 (2) <input type="text" value="3"/> zone3 (3)	<input type="text" value="1"/> zone1 (1)	873 r/w	Active if retransmit and heater diagnostics options are installed. Active if controller is multi zone. Active if RETR ► TYPE is set to CUR or HUR .
CUR_{min}	Minimum Amps Retransmit Select minimum load current to be retransmitted.	<input type="text" value="0"/> to CUR_{max} (0 to Maximum Amps Retransmit)	<input type="text" value="00"/> (0)	876 r/w	Active if retransmit and heater diagnostics options are installed. Active if RETR ► TYPE is set to CUR .
CUR_{max}	Maximum Amps Retransmit Select maximum load current to be retransmitted.	CUR_{min} to load current (Minimum Amps Retransmit to load current)	load current	877 r/w	Active if retransmit and heater diagnostics options are installed. Active if RETR ► TYPE is set to CUR .
HUR_{min}	Minimum kVA Retransmit Select minimum load power to be retransmitted.	<input type="text" value="0"/> to HUR_{max} (0 to Maximum kVA Retransmit)	<input type="text" value="0"/> (0)	878 r/w	Active if retransmit and heater diagnostics options are installed. Active if RETR ► TYPE is set to HUR .
HUR_{max}	Maximum kVA Retransmit Select maximum load power to be retransmitted.	HUR_{min} to 9999 (Minimum kVA Retransmit to 9999)	9999 (9999)	879 r/w	Active if retransmit and heater diagnostics options are installed. Active if RETR ► TYPE is set to HUR .
RE_C_{min}	Retransmit Output Low Current (mA) Select output current that will correspond to CUR_{min} or HUR_{min} .	<input type="text" value="000"/> to RE_C_{max} (0 to Retransmit Output High Current)	<input type="text" value="0"/> (0)	882 r/w	Active if retransmit and heater diagnostics options are installed. Active if CFG is set to ONB .
RE_C_{max}	Retransmit Output High Current (mA) Select output current that will correspond to CUR_{max} or HUR_{max} .	RE_C_{min} to 2000 (Retransmit Output Low Current to 2000)	2000 (2000)	883 r/w	Active if retransmit and heater diagnostics options are installed. Active if CFG is set to ONB .

NOTE: For more information about how parameter settings affect the controller's operation, see Chapter Five, Control Methods and Features.

Display	Parameter	Range	Default	Modbus Address read/write	Conditions for Parameters to Appear
rt.U	Retransmit Output Low Voltage (Volts) Select voltage that will correspond to Cur or HUR .	0.00 to rt.U (0 to Retransmit Output High Voltage)	0 (0)	880 r/w	Active if retransmit and heater diagnostics options are installed. Active if CF9 is set to UoLt .
rt.U	Retransmit Output High Voltage (Volts) Select voltage that will correspond to Cur or HUR .	rt.U to 10.00 (Retransmit Output Low Voltage to 1000)	10.00 (1000)	881 r/w	Active if retransmit and heater diagnostics options are installed. Active if CF9 is set to UoLt .

Factory Page

To enter the Factory Page, press the Home, Left and Right keys (**■** **◀** **▶**) together while in the Setup Page. Each of the following menus in the Factory Page are selected by pressing the Increment/Decrement keys (**▲** **▼**). Each press of the button will scroll you up or down through these main menu options.

To select a parameter within a menu, use the Left/Right arrow keys (**◀** **▶**). The parameter appears in the bottom display.

To select a value for each parameter (either alpha or numeric), use the Increment/Decrement keys (**▲** **▼**). The value appears in the upper display.

Pressing the Home key (**■**) in this menu will return you to the Display Loop.

The Factory Page contains nine menus.

The Factory Mode parameters of the Factory Page are used for calibration of the Power Series. Since the Power Series is precalibrated at the factory; field calibration may only be necessary in the event that field service work is performed. Field calibration procedures are available at Watlow's website, <http://www.watlow.com/>.

***NOTE: To enter the Factory Mode requires a password. Call Watlow at +1 (507) 454-5300, and ask an applications engineer for this password. Once the password is entered, the controller is in Factory Mode. The controller's power must be cycled to exit the Factory Mode.**

FcTy Factory Page	dAtA System Data Manipulation
Go to a factory menu.	Loc Global/Menu Lockouts
	InfO Unit Information
	d,Ag Diagnostics
Factory Mode ->	PwD Factory Password
Requires factory password to access calibration parameters.	Cal1 Calibrate Analog Input Signal Zone 1*
	Cal2 Calibrate Analog Input Signal Zone 2*
	Cal3 Calibrate Analog Input Signal Zone 3*
	Calr Calibrate Retransmit*

Display	Parameter	Range (Modbus Value)	Default	Modbus Address read/write	Conditions for Parameters to Appear
dRtA <i>System Data Manipulation Menu</i>					
FctY <i>Factory Page</i>					
<i>This menu is used to maintain the standard and backup system data.</i>					
bRUP	Backup Data Set* Stores appropriate user configurable parameters into backup memory. See page A.7 for Power Series Backup information.	<input type="checkbox"/> dLE no backup requested (0) <input type="checkbox"/> ALL all parameters listed in system, zone 1, 2 and 3 (1) <input type="checkbox"/> 555 system related parameters, includes locks, alarms, retransmit, comms, algorithm, load type, voltage compensation (2) <input type="checkbox"/> 2n 1 zone 1 related parameters, includes all parameters in menus Cr 1 and OPt 1 (3) <input type="checkbox"/> 2n 2 zone 2 related parameters, includes all parameters in menus Cr 2 and OPt 2 (4) <input type="checkbox"/> 2n 3 zone 3 related parameters, includes all parameters in menus Cr 3 and OPt 3 (5)	<input type="checkbox"/> dLE no backup requested (0)	951 r/w	Active: Always.
dFLt	Default Data Set* Sets the appropriate parameters to the factory default values. See page A.7 for Power Series Backup information.	<input type="checkbox"/> dLE (0) <input type="checkbox"/> ALL (1) <input type="checkbox"/> 555 (2) <input type="checkbox"/> 2n 1 (3) <input type="checkbox"/> 2n 2 (4) <input type="checkbox"/> 2n 3 (5) NOTE: See "Backup Data Set" above for description of the Modbus values 0 - 5.	<input type="checkbox"/> dLE disable restore (0)	952 r/w	Active: Always.
rESE	Restore Data Set* Restores the appropriate user configurable parameters from backup memory. See page A.7 for Power Series Backup information.	<input type="checkbox"/> dLE (0) <input type="checkbox"/> ALL (1) <input type="checkbox"/> 555 (2) <input type="checkbox"/> 2n 1 (3) <input type="checkbox"/> 2n 2 (4) <input type="checkbox"/> 2n 3 (5) NOTE: See "Backup Data Set" above for description of the Modbus values 0 - 5.	<input type="checkbox"/> dLE disable restore (0)	950 r/w	Active: Always.

*NOTE: These prompts (Backup, Default, and Restore Data Set) allow the user to manipulate the EEPROM contents. See Appendix, p. A.7, for more information.

Display	Parameter	Range (Modbus Value)	Default	Modbus Address read/write	Conditions for Parameters to Appear
nVOL	Enable NVOL Storage Enable/disable non-volatile memory.	<input type="checkbox"/> On enable (0) <input type="checkbox"/> OFF disable (1)	<input type="checkbox"/> On (0)	959 r/w	Active: Always.

L0C *Global/Menu Lockouts Menu*
FctY *Factory Page*

This menu is used to set the lockout parameters. Locked means that the parameters in the menu cannot be changed.

9LOC	Global Lockout Sets the state of global lockout which allows all prompts to be write protected. If set to unlocked, individual menu locks can be set.	<input type="checkbox"/> UnL Unlocked (0) <input type="checkbox"/> L0C Locked (1)	<input type="checkbox"/> UnL (0)	1350 r/w	Active: Always.
CEr	Control Setup Menus Lockout Sets lock on all control setup menus.	<input type="checkbox"/> UnL Unlocked (0) <input type="checkbox"/> L0C Locked (1)	<input type="checkbox"/> UnL (0)	1351 r/w	Active if 9LOC is set to <input type="checkbox"/> UnL .
OPt	Options Setup Menus Lockout Sets lock on all options setup menus.	<input type="checkbox"/> UnL Unlocked (0) <input type="checkbox"/> L0C Locked (1)	<input type="checkbox"/> UnL (0)	1352 r/w	Active if 9LOC is set to <input type="checkbox"/> UnL . Active if heater diagnostics option is installed.
ALr	Alarms Setup Menu Lockout Sets lock on alarm configuration menu.	<input type="checkbox"/> UnL Unlocked (0) <input type="checkbox"/> L0C Locked (1)	<input type="checkbox"/> UnL (0)	1353 r/w	Active if 9LOC is set to <input type="checkbox"/> UnL .
COPT	Comms Setup Menu Lockout Sets lock on communications menu.	<input type="checkbox"/> UnL Unlocked (0) <input type="checkbox"/> L0C Locked (1)	<input type="checkbox"/> UnL (0)	1354 r/w	Active if 9LOC is set to <input type="checkbox"/> UnL . Active if serial communications option is installed.
REtr	Retransmit Setup Menu Lockout Sets lock on retransmit menu.	<input type="checkbox"/> UnL Unlocked (0) <input type="checkbox"/> L0C Locked (1)	<input type="checkbox"/> UnL (0)	1355 r/w	Active if 9LOC is set to <input type="checkbox"/> UnL . Active if retransmit and heater diagnostics options are installed.
CI n	Analog Input Factory Menus Lockout Sets lock on input calibration menu.	<input type="checkbox"/> UnL Unlocked (0) <input type="checkbox"/> L0C Locked (1)	<input type="checkbox"/> UnL (0)	1356 r/w	Active if 9LOC is set to <input type="checkbox"/> UnL .
CEtr	Retransmit Cal Factory Menu Lockout Sets lock on retransmit calibration menu.	<input type="checkbox"/> UnL Unlocked (0) <input type="checkbox"/> L0C Locked (1)	<input type="checkbox"/> UnL (0)	1357 r/w	Active if 9LOC is set to <input type="checkbox"/> UnL . Active if retransmit and heater diagnostics options are installed.

Display	Parameter	Range (Modbus Value)	Default	Modbus Address read/write	Conditions for Parameters to Appear
DATA	System Data Factory Menu Lockout Sets lock on system data menu.	<input type="checkbox"/> UnL Unlocked (0) <input type="checkbox"/> LOC Locked (1)	<input type="checkbox"/> UnL (0)	1358 r/w	Active if 9LOC is set to <input type="checkbox"/> UnL .
DIAG	Diagnostics Facto- ry Menu Lockout Sets lock on diagnos- tics menu.	<input type="checkbox"/> UnL Unlocked (0) <input type="checkbox"/> LOC Locked (1)	<input type="checkbox"/> UnL (0)	1359 r/w	Active if 9LOC is set to <input type="checkbox"/> UnL .

INFO *Unit Information Menu*

FACTY *Factory Page*

This menu is used to read unit information that is stored during manufacture.

Snr	Unit Serial Num- ber High Digits Reads the high digits of the serial number of the unit.	<input type="text"/> 0 to <input type="text"/> 9999 (0 to 9999)	n/a	1 r	Active: Always.
Snl	Unit Serial Num- ber Low Digits Reads the low digits of the serial number of the unit.	<input type="text"/> 0 to <input type="text"/> 9999 (0 to 9999)	n/a	2 r	Active: Always.
DATE	Manufactured Date (yymm) Reads month and year of manufacture.	<input type="text"/> 00 to <input type="text"/> 99 year (00 to 99) <input type="text"/> 00 to <input type="text"/> 99 month (00 to 52)	n/a	5 r	Active: Always.
HVER	Hardware Version Reads hardware ver- sion of the unit.	<input type="text"/> 00 to <input type="text"/> 9999 (0 to 9999)	n/a	7 r	Active: Always.
SVER	Software Version Reads software ver- sion of the unit.	<input type="text"/> 00 to <input type="text"/> 9999 (0 to 9999)	n/a	4 r	Active: Always.
SBLD	Software Build Number Reads software build level of the unit.	<input type="text"/> 00 to <input type="text"/> 9999 (0 to 9999)	n/a	30 r	Active: Always.
RRTU	Unit Voltage Rating (Volts) Reads load voltage of the unit.	<input type="text"/> 0 to <input type="text"/> 680 (0 to 680)	n/a	51 r	Active: Always.

NOTE: For more information about how parameter settings affect the controller's operation, see Chapter Five, Control Methods and Features.

Display	Parameter	Range (Modbus Value)	Default	Modbus Address read/write	Conditions for Parameters to Appear
rALr	Unit Current Rating (Amps) Reads load current of the unit.	<input type="text" value="0"/> to <input type="text" value="245"/> (0 to 245)	n/a	50 r	Active: Always.
2onC	Number Zones Configured Reads the number of zones that are configured.	<input type="text" value="1"/> single zone (1) <input type="text" value="2"/> two zone (2) <input type="text" value="3"/> three zone (3)	n/a	52 r	Active: Always.
OPt	Configuration Installed Options Reads the configuration of the hardware options.	<input type="text" value="none"/> none (0) <input type="text" value="c"/> comms (1) <input type="text" value="r"/> retransmit (2) <input type="text" value="rc"/> comms/retransmit (3) <input type="text" value="h"/> heater diagnostics (4) <input type="text" value="hc"/> heater diagnostics/comms (5) <input type="text" value="hr"/> heater diagnostics/retransmit (6) <input type="text" value="hrc"/> heater diagnostics/comms/retransmit 2 (7)	n/a	54 r	Active: Always.
<input type="text" value="C"/>	Heat Sink Temp (°C) Reads the current heat sink temp.	<input type="text" value="0"/> to <input type="text" value="9999"/> (0 to 9999)	n/a	1590 r	Active: Always.
ALC	Heat Sink Alarm Temp Set the set point for the heat sink over temp alarm.	<input type="text" value="0"/> to <input type="text" value="5dC"/>	n/a	990 r/w	Active: Always. Same as alarm temp in Setup Menu.
5dC	Factory Safety Shutdown Temp Indicates set point for factory safety shutdown.	Factory set.	n/a	57 r	Active: Always.
HIC	Record High Heat Sink Temp Indicates record high heat sink temp.	<input type="text" value="0"/> to <input type="text" value="9999"/> (0 to 9999)	n/a	1591 r	Active: Always.
HrS	Accum Hours (10K - 100M) Indicates accumulated system operating time (hours x 10000).	<input type="text" value="0"/> to <input type="text" value="9999"/> (0 to 9999)	n/a	1960 r	Active: Always. Masked if hours <10000
HrS	Accum Hours (0 - 9999) Accumulated system operating time (hours).	<input type="text" value="0"/> to <input type="text" value="9999"/> (0 to 9999)	n/a	1961 r	Active: Always.

Display	Parameter	Range (Modbus Value)	Default	Modbus Address read/write	Conditions for Parameters to Appear
d .R9 <i>Diagnostics Menu</i>					
Fct4 <i>Factory Page</i>					
<i>This menu is to select diagnostics.</i>					
Ad	Select A/D Channel Selects an analog to digital channel to read.	UrEe voltage reference input* Er7P heat sink temp input* RIn1 analog input 1* RIn2 analog input 2* RIn3 analog input 3* UoL1 voltage input1* UoL2 voltage input2* UoL3 voltage input3* Cur1 positive current input 1* Cur2 positive current input 2* Cur3 positive current input 3* Cur1 negative current input 1* Cur2 negative current input 2* Cur3 negative current input 3* * Values 0 to 4095		1560 r 1561 r 1562 r 1563 r 1564 r 1565 r 1566 r 1567 r 1568 r 1569 r 1570 r 1571 r 1572 r 1573 r	Active: Always.
Cnt5	Read Selected A/D Counts Reads the selected analog to digital channel.	0 to 4095	n/a	n/a	Active: Always.
Line Loss Alarms: The following nine parameters indicate line loss alarms that have occurred since power was last cycled. The parameters will only appear if there has been a line loss alarm and only for the line/s on which a line loss alarm has occurred. They will continue to appear until power is cycled again.					
L_R1	Most Recent Line Loss Alarm Type	none (0) no recorded alarms uUoL (1) under voltage	none (0)	1540 r 1543 r 1546 r	Active for line on which line loss alarm has occurred since power cycle.
L_R2	Previous Line Loss Alarm Type	R.Cr (2) extra zero cross n.Cr (4) no zero cross		1541 r 1544 r 1547 r	
L_R3	Least Recent Line Loss Alarm Type	PoL (8) invalid line polarity n.Cr (16) no zero cross FrE9 (32) invalid frequency		1542 r 1545 r 1548 r	
L_	indicates which phase 1, 2 or 3 experienced the alarm	HcYc (64) load half cycle loss			

NOTE: For more information about how parameter settings affect the controller's operation, see Chapter Five, Control Methods and Features.

Display	Parameter	Range (Modbus Value)	Default	Modbus Address read/write	Conditions for Parameters to Appear
dISP	Display Test Requests a display test.	idle (0) enable display test (1)	idle (0)	1513 r/w	Active: Always.
in	Select Discrete Input Requests a display of the state of the chosen input.	none (0) POS1 (1) POS2 (2) POS3 (3) OCR1 (4) OCR2 (5) OCR3 (6)	none (0)	1580 r/w	Active: Always. Factory mode only for write.
URL	Read Selected Input Value	lo (0) hi (1) undeterminate (2)	----	1581 r	Active if in is not set to none .
REtc	Retransmit Set Test Word Sets retransmit test count.	0 to 4095 (0 to 4095)	0 (0)	1555 r/w	Active if retransmit option is installed. Factory mode only for write.

Factory Mode

The Factory Mode parameters of the Factory Page are used for calibration of the Power Series. Since the Power Series is precalibrated at the factory, field calibration may only be necessary in the event that field service work is performed. Field calibration procedures are available at Watlow's website, <http://www.watlow.com/>.

NOTE: To enter the Factory Mode requires a password. Call Watlow at +1 (507) 454-5300, and ask an applications engineer for this password. Once the password is entered, the controller is in Factory Mode. The controller's power must be cycled to exit the Factory Mode.

PLJ *Factory Password*
FctY *Factory Page*

This menu is used to set the password for the Power Series' Factory Mode.

PLJ	Factory Password Entry Enter factory password.	0 to 9999 (0 to 9999)	1234	1799 r/w	Active: Always.
FctY	Factory Mode Request Requests factory mode based on value set in Factory Password prompt.	OFF idle (0) request factory mode (1) factory mode active (2)	OFF idle (0)	1700 r/w	Active if factory password is valid.

Display	Parameter	Range (Modbus Value)	Default	Modbus Address read/write	Conditions for Parameters to Appear
---------	-----------	-------------------------	---------	---------------------------------	--

[In1] [In2] [In3] Calibrate Analog Input Signal Zones 1, 2, and 3 Menus
[FctY] [FctY] [FctY] Factory Page

This menu is used to set up the analog inputs.

Input 1 is used if Input/Output Configuration is single phase, single zone or three phase.

Input 1 and Input 2 are used if Input/Output Configuration is single phase, two zones.

All zones are used if Input/Output Configuration is single phase, three zones.

NOTE: Care should be taken to allow a buffer between each of the settings and their respective hardware limits to prevent unexpected operation because of noise or signal variations.

[nnR_] Low mA Cal Point Sets the low current value for the corresponding analog input calibration.	[0000] to [nnR_] [or [9999] whichever is smaller] (0 to High mA Cal Point [or 9999])	[4000] (4000)	5411 r/w [1] 5421 r/w [2] 5431 r/w [3]	Active if in factory mode.
[nnR_] High mA Cal Point Sets the high current value for the corresponding analog input calibration.	[nnR_] to [2000] (Low mA Cal Point to 20000)*	[1600] (16000)	5412 r/w [1] 5422 r/w [2] 5432 r/w [3]	Active if in factory mode.

***NOTE: The display prompts are set to two decimal places because of the resolution of the display. The comms registers are set and stored with three decimal places of resolution.**

[UoL_] Low V Cal Point Sets the low voltage value for the corresponding analog input calibration.	[0000] to [UoL_] (0 to High V Cal Point)	[1000] (1000)	5413 r/w [1] 5423 r/w [2] 5433 r/w [3]	Active if in factory mode.
[UoL_] High V Cal Point Sets the high voltage value for the corresponding analog input calibration.	[UoL_] to [9999] (Low V Cal Point to 9999)	[9000] (9000)	5414 r/w [1] 5424 r/w [2] 5434 r/w [3]	Active if in factory mode.
[CALR] Calibrate Analog Input Request Request analog input signal calibration.	[Err] invalid calibration (-1) [idle] calibration inactive (0) [rEg] enables calibration request (1)	[idle] calibration inactive (0)	5415 r/w [1] 5425 r/w [2] 5435 r/w [3]	Active if in factory mode.

✓ **NOTE: The values entered in the preceding prompts are used with the corresponding analog to digital counts. The parameter [Err] will be displayed if the calibrations fails; otherwise the parameter will return to [idle].**

NOTE: For more information about how parameter settings affect the controller's operation, see Chapter Five, Features.

Display	Parameter	Range (Modbus Value)	Default	Modbus Address read/write	Conditions for Parameters to Appear
[r t r] Calibrate Retransmit Menu					
[F c t y] Factory Page					
<i>This menu is used to calibrate the retransmit output. This menu is available if Retransmit is installed.</i>					
[n n R _]	Retransmit Cal mA Low Selects the low current value for retransmit cal.	[0.000] to [n n R _] [or [9.999] whichever is smaller] (0 to Retransmit Cal mA High [or 9999])	[4.000] (4000)	5710 r/w	Active if in factory mode. Active if retransmit option is installed.
[n n R ^]	Retransmit Cal mA High Set the high current value for retransmit cal.	[n n R _] to [20.00] (Retransmit Cal mA Low to 20000)*	[16.00] (16000)	5711 r/w	Active if in factory mode. Active if retransmit option is installed.
[U o L _]	Retransmit Cal Volts Low Set the low voltage value for retransmit cal.	[0] to [U o L ^] (0 to Retransmit Cal Volts High)	[1.000] (1000)	5720 r/w	Active if in factory mode. Active if retransmit option is installed.
[U o L ^]	Retransmit Cal Volts High Set the high voltage value for retransmit cal.	[U o L _] to [9.999] (Retransmit Cal Volts Low to 9999)	[9.000] (9000)	5721 r/w	Active if in factory mode. Active if retransmit option is installed.
[C A L r]	Cal Retransmit Request Request a retransmit calibration.	[E r r] invalid calibra- tion (-1) [i d L E] calibration inactive (0) [r E 9] enables cali- bration request (1)	[i d L E] cali- bration inactive (0)	5700 r/w	Active if in factory mode. Active if retransmit option is installed.

***NOTE:** The display prompts are set to two decimal places because of the resolution of the display. The comms registers are set and stored with three decimal places of resolution.

NOTE: For more information about how parameter settings affect the controller's operation, see Chapter Five, Features.

A

Appendix



Troubleshooting	A.2
Troubleshooting Alarms and Errors	A.4
Checking and Replacing Fuses	A.6
Power Series Backup	A.7
Modbus Registration Numbers	A.8
Product Specification	A.9
Ordering Information	A.10
Index	A.11
Prompt Index	A.13
CE Declaration of Conformity	A.14
Warranty Information	back cover

Troubleshooting

All Units

Indication	Probable Cause	Corrective Action
No LED Display	<ul style="list-style-type: none"> • Controller power not present. • Display not seated properly. • Bent or broken pins. • Faulty (malfunctioning) unit. 	<ul style="list-style-type: none"> • Insure that the unit is plugged in and the power is on. • Check the display to make sure it is flush with plastic. • Pull off the display and check the connection pins; repair or replace if necessary. • Return the unit to the factory for repair.
Display Locked	<ul style="list-style-type: none"> • System error. • System error (no problem found). • System error not displayed. • Alarm. • Alarm (no problem found). 	<ul style="list-style-type: none"> • Record error and address the cause of the error. • Record error and cycle controller power. If the problem persists, contact factory for assistance. • Cycle controller power. If the problem persists, contact factory for assistance or return the unit to the factory for repair. • Record alarm and address the cause of the alarm. • Record alarm and cycle controller power. If the problem persists, contact the factory for assistance.
No Heat	<ul style="list-style-type: none"> • Heater or load wire is not connected. • Blown fuse. • SEt > ALGo is set to OFF. • Incorrect input wiring. • Line not connected or off, or the voltage is too low. Controller will indicate ALr (Line Loss Alarm) LinE. • Internal malfunction (core PCB, open SCR, gate drive inoperative, core to power supply and LM connection, power supply and line monitor PCB not seated properly on SCR). 	<ul style="list-style-type: none"> • Check the load or load wire; connect if necessary. • Check the fuses and replace any if necessary. • See page 6.5 to set power control algorithm. • Check the input wiring and ensure that it is connected properly. (See pages 3.2-3.3 for wiring.) Input can be monitored with in parameter in the Display Loop. With keyboard control, test by increasing output by % and checking for heat. Be careful to not over heat anything. • Insure that line power is connected and is on at the appropriate voltage. • Return the unit to the factory for repair.
Partial Heat	<ul style="list-style-type: none"> • Line input voltage low. 	<ul style="list-style-type: none"> • Insure that line power is connected and is on at the appropriate voltage. • Return the unit to the factory for repair.
Full or Partial Uncontrollable Heat	<ul style="list-style-type: none"> • Shorted SCR. • Input out of calibration. • Internal malfunction. 	<ul style="list-style-type: none"> • If the controller has heater diagnostics installed, a shorted SCR will cause an error and shut down the remaining good SCRs. Return the unit to the factory for repair. If the controller does not have heater diagnostics installed, if output power (%) Out reads 00 and there is power to the heater, the SCR is shorted; return the unit to the factory for repair. • With input signal set for 0% power, check output power display; if it is not 00, check calibration. With input signal set for 100% power, check output power display; if it is not 1000, check calibration. • Return the unit to the factory for repair.

All Units (continued)

Indication	Probable Cause	Corrective Action
Frequent Nuisance Fuse Blowing	<ul style="list-style-type: none"> Improper fuse current rating. Fuses improperly torqued. Inadequate ventilation or cooling in the cabinet. Intermittent short in heater. 	<ul style="list-style-type: none"> Refer to page 2.1; insure the fuses have the correct current rating. Refer to page A.6 for guidelines on proper torquing of fuses. Refer to page 2.3 for enclosure guidelines and how to determine how much cooling is required. Replace heater.

Single Phase Units

Indication	Probable Cause	Corrective Action
No Heat	<ul style="list-style-type: none"> Power not routed through the internal bussbar. Controller will indicate ALr (Line Loss Alarm) LinE. 	<ul style="list-style-type: none"> If power is not routed through or connected to the internal bussbar, Ref. 2 must be connected to another line or to neutral. (See page 3.4 for wiring.)

Multizone Units

Indication	Probable Cause	Corrective Action
No Heat	<ul style="list-style-type: none"> Reference not connected. 	<ul style="list-style-type: none"> Reference connections to other lines or neutral must be made appropriately for each zone. (See page 3.5 for wiring.)
No current monitor on the display.	<ul style="list-style-type: none"> Two phases are 180° out of phase of each other. 	<ul style="list-style-type: none"> When using the multizone feature, the 2 or 3 zones should be wired so that no two phases are 180° out of phase. See wiring diagram page 3.5, Figure 3.5C.

3 Phase, 2-Leg Units

Indication	Probable Cause	Corrective Action
No Heat	<ul style="list-style-type: none"> Power not routed through the internal bussbar. Controller will indicate ALr (Line Loss Alarm) LinE. Load Type Select EYPE for 3 phase is set to unconfigured nonE. 	<ul style="list-style-type: none"> If power is not routed through or connected to the internal bussbar, Ref. 1 or 3 (not both) must be connected to middle line. (See page 3.4 for wiring.) In the Setup Page, Setup Control Zone 1 menu, select the load type for Zone 1.

3 Phase, 3-Leg Units

Indication	Probable Cause	Corrective Action
No Heat	<ul style="list-style-type: none"> Reference is not connected for 3 phase, 3-leg grounded wye unit. Load Type Select EYPE for 3 phase is set to unconfigured nonE. 	<ul style="list-style-type: none"> For 3 phase, 3 grounded wye models only, reference connections must be connected to neutral. (See page 3.5 for wiring.) In the Setup Page, Setup Control Zone 1 menu, select the load type for Zone 1.
Phase angle control ramps output power up, develops a hCYL error and shuts down	<ul style="list-style-type: none"> Inductive load causing half cycle line loss errors hCYL. Reactance delay rDLy is set too low. 	<ul style="list-style-type: none"> Increase rDLy value until the half cycle line loss errors no longer occur.

Troubleshooting Alarms and Errors

Alarm / Error	Condition For Alarm or Error To Occur
<input type="checkbox"/> ALr <input type="checkbox"/> OPEn Heater Open Alarm	Alarm will occur when ≤ 2 amps is detected (as measured by the Power Series) for $> 20\%$ requested power.
<input type="checkbox"/> ALr <input type="checkbox"/> LoL Heater Tolerance Alarm	Alarm will occur when the load current detected is less than the value set in the Setup Page $>$ Options Menu $>$ LoL₋ or is greater than the value set in LoL₊ . This will accomplish both the overcurrent condition alarm and the heater failure low current alarm. This will only occur if requested power is greater than 20 percent.
<input type="checkbox"/> ALr <input type="checkbox"/> OE Heat Sink Over Temperature Alarm	Alarm will occur when the heat sink temperature is greater than the value set in the Setup Page $>$ ALr $>$ ALC .
<input type="checkbox"/> ALr <input type="checkbox"/> LoE Line Loss Alarm	Alarm will occur when the zero cross signal does not occur. Caused by loss of line polarity, zero cross or voltage level signal. Also caused by zero cross timing out of tolerance. This alarm will also occur when line voltage is $<$ one-half baseline voltage.
<input type="checkbox"/> ALr <input type="checkbox"/> PbAL Phase Balance Alarm	Alarm will occur when measured voltage of one phase of a 3 phase, 3-leg system is $> 20\%$ different from any other.
<input type="checkbox"/> ALr <input type="checkbox"/> LbAL Load Balance Alarm	Alarm will occur when the load current is determined to be out of balance. User specified in the Setup Page $>$ ALr $>$ LdIF . Default to 100%.
<input type="checkbox"/> ALr <input type="checkbox"/> FrE9 Frequency Out of Tolerance Alarm	Alarm will occur if frequency is not within 47 to 63 Hz.
<input type="checkbox"/> ALr <input type="checkbox"/> UC Line Compensation Alarm	Alarm will occur if the voltage compensation routines cannot compensate for input line voltage changes; occurs for requested power from 5% to 95%, URtb , Ph2E control if UC = ON .
<input type="checkbox"/> ALr <input type="checkbox"/> OU Line Over Voltage Alarm	Alarm will occur if the line voltage is greater than the maximum rated voltage of the device. Caused by line voltage being over line voltage rating $+10\%$.
<input type="checkbox"/> ALr <input type="checkbox"/> Cdo9 Communications Watchdog Alarm	Alarm will occur if no communications is detected for time specified in OUT Watchdog timeout. Not available unless Serial Communications is installed.
<input type="checkbox"/> Err <input type="checkbox"/> HbOC Heater Bakeout Overcurrent Error	Error will occur when the maximum heater current during heater bakeout has been exceeded.
<input type="checkbox"/> Err <input type="checkbox"/> ShrE Shorted SCR Error	The shorted SCR error is detected by measuring current when the SCR is de-energized and comparing this reading to the current measured when the SCR is energized. A shorted SCR error is activated if the de-energized current reading is at least 10A and 25% or more of the energized current reading.
<input type="checkbox"/> Err <input type="checkbox"/> ShrE System Configuration Error	Invalid hardware configuration error.
<input type="checkbox"/> Err <input type="checkbox"/> Ad Analog to Digital Failure Error	Analog to digital failure error.

	Shut-down	Auto Recovery	Modbus Number	Corrective Action
	No		181 r/w (0-4)*	Check wiring connections from load terminal to heater and heater return. Replace heater if necessary.
	No		182 r/w (2) (0-4)*	Check wiring connections from load terminal to heater and heater return. Verify adequate wire size. Replace heater if necessary.
	No		183 r/w (4) (0-4)*	Provide more cabinet ventilation or cooling. Check the fan; if faulty, return to the factory for repair. Check to see that the heat sink is clean. If necessary increase heat sink over temperature value if it is below factory safety shutdown temperature. Return to factory for SCR voltage drop and thermistor evaluation.
	Yes	Yes	184 r/w (8) (0-4)*	Check the line for high noise level and check wiring connections. Possible line sense circuitry error, return to factory for repair. Check FCtY -> d.R9 for L1R1 , L2R1 , or L3R1 , to determine the type and location of the line loss. uUoL can be caused by line voltage < one-half baseline voltage. R.Lr can be caused by noisy line supplies. n.Lr can be caused by a missing line. POL can be caused by a line half cycle or a missing line. FrE9 can be caused by noisy line supplies. HCYC only active with heater diagnostics installed and indicates a half cycle loss detected in the load; can be caused by SCR non-conduction.
	Yes if Ph2E	Yes	185 r/w (0-4)*	Insure that the line voltage is the same for each phase. If line voltages are the same, check line voltages calibrations.
	Yes if Ld.F	Yes	186 r/w (0-4)*	Address load balance on heaters. If loads are balanced, check calibration of current.
	No		187 r/w (0-4)*	Check the power supply line frequency. Power Series will not operate reliably outside 47 to 63 Hz. specification.
	No		188 r/w (0-4)*	Check for major line voltage fluctuations. If line voltage does not fluctuate, check line voltage calibration.
	No		189 r/w (0-4)*	Lower line voltage or damage to the unit may occur. If line voltage is appropriate, check line voltage calibration.
	Yes	No	190 r/w (0-4)*	Insure that the source of communications to the unit is communicating without long interruptions. Verify the integrity of the communications signals from the controlling device. Return to the factory for repair.
	Yes	No	195 r, (1)	It's likely the heater is too wet for heater bakeout time selected. Increase heater bakeout time, cycle power to restart heater bakeout process.
	Yes	No	195 r, (2)	Check output with test instrument while Power (%) 0UE is at 00 . If there is an output, return to the factory for a new SCR. If there is no output, check current calibration.
	Yes	No	195 r, (4)	Cycle control power. If problem persists, return to factory for repair.
	Yes	No	195 r, (8)	Cycle control power. If problem persists, return to factory for repair.

*Inactive - 0, Active - 1, Latched Active - 2, Latched Inactive - 3, Unlatched - 4

Troubleshooting Alarms and Errors (continued)

Alarm / Error	Condition For Alarm or Error To Occur
Checksum Error [Err] [ChE]	Invalid checksum in non-volatile memory error.
Ram Error [Err] [RAM]	Error will occur when RAM failure is detected.
Over Temperature Error [Err] [OE]	Error will occur when heat sink temperature is greater than factory shutdown temperature [SdC].
Half Cycle Line Loss Error [Err] [HCL]	Error will occur if a load half cycle loss is detected during five consecutive zone restart attempts.
Phase Rotation Error [Err] [P_rOE]	Error will occur on a three phase system with a [3L d] load under phase angle control if the phasing is incorrect.

Checking and Replacing Fuses

Ensure that all high voltage power is off. Slide the fuse cover down. Using an ohmmeter, measure the dc resistance of the fuse to determine if it is open. (Typical dc resistance is less than 1 ohm.)

If fuse is open, replace it by removing the old fuse using a 1/2 inch socket and a #3 Phillips screwdriver. Be careful not to drop washers off the bolt or screw ends. If they have dropped into the case, shake them out gently.

The bolt will have 2 washers. The bottom machine screw will have 2 or 3 washers, depending on the size of the SCR in the unit. **It is important that the washers are replaced in the exact order in which they were removed.** Take care installing the fuse so that its orientation matches the image that is printed on the PC board.

With the new fuse (Ferraz, Bussman...) in the unit, torque the bolt to 44 inch-pounds and the screw as follows: For models PXX-F20X-XXXX and PXX-N20X-XXXX torque to 26 in.-lbs. (2.93 Nm.). For models PXX-F25X-XXXX, PXX-N25X-XXXX, PXX-F30X-XXXX, and PXX-N30X-XXXX, torque to 44 in.-lbs. (4.95 Nm.). Close fuse cover. If unit was taken off the wall, observe all terminal torque specs when reconnecting wires. Unit should now be ready to resume operation. Reapply power to the controller and line/load terminals.

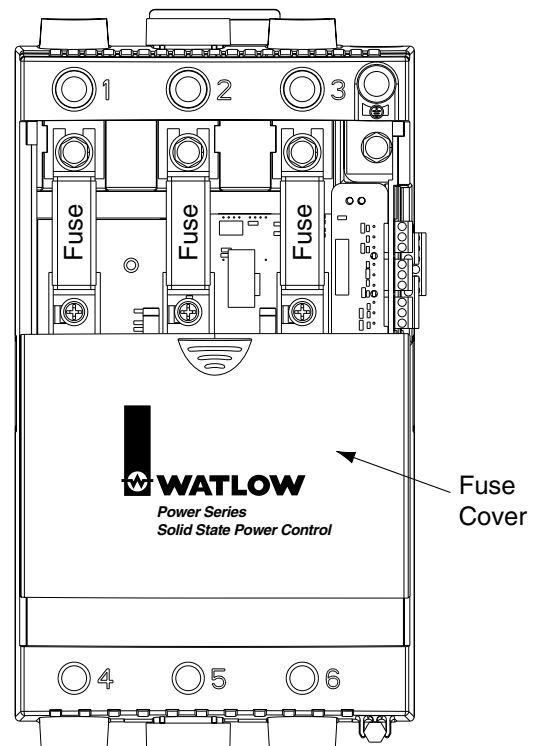

Figure A.6 — Fuse location.

	Shut-down	Auto Recovery	Modbus Number	Corrective Action
	Yes	No	195 r, (16)	Cycle control power. If problem persists, return to factory for repair.
	Yes	No	195 r, (32)	Cycle control power. If problem persists, return to factory for repair.
	Yes	No	195 r, (64)	Provide more cabinet ventilation or cooling. Check the fan; if faulty, return to factory for repair. Check to see that the heat sink is clean. Return to factory for SCR voltage drop and thermistor evaluation.
	Yes	No	195 r, (128)	Line voltage is losing half cycles or SCR is not gating properly. If load is inductive, increase <code>r d L y</code> until error no longer occurs.
	Yes	No	195 r, (256)	Three phase power is connected with incorrect phasing. Swap any two incoming phases.

Power Series Backup

There are three prompts which allow the user to manipulate the EEPROM contents: Backup Data Set, Default Data Set, and Restore Data Set. Each of these prompts have a choice of `ALL`, `545`, `2n 1`, `2n 2`, or `2n 3`.

There are two sets of data stored in the controller; the first is the User EEPROM and it is what is read on every power on. The second is the Backup EEPROM.

The Default Data Set prompt will update the chosen configuration parameters in the User EEPROM to values that are listed in the manual as default. It will update the chosen input and retransmit calibration parameters in the User EEPROM to the values that are stored in the Backup EEPROM by the factory.

The Backup Data Set prompt will update the chosen configuration parameters in the Backup EEPROM from the current values stored in the User EEPROM. It will NOT overwrite the calibration parameters.

The Restore Data Set prompt will update the chosen configuration parameters in the User EEPROM from the current values stored in the Backup EEPROM. It will NOT overwrite the calibration parameters.

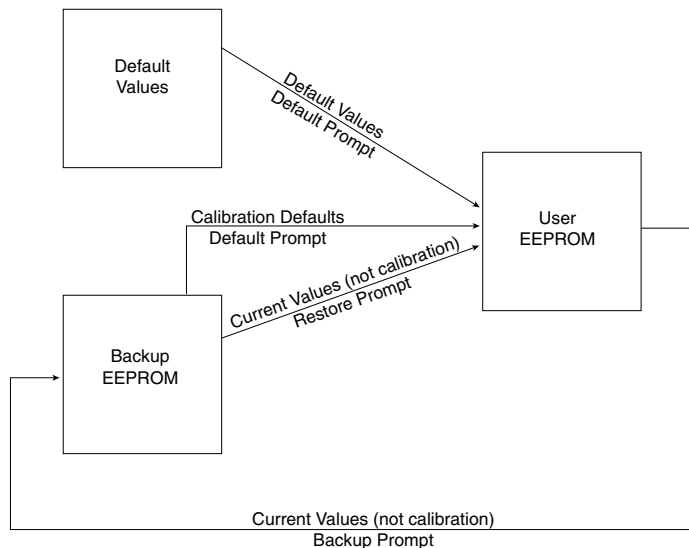

Figure A.7 — Power Series

Modbus Register Numbers

Relative Parameter Numbers (For Absolute Numbers, add 40001 to the Relative Number.)

1	Unit Serial Number High Digits	877	Maximum Amps Retransmit	5105	Soft Start Time (Sec) Zone 1
2	Unit Serial Number Low Digits	878	Minimum kVA Retransmit	5106	Inductive Load Factor Request Zone 1
4	Software Version	879	Maximum kVA Retransmit	5107	Inductive Load Current Zone 1
5	Manufactured Date (yymm)	880	Set Retransmit Output Low Voltage (Volts)	5110	Heater Bakeout Select (On/Off) Zone 1
7	Hardware Version	881	Set Retransmit Output High Voltage (Volts)	5111	Heater Bakeout Select Time Zone 1
30	Software Build Number	882	Set Retransmit Output Low Current (mA)	5112	Current Limit Select (On/Off) Zone 1
50	Unit Current Rating (Amps)	883	Set Retransmit Output High Current (mA)	5113	Current Limit Set Point (A) Zone 1
51	Unit Voltage Rating (Volts)	950	Restore Data Set	5114	Low Tolerance Set Point (A) Zone 1
52	Number Zones Configured	951	Backup Data Set	5115	High Tolerance Set Point (A) Zone 1
53	Hardware Configured Type	952	Default Data Set	5116	Heater Bakeout Overcurrent Trip Zone 1
54	Configuration Installed Options	959	Enable NVOL Storage	5201	Input Signal Method Select (dig, mA, Volt) Zone 2
55	Power Control Algorithm Select	990	Heat Sink Alarm Temp	5202	Numeric (%) Input 2 Signal
56	Fixed Time Base (Sec)	991	Load Balance Percentage	5203	Default Numeric Input Signal (%) Zone 2
57	Factory Safety Shutdown Temp	1350	Global Lockout	5204	Maximum Rate of Change (%/100msec) Zone 2
58	Load Type Select (Control Zone 1 only, 3 Phase only.)	1351	Control Setup Menus Lockout	5205	Soft Start Time (Sec) Zone 2
80	Voltage Compensation (On/Off)	1352	Options Setup Menus Lockout	5206	Inductive Load Factor Request Zone 2
85	Comms Watchdog Select (On/Off)	1353	Alarms Setup Menu Lockout	5207	Inductive Load Current Zone 2
86	Comms Watchdog Timeout (S)	1354	Comms Setup Menu Lockout	5210	Heater Bakeout Select (On/Off) Zone 2
87	Comms Watchdog Failure Output Power Select	1355	Retransmit Setup Menu Lockout	5211	Heater Bakeout Select Time Zone 2
150	Analog (mA) Input 1 Signal	1356	Analog Input Factory Menus Lockout	5212	Current Limit Select (On/Off) Zone 2
151	Analog (V) Input 1 Signal	1357	Retransmit Cal Factory Menu Lockout	5213	Current Limit Set Point (A) Zone 2
152	Line Potential (Volts) rms Line 1	1358	System Data Factory Menu Lockout	5214	Low Tolerance Set Point (A) Zone 2
153	A/D Counts Input 1	1359	Diagnostics Factory Menu Lockout	5215	High Tolerance Set Point (A) Zone 2
154	Load Current (Amps) rms Line 1	1513	Display Test	5216	Heater Bakeout Overcurrent Trip Zone 2
156	Load Power (kVA) Zone 1	1540	Line Loss Alarm, Most Recent Type, Line 1	5301	Input Signal Method Select (dig, mA, Volt) Zone 3
157	Heater Bakeout Timeout Zone 1	1541	Line Loss Alarm, Previous Type, Line 1	5302	Numeric (%) Input 3 Signal
159	Output 1 Power (%)	1542	Line Loss Alarm, Least Recent Type, Line 1	5303	Default Numeric Input Signal (%) Zone 3
160	Analog (mA) Input 2 Signal	1543	Line Loss Alarm, Most Recent Type, Line 2	5304	Maximum Rate of Change (%/100msec) Zone 3
161	Analog (V) Input 2 Signal	1544	Line Loss Alarm, Previous Type, Line 2	5305	Soft Start Time (Sec) Zone 3
162	Line Potential (Volts) rms Line 2	1545	Line Loss Alarm, Least Recent Type, Line 2	5306	Inductive Load Factor Request Zone 3
163	A/D Counts Input 2	1546	Line Loss Alarm, Most Recent Type, Line 3	5307	Inductive Load Current Zone 3
164	Load Current (Amps) rms Line 2	1547	Line Loss Alarm, Previous Type, Line 3	5310	Heater Bakeout Select (On/Off) Zone 3
166	Load Power (kVA) Zone 2	1548	Line Loss Alarm, Least Recent Type, Line 3	5311	Heater Bakeout Select Time Zone 3
167	Heater Bakeout Timeout Zone 2	1555	Retransmit Set Test Word	5312	Current Limit Select (On/Off) Zone 3
169	Output 2 Power (%)	1560 to 1573	Read Selected A/D Counts	5313	Current Limit Set Point (A) Zone 3
170	Analog (mA) Input 3 Signal	1580	Select Discrete Input	5314	Low Tolerance Set Point (A) Zone 3
171	Analog (V) Input 3 Signal	1581	Read Selected Input Value	5315	High Tolerance Set Point (A) Zone 3
172	Line Potential (Volts) rms Line 3	1590	Heat Sink Temp (°C)	5316	Heater Bakeout Overcurrent Trip Zone 3
173	A/D Counts Input 3	1591	Record High Heat Sink Temp	5411	Adjust Low mA Cal Point Zone 1
174	Load Current (Amps) rms Line 3	1700	Factory Mode Request	5412	Adjust High mA Cal Point Zone 1
176	Load Power (kVA) Zone 3	1799	Factory Password Entry	5413	Adjust Low V Cal Point Zone 1
177	Heater Bakeout Timeout Zone 3	1960	Accum Hours (10K - 100M)	5414	Adjust High V Cal Point Zone 1
179	Output 3 Power (%)	1961	Accum Hours (0 - 9999)	5415	Calibrate Analog Input Request Zone 1
180	Active Alarms	5011	Set Analog Input Low Current Scale (mA) Zone 1	5421	Adjust Low mA Cal Point Zone 2
181	Heater Open alarm	5012	Set Analog Input High Current Scale (mA) Zone 1	5422	Adjust High mA Cal Point Zone 2
182	Heater Tolerance Alarm	5013	Set Analog Input Low Voltage Scale (Volts) Zone 1	5423	Adjust Low V Cal Point Zone 2
183	Heat Sink Over Temperature Alarm	5014	Set Analog Input High Voltage Scale (Volts) Zone 1	5424	Adjust High V Cal Point Zone 2
184	Line Loss Alarm	5019	Learn Input Request (Hi, Lo) Zone 1	5425	Calibrate Analog Input Request Zone 2
185	Phase Balance Alarm	5021	Set Analog Input Low Current Scale (mA) Zone 2	5431	Adjust Low mA Cal Point Zone 3
186	Load Balance Alarm	5022	Set Analog Input High Current Scale (mA) Zone 2	5432	Adjust High mA Cal Point Zone 3
187	Frequency Out of Tolerance Alarm	5023	Set Analog Input Low Voltage Scale (Volts) Zone 2	5433	Adjust Low V Cal Point Zone 3
188	Line Compensation Alarm	5024	Set Analog Input High Voltage Scale (Volts) Zone 2	5434	Adjust High V Cal Point Zone 3
189	Line Over Voltage Alarm	5029	Learn Input Request (Hi, Lo) Zone 2	5435	Calibrate Analog Input Request Zone 3
190	Communications Watchdog Alarm	5031	Set Analog Input Low Current Scale (mA) Zone 3	5591	Baseline Voltage Learn Request Zone 1
195	Active Errors	5032	Set Analog Input High Current Scale (mA) Zone 3	5592	Baseline Voltage Learn Request Zone 2
198	Line Frequency (Hz)	5033	Set Analog Input Low Voltage Scale (Volts) Zone 3	5593	Baseline Voltage Learn Request Zone 3
850	Active Relay State	5034	Set Analog Input High Voltage Scale (Volts) Zone 3	5594	Baseline Voltage Read/Adjust Zone 1
851	Global Alarm Configuration	5039	Learn Input Request (Hi, Lo) Zone 3	5595	Baseline Voltage Read/Adjust Zone 2
860	Heater Open Alarm Config.	5101	Input Signal Method Select (dig, mA, Volt) Zone 1	5596	Baseline Voltage Read/Adjust Zone 3
861	Heater Tolerance Alarm Config.	5102	Numeric (%) Input 1 Signal	5700	Cal Retransmit Request
862	Over Temperature Alarm Config.	5103	Default Numeric Input Signal (%) Zone 1	5710	Retransmit Cal mA Low
863	Line Loss Alarm Configuration	5104	Maximum Rate of Change (%/100msec) Zone 1	5711	Retransmit Cal mA High
864	Phase Balance Alarm Config.			5720	Retransmit Cal Volts Low
865	Load Balance Alarm Config.			5721	Retransmit Cal Volts High
866	Frequency Out of Tolerance Alarm Configuration				
867	Voltage Compensation Alarm Config.				
868	Over Voltage Alarm Config.				
869	Comms Watchdog Alarm Configuration				
870	Retransmit Config. Select				
871	Retransmit Type Select				
872	Retransmit Phase Select				
873	Retransmit Zone Select				
876	Minimum Amps Retransmit				

Specifications (2214)

Power Bases

- Single phase, (2 SCRs)
- 3 phase, 2-leg control, (4 SCRs)
Resistive load only, zero cross firing only
- 3 phase, 3-leg control, (6 SCRs)
- 3 phase, 3-leg control, (6 SCRs) for 4 wire wye loads
- Multizone, two and three single phase zones

Output Control Options

- Zero cross contactor, $V_{\text{=}}(\text{dc})$ input
- Zero cross control, fixed time base
 - Time base 1 or 4 seconds with digital programmer
- Zero cross control, variable time base
- Phase angle control and phase angle control with current limit (not for 3 phase, 2-leg models)
 - Soft start factory default 4 seconds upon power-up, and adjustable from 0.0 to 120 seconds
 - Soft start upon input signal change, output rate of change adjustable to limit max rate of change from 0.1 to 100% per 0.1 second. Factory default 10%.
- Current transformer included when required
- Line voltage compensated (variable time base and phase angle controllers only)
- Standby or non-operational mode

Output Voltage and Current Rating

- 24V~(ac) to 120V~(ac)(+10%, -15%)
- 200V~(ac) to 480V~(ac)(+10%, -15%)
- 200V~(ac) to 600V~(ac)(+10%, -15%)
- 65 through 250 amps per pole, model dependent; see Output Amperage Chart and Rating Curves
- Minimum load 1 amp rms ac
- Typical leakage current 5mA

Alarms

- Single alarm relay
- Latching or non-latching
- Alarm silencing (inhibit) on power up for alarm
- Alarm indication LEDs, shorted SCR, open heater, fuse
- Electromechanical relay, form C contact, software configurable
 - Minimum load current 10mA @ 5V~(dc)
 - Rated resistive loads: 3 amps @ 250V~(ac) or 30V~(dc) max., inductive load rating 1.5 amps with a power factor \geq 0.4 without contact suppression

Heater Bakeout

- For single phase (phase to neutral) and 3 phase 6 SCR models only (not for 3 phase, 2-leg models)
- Soft start with over current trip, runs until programmed bakeout time expires, then goes zero cross or phase angle firing. Factory default of 24 hours.
- Adjustable 0 - 9999 minutes with over current trip
- Internal current transformer included

Command Signal Input

Analog

- DC contactor 3.5 to 10V~(dc), must turn off at 2.5V~(dc)
- Field selectable linear voltage and current of low and high points within 0-20mA and 0-10V~(dc)
- Manual control input through front panel
- Factory default 0-20mA input
- Voltage input impedance 11k Ω nominal
- Current input impedance 100 Ω nominal

Digital

- On-board digital programmer/display and optional serial communications

Retransmit

- Field selectable and scalable within 0-20mA, 800 Ω maximum load or 0-10V~(dc), 1K Ω minimum load. The default is 4-20mA.
- Resolution:
 - mA ranges = 5 μ A nominal
 - V~(dc) = ranges 2.5mV nominal

- Calibration accuracy:
 - mA ranges = $\pm 20\mu$ A
 - V~(dc) ranges = ± 10 mV
- Temperature Stability: 100ppm $^{\circ}$ C

Digital Programmer/Display and Communications Capabilities

- Programming functions
 - Adjust input and output control type, alarms and soft start. Heater bakeout and current limit prompts also.
- Monitoring functions
 - Display input and output values along with actual output current
- Data retention of digital programmer/display upon power failure via nonvolatile memory

Serial Communications

- RS-232 for single drop control
- EIA-485 for single or multidrop control
 - 32 units maximum can be connected. With additional 485 repeater hardware, up to 247 units may be connected
- Isolated
- Modbus™ RTU protocol
- 1200, 2400, 4800, 9600, 19200 baud rates

Controller Power Supply

- Universal line voltage input range 100 to 240V~(ac) (+10%, -15%) @ 55VA maximum
- 50/60Hz \pm 5% line frequency independent
- Controller line voltage for electronic power supply can be run on separate line voltage

Natural Convection and Fan Cooled Models

- Cabinet venting may be required

Power Dissipation (Watts)

- Approximately 1.25 watts/amp per controlled leg

Isolation

- Command signal to load and line/load to ground 2200V~(ac) minimum
- On-board semiconductor fuses provide SCR protection

Mounting

- Mounts on a removable sub-plate
- Heat sink fins must be mounted in vertical orientation

High Current Terminals

- Touch safe
- 3/8 inch Allen head compression terminals will accept #6 AWG to 350 MCM wire. Allen wrench adapter (included) for 3/8 inch socket, or 10 mm, 6 point only.
- Torque to 180 in.-lbs. (20.3 Nm.)
- Wire strip to 30 mm (1-1/8 inch)

Controller Terminals

- Touch safe
- 2.5 mm (1/8 inch) blade screwdriver, accepts 12-22 AWG or 2 No. 22-18 AWG wires.
- Torque to 8 in.-lbs. (0.9 Nm.)
- Wire strip to 6 mm (0.24 inch)

Operating Environment

- 50 $^{\circ}$ C (122 $^{\circ}$ F) base rating
 - 0 to 60 $^{\circ}$ C (32 to 140 $^{\circ}$ F) fan cooled
 - 0 to 65 $^{\circ}$ C (32 to 149 $^{\circ}$ F) natural convection cooled
- 0 to 90% RH, non-condensing
- Meets EN50178, Pollution degree 3

Storage Temperature

- -40 to 85 $^{\circ}$ C (-40 to 185 $^{\circ}$ F)

Dimensions

- Width x height x depth
191 mm x 354 mm x 200 mm
(7.5 in x 14.0 in x 7.9 in)

Shipping Weight

- 10.3 kg. (23 lbs.)

Agency Approvals

- UL 508 and C-UL listed, file #E73741
- CE marked, see Declaration of Conformity on page A.14
- VDE 0160 License #115054

Ordering Information

(1528)

To order, complete the code number to the right with the information below:

Power Series = Microprocessor-Based Solid State Power Controller

Package Style _____

C = 65 to 250 Amps

Phase _____

- 1 = 1 phase
- 2 = 3 phase-2-leg control (4 SCRs)
- 3 = 3 phase-3-leg control (6 SCRs)
- 4 = 3 phase-4-wire, wye connected load
- 8 = 2 single phase zones
- 9 = 3 single phase zones

Heater Diagnostics (includes current limit) _____

- 0 = None
- 1 = Heater Diagnostics (Current Limiting and Heater Bakeout are only available on single phase and 3 phase, 3-leg Controllers)

Output Amperage Rating _____

(See Amperage Chart below; insert code number here.)

Output Voltage Rating _____

- A = 24 to 120V~
- B = 200 to 480V~
- C = 200 to 600V~

Communications _____

- 0 = None
- 1 = EIA/TIA 232/485 communications, isolated (field selectable)

Feedback/Retransmit _____

- 0 = None
- 1 = Load current feedback (0-10V or 0-20mA scalable retransmit output) (Must have heater diagnostics selected.)

Custom _____

- 00 = None
- AA = No Watlow logo with agency approval marks
- AB - ZZ = Custom, consult factory for options

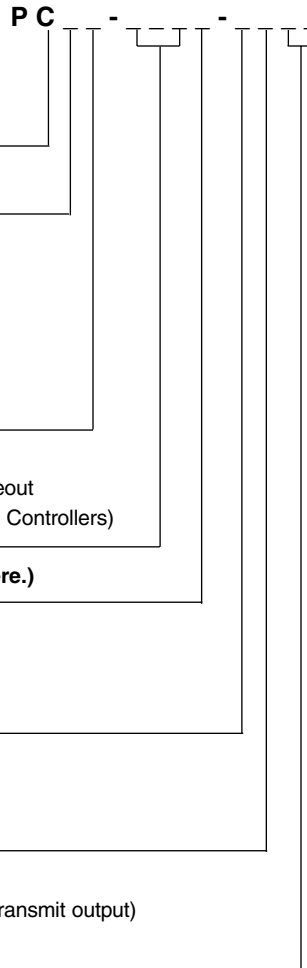

IMPORTANT NOTES:

Phase Angle: Phase angle and phase angle with current limit are available on single phase, and 3 phase/3-leg models only. To get current limiting, you must also order heater diagnostics.

Heater Bakeout: Heater bakeout is available on single phase, and 3 phase/3-leg models with heater diagnostics.

Amperage Chart @ 50°C (122°F)

	<u>Single Phase</u>		<u>2 Single Phase Zones</u>		<u>3 Single Phase Zones</u>	
	<u>Code</u>	<u>Amperage</u>	<u>Code</u>	<u>Amperage</u>	<u>Code</u>	<u>Amperage</u>
Non Fan Cooled	N20	100A	N20	80A	N20	65A
	N25	140A	N25	105A	N25	85A
	N30	165A	N30	120A	N30	105A
Fan Cooled	F20	125A	F20	120A	F20	90A
	F25	200A	F25	160A	F25	140A
	F30	250A	F30	185A	F30	155A

NOTE: User documentation may be available in French, German, Spanish, Italian, and Dutch, as well as English. Check Watlow's website (www.watlow.com/) for availability.

Index

A

- A to D Failure Error A.4
- Accum Hours (0 - 9999) 6.18
- Accum Hours (10K - 100M) 6.18
- Active Alarms 6.1
- Active Relay State 6.10
- Adjust High mA Cal Point Zones 1-3 6.21
- Adjust High V Cal Point Zones 1-3 6.21
- Adjust Low mA Cal Point Zones 1-3 6.21
- Adjust Low V Cal Point Zones 1-3 6.21
- Alarms 5.7
 - active relay state 5.7
 - global 5.7
 - latched 5.7
 - latched and silenced 5.7
 - silencing 5.7
 - standard 5.7
- Alarms Setup Menu Lockout 6.16
- Alarms, troubleshooting A.4-A.5
 - communications watchdog alarm A.4
 - frequency out of tolerance alarm A.4
 - heat sink over temperature alarm A.4
 - heater open alarm A.4
 - heater tolerance alarm A.4
 - line compensation alarm A.4
 - line loss alarm A.4
 - line over voltage alarm A.4
 - load balance alarm A.4
 - phase balance alarm A.4

- Ambient Temperature Rating 2.1
- Analog (mA) Input 1 Signal 6.2, 6.3
- Analog (mA) Input 2 Signal 6.2, 6.3
- Analog (mA) Input 3 Signal 6.3
- Analog (mA) Input Signal 6.1
- Analog (V) Input 1 Signal 6.2, 6.3
- Analog (V) Input 2 Signal 6.2, 6.3
- Analog (V) Input 3 Signal 6.3
- Analog (V) Input Signal 6.1, 6.4
- Analog Input Factory Menus Lockout 6.16

B

- Backup A.7
- Backup Data Set 6.15
- Baseline Voltage 5.6
- Baseline Voltage Learn Req. Zones 1-3 6.7
- Baseline Voltage Read/Adj. Zones 1-3 6.7

C

- Cal Retransmit Request 6.22
- Calibrate Analog Input Req. Zones 1-3 6.21
- Calibrate Analog Input Signal Zones 1-3 Menus 6.21
- Calibrate Retransmit Menu 6.22
- Comms Setup Menu Lockout 6.16
- Comms Watchdog Alarm Config. 6.11
- Communications 5.8
- Communications Watchdog Alarm A.4
- Configuration Installed Options 6.18

- Control Configurations 1.2
 - 3 phase, 2-leg 1.2
 - 3 phase, 3-leg 1.2
 - 3 phase, multizone 1.2
 - single phase 1.2
- Control Setup Menus Lockout 6.16
- Cooling 2.3
- Current Limit Select (On/Off) Zones 1-3 6.8
- Current Limit Set Point (A) Zones 1-3 6.9
- Current Limiting 5.5

D

- DC Contactor - Zero Cross 5.2
- Default Data Set 6.15
- Default Numeric Input Sig. (%) Zones 1-3 6.6
- Diagnostics Factory Menu Lockout 6.17
- Diagnostics Menu 6.19-6.20
- Dimensions 2.2
- Display Loop Errors 6.1, A.4-A.7
- Display Loop Menu 4.2, 4.3
- Display Phase Selection 1-3 6.4
- Display Test 6.20
- Display Zone Selection 6.2, 6.3

E

- Enable NVOL Storage 6.16
- Enclosure Guidelines 2.3
- Errors, troubleshooting A.4-A.5
 - A to D failure error A.4
 - half cycle line loss error A.6
 - heater bakeout overcurrent error A.4
 - nonvolatile memory checksum error A.6
 - over temperature error A.6
 - phase rotation error A.6
 - RAM error A.6
 - shorted SCR error A.4
 - system configuration error A.4

F

- Factory Mode 6.20
- Factory Mode Request 6.20
- Factory Page Menu 4.2, 4.4
- Factory Page Parameters 6.14 - 6.22
- Factory Password 6.20
- Factory Password Entry 6.20
- Factory Safety Shutdown Temp 6.18
- Fan Cooled Output Rating Curves 2.5
- Fast Start Guide 5.10
- Fixed Time Base (Sec) 6.5
- Fixed Time Base - Zero Cross 5.1
- Frequency Out of Tol. Alarm Config. 6.11
- Frequency Out of Tolerance Alarm A.4
- Fuse Replacement A.6

G

- Global Alarm Configuration 5.7, 6.10
- Global Lockout 5.6, 6.16
- Global/Menu Lockouts Menu 6.16-6.17

H

- Half Cycle Line Loss Error A.6
- Hardware Version 6.17
- Harsh Environment 2.3
- Heat Sink Alarm Temp 6.18
- Heat Sink Over Temperature Alarm A.4
- Heat Sink Over Temperature Alarm

- Configuration 6.10
- Heat Sink Over Temperature Alarm Temperature 6.10
- Heat Sink Temp (°C) 6.18
- Heater Bakeout 5.4
- Heater Bakeout Overcurrent Error A.4
- Heater Bakeout Overcurrent Trip Zones 1-3 6.8
- Heater Bakeout Select (On/Off) Zones 1-3 6.8
- Heater Bakeout Select Time Zones 1-3 6.8
- Heater Bakeout Timeout 6.2
- Heater Bakeout Timeout Zone 1 6.2, 6.3
- Heater Bakeout Timeout Zone 2 6.2, 6.3
- Heater Bakeout Timeout Zone 3 6.3
- Heater Diagnostics Feature 1.2
- Heater Open Alarm A.4
- Heater Open Alarm Config. 6.10
- Heater Tolerance Alarm A.4
- Heater Tolerance Alarm Config. 6.10
- Heater Tolerance Detection 5.4
- High Tolerance Set Point (A) Zones 1-3 6.9

I J

- Inductive Current 6.9
- Inductive Load Factor Request 6.9
- Input 5.6
 - signal selection 5.6
- Input Signal Method Select (dig, mA, Volt) Zones 1-3 6.6
- Input Wiring 3.2-3.3
 - 2 zone 3.3
 - 3 zone 3.3
 - communications 3.2
 - control power and alarm 3.2
 - retransmit 3.2
 - single zone 3.3
- Installation 2.1-2.6

K

- Keys and Displays 4.1

L

- Learn Input Learn Req. (Hi, Lo) Zones 1-3 6.7
- Line Compensation Alarm A.4
- Line Frequency (Hz) 6.1
- Line Loss Alarms 6.19, A.4
- Line Loss Alarm Configuration 6.10
- Line Over Voltage Alarm A.4
- Line Potential (Volts) rms Zone 1 6.3, 6.4
- Line Potential (Volts) rms Zone 2 6.3, 6.4
- Line Potential (Volts) rms Zone 3 6.3, 6.4
- Line Potential (Volts) rms 6.2
- Line Power Wiring 3.4
- Line Voltage Compensation 6.6
- Load Activity Indicator 6.1
- Load Balance Alarm A.4
- Load Balance Alarm Config. 6.11
- Load Balance Percentage 6.11
- Load Current (Amps) rms 6.2
- Load Current (Amps) rms Zone 1 6.3, 6.4
- Load Current (Amps) rms Zone 2 6.3, 6.4
- Load Current (Amps) rms Zone 3 6.4
- Load Power (kVA) 6.2, 6.4
- Load Power (kVA) Zone 1 6.3, 6.4

Load Power (kVA) Zone 2 6.3, 6.4
Load Power (kVA) Zone 3 6.4
Load Type Select (Control Zone 1 only, 3 phase only.) 6.7
Low Tolerance Set Point (A) Zone 1-3 6.9

M

Maintenance 2.4
Manufactured Date (yy/mm) 6.17
Maximum Amps Retransmit 6.13
Maximum kVA Retransmit 6.13
Maximum Rate of Change 5.3
adjustable on signal change 5.3
Maximum Rate of Change
(%/100msec) Zone 1-3 6.8
Menu Lock 5.6
Minimum Amps Retransmit 6.13
Minimum kVA Retransmit 6.13
Model Number A.10
Mounting 2.2-2.3

N

Natural Convection Output Rating
Curves 2.6
Navigation and Software 4.1-4.4
Nonvolatile Memory Checksum Error
A.4
Number Zones Configured 6.18
Numeric (%) Input 1 Signal 6.2, 6.3, 6.4
Numeric (%) Input 2 Signal 6.2, 6.3, 6.4
Numeric (%) Input 3 Signal 6.3, 6.4
Numeric (%) Input Signal 6.1

O

Options Setup Menus Lockout 6.16
Output 1 Power (%) 6.2, 6.3, 6.4
Output 2 Power (%) 6.2, 6.3
Output 3 Power (%) 6.2, 6.3
Output Power (%) 6.2, 6.4
Output Rating Curves 2.5-2.6
Output Wiring 3.4-3.5
3 phase, 2-leg, 4 SCR 3.4
3 phase, 3-leg, 6 SCR, 4-wire wye 3.5
3 phase, 3-leg, SCR/diode hybrid 3.5
multizone 3.5
single phase 3.4
Over Temperature Error A.6
Over Voltage Alarm Config. 6.11

P Q

Phase Angle 5.2
Phase Balance Alarm A.4
Phase Balance Alarm Config. 6.11
Phase Rotation Error A.6
Power Control Algorithm Select 6.5
Prompt Index A.13

R

RAM Error A.6
Read Selected Analog to Digital
Counts 6.19
Read Selected Input Value 6.20
Record High Heat Sink Temp 6.18
Removing the Power Series 2.4
Restore Data Set 6.15
Retransmit 5.9
Retransmit Cal Factory Menu
Lockout 6.16
Retransmit Cal mA High 6.22
Retransmit Cal mA Low 6.22

Retransmit Cal Volts High 6.22
Retransmit Cal Volts Low 6.22
Retransmit Config. Select 6.12
Retransmit Phase Select 6.13
Retransmit Set Test Word 6.20
Retransmit Setup Menu Lockout 6.16
Retransmit Type Select 6.12
Retransmit Wiring 3.2
Retransmit Zone Select 6.13

S

Safety Information inside front cover
Select Analog to Digital Channel 6.19
Select Discrete Input 6.20
Set Analog Input High Cur. (mA)
Zone 1-3 6.6
Set Analog Input High Volt. (Volts)
Zone 1-3 6.7
Set Analog Input Low Cur. (mA)
Zone 1-3 6.6
Set Analog Input Low Volt. (Volts)
Zone 1-3 6.6
Set Retransmit Output High Cur. (mA)
6.13
Set Retransmit Output High Volt. (Volts)
6.14
Set Retransmit Output Low Cur. (mA) 6.13
Set Retransmit Output Low Volt. (Volts) 6.14
Setup Alarms Configuration Menu 6.10-
6.11
Setup Comms Configuration Menu 6.12
Setup Control Algorithm 6.5
Setup Control Zone 1, 2, and 3 Menus
6.6-6.7
Setup Options Zone 1, 2, and 3 Menus
6.8-6.9
Setup Page Menu 4.2, 4.4
Setup Page Parameters 6.5 - 6.13
Setup Page Select 6.5
Setup Retransmit Configuration Menu
6.12-6.14
Shorted SCR Error A.4
Signal Selection 5.6
Soft Start 5.3
adjustable on power up 5.3
Soft Start Time (Sec) Zones 1-3 6.8
Software Build Number 6.17
Software Version 6.17
Specification A.9
System Configuration Error A.4
System Data Factory Menu Lockout 6.17
System Data Manipulation Menu 6.15

T

Technical Assistance inside front cover
Torque 3.1, 3.2, 3.4
Troubleshooting A.2-A.3
Troubleshooting Alarms and Errors
A.4-A.7

U V

Unit Address Select 6.12
Unit Baud Rate Select 6.12
Unit Current Rating (Amps) 6.18
Unit Information Menu 6.17-18
Unit Serial Number High Digits 6.17
Unit Serial Number Low Digits 6.17
Unit Voltage Rating (Volts) 6.17
Variable Time Base - Zero Cross 5.2
Voltage Compensation Alarm Config. 6.11

W X Y Z

Warnings and Cautions inside front
cover
Warranty Information back cover
Watchdog Failure Output Power Select
6.12
Watchdog Select (On/Off) 6.12
Watchdog Timeout 6.12
Wire Bending Radius 2.1
Wire Stripping 3.1, 3.2, 3.4
Wiring 3.1-3.6
input 3.2-3.3
output 3.4-3.5
Wiring Example 3.6
Your Comments inside front cover
Zero Cross 5.1

Prompt Index

- A**
- Ad** Select Analog to Digital Channel 6.19
 - Addr** Unit Address Select 6.12
 - ALC** Heat Sink Alarm Temp 6.18
 - ALC** Heat Sink Over Temperature Alarm Temperature 6.10
 - AL9c** Active Relay State 6.10
 - AL9o** Power Control Algorithm Select 6.5
 - AL9o** Setup Control Algorithm Menu 6.5-6.6
 - ALr** Alarms Setup Menu Lockout 6.16
 - ALr** Setup Alarms Configuration Menu 5.7, 6.10-6.11
- B**
- bAud** Unit Baud Rate Select 6.12
 - bUpP** Backup Data Set 6.15
 - bU** Baseline Voltage Read/Adjust 6.7
- C**
- C** Heat Sink Temperature (°C) 6.18
 - CLAR** Calibrate Analog Input Request 6.21
 - CLr** Cal Retransmit Request 6.22
 - CF9** Retransmit Configuration Select 6.12
 - CIn** Analog Input Factory Menus Lockout 6.16
 - CIn1** **CIn2** **CIn3** Calibrate Analog Input Signal Zone 1, 2, or 3 Menus 6.21-6.22
 - CLA** Current Limit Set Point (A) 5.5, 6.9
 - CLi** Current Limit Select (On/Off) 5.5, 6.8
 - COF9** Comms Setup Menu Lockout 6.16
 - COF9** Setup Comms Configuration Menu 6.12
 - CnES** Read Selected Analog to Digital Counts 6.19
 - cont** dc contactor 5.2
 - Crtr** Retransmit Cal Factory Menu Lockout 6.16
 - Crtr** Calibrate Retransmit Menu 6.22
 - Cr** Control Setup Menus Lockout 6.16
 - Cr1** **Cr2** **Cr3** Setup Control Zone 1, 2, and 3 Menus 6.6-6.8
 - Cur** Load Current (Amps) rms 6.2
 - Cur1** **Cur2** **Cur3** Load Current (Amps) rms 6.3, 6.4
 - Cur** Maximum Amps Retransmit 6.13
 - Cur** Minimum Amps Retransmit 6.13
 - Cvdd** Comms Watchdog Alarm Configuration 6.11
- D**
- dAER** System Data Factory Menu Lockout 6.17
 - dAER** System Data Manipulation Menu 6.15-6.16
 - dAEE** Manufactured Date (yymm) 6.17
 - dFLt** Default Data Set 6.15
 - dFLt** Default Numeric Input Signal (%) 6.6
 - d.r99** Diagnostics Factory Menu Lockout 6.17
 - d.r99** Diagnostics Menu 6.19-6.20
 - dISP** Display Test 6.20
- E F**
- FcEY** Factory Mode Request 6.20
 - FcEY** Factory Page 6.14 - 6.22
 - FrE9** Frequency Out of Tolerance Alarm Configuration 6.11
 - FrE9** Line Frequency (Hz) 6.1
 - Ftb** Fixed Time Base 5.1
 - Ftb** Fixed Time Base (Sec) 6.5
- G**
- GLbL** Global Alarm Configuration 5.7, 6.10
 - GLoC** Global Lockout 5.6, 6.16
- H**
- HbC** Heater Bakeout Overcurrent Trip 6.8
 - Hbo** Heater Bakeout Select (On/Off) 5.4, 6.8
 - Hbt** Heater Bakeout Timeout 6.2
 - Hbt1** **Hbt2** **Hbt3** Heater Bakeout Timeout 6.2, 6.3
 - HiC** Record High Heat Sink Temp 6.18
 - HrS** Accum Hours (10K - 100M) 6.18
 - HrS** Accum Hours (0 - 9999) 6.18
 - HUR** Load Power (kVA) 6.2, 6.4
 - HUR** Maximum kVA Retransmit 6.13
 - HUR** Minimum kVA Retransmit 6.13
 - HUR1** **HUR2** **HUR3** Load Power (kVA) 6.3, 6.4
 - HUEr** Hardware Version 6.17
- I J K**
- ICur** Inductive Current 6.9
 - In** Analog (mA or V) or Numeric (%) Input Signal 6.1, 6.4
 - In** Input Signal Method Select (dig, mA, volt) 6.6
 - In** Select Discrete Input 6.20
 - In1** **In2** **In3** Analog (mA or V) or Numeric (%) Input Signal 6.2, 6.3
 - IndF** Inductive Load Factor Request 6.9
 - InfO** Unit Information Menu 6.17-6.18
- L**
- LlR1** Line Loss Alarm, Most Recent 6.19
 - LlR2** **LlR3** **LlR2** **LlR3** Line Loss 6.19
 - LlR3** **LlR3** **LlR3** Alarm Type 6.19
 - LlR1** Line Loss Alarm, Previous 6.19
 - LlR1** Line Loss Alarm, Least Recent 6.19
 - LbAL** Load Balance Alarm Config. 6.11
 - Ld.F** Load Balance Percentage 6.11
 - LnE** Line Loss Alarm Config. 6.10
 - LoAd** Load Activity Indicator 6.1
 - LoC** Global/Menu Lockouts Menu 6.16-6.17
 - Lrn.R** Learn Input Learn Request (Hi, Lo) 6.7
 - Lrn.U** Baseline Voltage Learn Request 6.7
- M N**
- MIn** Heater Bakeout Select Time 5.4, 6.8
 - nnA** Adjust High mA Cal Point 6.21
 - nnA** Adjust Low mA Cal Point 6.21
 - nnA** Retransmit Cal mA High 6.22
 - nnA** Retransmit Cal mA Low 6.22
 - nnA** Set Analog Input High Current (mA) 6.6
 - nnA** Set Analog Input Low Current (mA) 6.6
 - nUOL** Enable NVOL Storage 6.16
- O**
- OPEn** Heater Open Alarm Config. 6.10
 - OPt** Config. Installed Options 6.18
 - OPt** Options Setup Menus Lockout 6.16
 - OPt1** **OPt2** **OPt3** Setup Options Zone 1, 2, and 3 Menus 6.8-6.9
 - OT** Heat Sink Over Temperature Alarm Configuration 6.10
 - OU** Over Voltage Alarm Config. 6.11
 - OvE** Output Power (%) 6.2, 6.4
 - OvE1** **OvE2** **OvE3** Output Power (%) 6.2, 6.3
- P Q**
- P.bAL** Phase Balance Alarm Config. 6.11
 - PhAS** Display Phase 6.4
 - PhAS** Retransmit Phase Select 6.13
 - PhZE** Phase Angle 5.2
 - PLJ** Factory Password 6.20
 - PLJ** Factory Password Entry 6.20
 - PLJr** Watchdog Failure Output Power Select (%) 6.12
- R**
- rAER** Unit Current Rating (Amps) 6.18
 - rAEE** Maximum Rate of Change (%/100msec) 6.8
 - rAEU** Unit Voltage Rating (Volts) 6.17
 - rDLy** Reactance Delay 6.8
 - rESE** Restore Data Set 6.15
 - rEtr** Retransmit Set Test Word 6.20
 - rEtr** Retransmit Setup Menu Lockout 6.16
 - rEtr** Setup Retransmit Configuration Menu 6.12-6.14
 - re.C** Set Retransmit Output High Current (mA) 6.13
 - re.C** Set Retransmit Output Low Current (mA) 6.13
 - re.U** Set Retransmit Output High Voltage (Volts) 6.14
 - re.U** Set Retransmit Output Low Voltage (Volts) 6.14
- S**
- SbLd** Software Build Number 6.17
 - SdC** Factory Safety Shutdown Temp 6.18
 - SEC** Watchdog Timeout (Sec) 6.12
 - SEE** Setup Page Select 6.5-6.13
 - Sn** Unit Serial Number High Digits 6.17
 - Sn** Unit Serial Number Low Digits 6.17
 - SoFE** Soft Start 5.3
 - SoFE** Soft Start Time (Sec) 6.8
 - SUER** Software Version 6.17
- T**
- tOL** Heater Tolerance Alarm Configuration 6.10
 - tOL** High Tolerance Set Point (A) 6.9
 - tOL** Low Tolerance Set Point (A) 6.9
 - TYPE** Load Type Select 6.7
 - TYPE** Retransmit Type Select 6.12
- U V W X Y Z**
- UAl** Read Selected Input Value 6.20
 - Uc** Line Voltage Compensation 6.6
 - Uc** Voltage Compensation Alarm Configuration 6.11
 - UoL** Line Potential (Volts) rms 6.2
 - UoL1** **UoL2** **UoL3** Line Potential (Volts) rms 6.3, 6.4
 - UoL** Adjust High V Cal Point 6.21
 - UoL** Adjust Low V Cal Point 6.21
 - UoL** Retransmit Cal Volts High 6.22
 - UoL** Retransmit Cal Volts Low 6.22
 - UoL** Set Analog Input High Voltage (Volts) 6.7
 - UoL** Set Analog Input Low Voltage (Volts) 6.6
 - UrTb** Variable Time Base 5.2
 - vJd** Watchdog Select (On/Off) 6.12
 - ZoNc** Number Zones Configured 6.18
 - ZoNc** Retransmit Zone Select 6.13
 - ZoNc** Zone Display Selection 6.2, 6.3

Declaration of Conformity

Power Series Power Controller



WATLOW Winona Inc.
1241 Bundy Boulevard
Winona, Minnesota 55987 USA

Declares that the following product:
Designation: **Power Series Power Controller**
Model Numbers: PC (1, 2, 3, 4, 8 or 9) (0 or 1) — (N20, N25, N30, F20, F25 or F30) (A, B or C) — (0 or 1) (0 or 1) (00 or AA-ZZ)
Classification: Solid State Power Controller, Class II, Pollution Degree III
Rated Voltage: 24 to 600V~
Rated Frequency: 50/60 Hz
Meets the essential requirements of the following European Union Directive(s) using the relevant section(s) of the normalized standards and related documents shown:

English

EN 61326: 1997 89/336/EEC Electromagnetic Compatibility Directive
Electrical equipment for measurement, control and laboratory use - EMC requirements (Group 1, Class A)
EN 61000-4-2: 1995 Electrostatic discharge
EN 61000-4-4: 1995 Electrical fast transients
EN 61000-4-8: 1993 Magnetic fields
EN 61000-4-3: 1996 Radiated immunity
EN 61000-4-6: 1996 Conducted immunity
EN 61000-4-5: 1995 Surge immunity
EN 61000-4-11: 1994 Voltage dips, short interruptions and voltage variations immunity
ENV 50204: 1995 Cellular phone
Note 1: Use of an external filter is required to comply with EN 61326 conducted emission limits. See page 2 (reverse) for information and instructions.
Note 2: A Line Impedance Stabilization Network (LISN), not a line clamp, was used for all emissions testing.

73/23/EEC Low-Voltage Directive

EN 50178: Electronic equipment for use in power installations

The Phase Angle Control Mode option for Power Series is excluded from this declaration.

Déclare que le produit suivant :
Designation : **Bloc de puissance Power Series**
Numéro de modèle : PC (1, 2, 3, 4, 8 ou 9) (0 ou 1) — (N20, N25, N30, F20, F25 ou F30) (A, B ou C) — (0 ou 1) (0 ou 1) (00 ou AA-ZZ)
Classification : Blocs de puissance à semi-conducteurs, Perturbations Classe II, Degré III
Tension nominale : 24 à 600 V ~
Fréquence nominale : 50/60 Hz
Sont conformes aux principales normes des directives de l'Union Européenne au regard de la (des) section(s) pertinente(s) des normes standards et documents apparentés présentés :

Français

EN 61326: 1997 89/336/EEC Directive de compatibilité électromagnétique
Appareillage électrique pour la mesure, la commande et l'usage de laboratoire — Prescriptions relatives à la Compatibilité Electro Magnétique (groupe 1, classe A)
EN 61000-4-2: 1997 Décharge électrostatique
EN 61000-4-4: 1995 Transitoires rapides électriques
EN 61000-4-8: 1993 Champs magnétiques
EN 61000-4-3: 1996 Immunité rayonnée
EN 61000-4-6: 1996 Immunité conduite
EN 61000-4-5: 1995 Essai d'immunité aux ondes de choc
EN 61000-4-11: 1994 Essais d'immunité relatifs aux creux de tension, coupures brèves et variations de tension
EN 61000-4-5: 1995 Insensibilité aux surtensions
EN 61000-4-11: 1994 Insensibilité aux chutes subites, aux courtes interruptions et aux variations de tension
ENV 50204: 1995 Téléphone cellulaire
Remarque 1: Il est nécessaire d'utiliser un filtre externe pour se conformer aux limites d'émission par conduction de la norme EN 61326. Voir les informations et instructions au verso.
Remarque 2: Un réseau de stabilisation d'impédance de ligne (RSIL), et non pas une limite de champ, a été utilisé pour tous les tests d'émission.

73/23/EEC Directive de basse tension

EN 50178: Equipement électro onique utilisé sur des installations électriques

Les blocs de puissance en version angle de phase ne sont pas couverts par cette déclaration.

Erklärt, daß das folgende Produkt:
Beschreibung: **Power Series Thyristor Leistungssteller**
Modellnummern: PC (1, 2, 3, 4, 8 oder 9) (0 oder 1) — (N20, N25, N30, F20, F25 oder F30) (A, B oder C) — (0 oder 1) (0 oder 1) (00 oder AA-ZZ)
Klassifikation: Halbleiter-Leistungssteller, Installationskategorie II, Emissionsgrad III
Nennspannung: 24-600 V~
Nennfrequenz: 50/60 Hz
Erfüllt die wichtigsten Normen der folgenden Anweisung der Europäischen Gemeinschaft unter Verwendung des wichtigen Abschnitts der normalisierten Spezifikationen und der untenstehenden einschlägigen Dokumente:

Deutsch

EN 61326: 1997 89/336/EEC EWG Elektromagnetische Verträglichkeit
Elektrogeräte zur Messung, Regelung und zum Laboreinsatz EMC-Richtlinien (Gruppe 1, Klasse A)
EN 61000-4-2: 1995 Elektrostatische Entladung
EN 61000-4-4: 1995 Elektrische schnelle Stöße
EN 61000-4-8: 1993 Magnetische Felder
EN 61000-4-3: 1996 Strahlungsimmunität
EN 61000-4-6: 1996 Leitungsimmunität
EN 61000-4-5: 1995 Spannungsstoßimmunität
EN 61000-4-11: 1994 Immunität gegen Spannungsgefälle, kurze Unterbrechungen und Spannungsabweichungen
ENV 50204: 1995 Mobiltelefon
Hinweis 1: Die Verwendung eines externen Filters kann erforderlich sein, um der EN 61326. Siehe Seite 2 (Rückseite) für Informationen und Anweisungen.
Hinweis 2: Zur Emissionsmessung wurde ein Leitungsimpedanz-Stabilisierungsnetzwerk (LISN), keine Klemme, eingesetzt.

73/23/EEC EWG Niederspannungsrichtlinie

EN 50178: Elektronische Geräte für die Verwendung bei Starkstrominstallationen

Leistungssteller mit Phasenanschnittsteuerung sind von dieser Erklärung ausgeschlossen.

Declara que el producto siguiente:
Designación: **Controlador de Potencia Power Series**
Números de Modelos: PC (1, 2, 3, 4, 8 o 9) (0 o 1) — (N20, N25, N30, F20, F25 o F30) (A, B o C) — (0 o 1) (0 o 1) (00 o AA-ZZ)
Clasificación: Controlador de Potencia de Estado Sólido, Clase II, Grado Contaminado III
Tensión nominal: De 24 a 600 V
Frecuencia nominal: 50/60 Hz
Cumple con los requisitos esenciales de las siguientes Directivas de la Unión Europea, usando las secciones pertinentes de las reglas normalizadas y los documentos relacionados que se muestran:

Español

EN 61326: 1997 89/336/EEC Directiva de Compatibilidad Electromagnética
Equipo eléctrico para medición control y uso en laboratorios - Requisitos de compatibilidad electromagnética (Grupo 1, Clase A)
EN 61000-4-2: 1995 Descarga electrostática
EN 61000-4-4: 1995 Perturbaciones transitorias eléctricas rápidas
EN 61000-4-8: 1993 Campos magnéticos
EN 61000-4-3: 1996 Inmunitad radiada
EN 61000-4-6: 1996 Inmunitad conducida
EN 61000-4-5: 1995 Sobretenión
EN 61000-4-11: 1994 Caídas de tensión, interrupciones breves y variaciones de tensión
ENV 50204: 1995 Teléfono portátil
Nota 1: Se requiere la utilización de un filtro externo para cumplir con la norma EN 61326 de límites de emisión conducidos. Léase la página 2 (reverso) para obtener más información e instrucciones.
Nota 2: En todas las pruebas de medición de emisiones se empleó una LISN (siglas en inglés de "red de estabilización de impedancia de línea) y no un estabilizador de línea.

73/23/EEC Directiva de baja tensión

EN 50178: Equipo electrónico para usar en instalaciones de generación de generia

Se excluye de esta declaración la opción de Modo de Control por Angulo de Fase del Controlador Power Series.

Jim Boigenzahn
Name of Authorized Representative

Winona, Minnesota, USA
Place of Issue

General Manager
Title of Authorized Representative

March 2002
Date of Issue

Signature of Authorized Representative

(2215)

Figure 1- Tank Filter, 1Ø 230V~
Abbildung 3. Tankfilter 1Ø; 230 V~
Figure 1 - Filtre cylindrique, 1Ø 230V~
Figura 1 - Filtro de tipo tanque, 1Ø 230V~

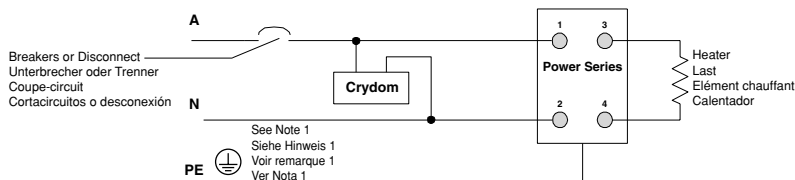
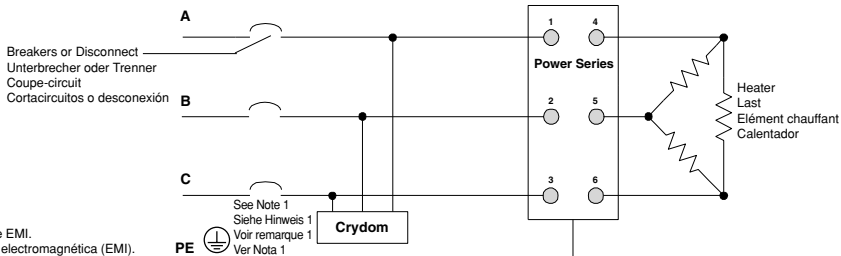

Figure 2- Tank Filter, 3Ø 440V~
Abbildung 3. Tankfilter 3Ø; 440 V~
Figure 2 - Filtre cylindrique, 3Ø 440V~
Figura 2 - Filtro de tipo tanque, 3Ø 440V~



Note 1: Protective earth (PE) connection required to minimize EMI.
Hinweis 1: Schutzerdung (PE) erforderlich, um EMI auf ein Minimum zu halten.
Remarque 1 : connexion de terre protectrice (PE) requise pour minimiser l'interférence EMI.
Nota 1: Conexión a tierra de protección (PE) requerida para minimizar la interferencia electromagnética (EMI).

Required (EN61326) External EMI Filters for Power Series with $\geq 6A$ Loads

An external EMI filter must be used in conjunction with the Power Series.

Watlow has verified that one type of filter will suppress electromagnetic interference (EMI) created by the Power Series power controller to within the EN61326 requirements:

- 1) A tank filter supplied by Crydom, installed across the power lines, suppresses EMI on the power lines. See Figures 1 and 2.

Wiring illustrations for the filters appear on the right. See Table 1 for the correct filter:

Description	Filter #	Watlow #
	Crydom	
1Ø; 230V~	1F25	14-0019
3Ø; 440V~	3F20	14-0020

Table 1 - Power Series EMI Filters

WARNING:

The tank filter specified may suppress desirable communications carried on power lines in the 150 to 250 kHz region. The filter may suppress carrier current such as that used for infant monitors and medical alert systems. Verify that suppressed carrier current or other desirable communications on power lines creates no hazard to people or property. Failure to observe this warning could result in damage to property, and injury or death for personnel.

WARNING:

All filter installation and wiring must be performed by qualified personnel, and conform to local and national electrical codes. Failure to observe this warning could result in damage to property, and injury or death for personnel.

Filtres externes EMI (EN61326) requis pour les Power Series à des charges de $\geq 6A$

Un filtre externe EMI doit être utilisé conjointement avec le Power Series.

Watlow s'est assuré qu'un type de filtre supprimera l'interférence électromagnétique (EMI) créée par le bloc de puissance Power Series, afin de se conformer aux exigences de la norme EN61326 :

- 1) Un filtre cylindrique, fourni par Crydom, installé sur les lignes secteurs, supprime l'interférence EMI des lignes secteurs. Voir les figures 1 et 2.

Les illustrations de câblage des filtres figurent à droite. Voir le tableau 1 sur l'utilisation du filtre approprié :

Description	N° de Filtre	N° Watlow
	Crydom	
1Ø; 230V~	1F25	14-0019
3Ø; 440V~	3F20	14-0020

Tableau 1 : Filtres EMI Power Series

IMPORTANT :

Le filtre spécifié peut supprimer les communications désirables de lignes secteurs se situant entre 150 et 250 kHz. Le filtre peut supprimer le courant porteur, tel que celui utilisé sur les appareils de surveillance des nouveau-nés et les systèmes d'alerte médicale. S'assurer que le courant porteur supprimé ou toute autre communication sur les lignes secteurs ne crée pas de danger pour les personnes ou les installations. La non-observation de cet avertissement peut entraîner des dommages matériels, des blessures ou même la mort.

IMPORTANT :

Toute l'installation et tout le câblage du filtre doivent être réalisés par un personnel qualifié et être en conformité avec les réglementations électriques locales et nationales. La non-observation de cet avertissement peut entraîner des dommages matériels, des blessures ou même la mort.

Erforderliche Entstörfilter gemäß EN 61326 für Power Series mit Laststrom $\geq 6A$.

Ein externer EMI-Filter sollte mit dem Power Series.

Watlow hat nachgewiesen, daß eine Filterart die elektro-magnetischen Störungen, die durch den Leistungssteller der Bauart Power Series hervorgerufen werden, der Norm EN61326 entsprechend unterdrückt.

- 1) Ein Tankfilter von Crydom, welcher über die Stromleitungen installiert wird, unterdrückt die elektro-magnetischen Störungen auf den Stromleitungen. Siehe Abbildungen 1 und 2.

Schaltenschemata für die Filter sind auf der rechten Seite zu sehen. Den richtige Filter finden Sie in Tabelle 1:

Beschreibung	Filter Nummer	Watlow Nummer
	Crydom	
1Ø; 230V~	1F25	14-0019
3Ø; 440V~	3F20	14-0020

Tabelle 1. Power Series EMI-Filter

WARNING:

Der angegebene Entstörfilter kann gewünschte Datenübertragungen im Bereich von 150 bis 250 kHz unterdrücken. Der Filter kann den Trägerstrom, der zum Beispiel bei Überwachungsgeräten für Kleinkinder oder medizinischen Warnsystemen verwendet wird, unterdrücken. Stellen Sie sicher, daß die Unterdrückung des Trägerstroms oder anderer gewünschter Datenübertragungen auf den Stromleitungen keine Gefahr für Personen oder Sachen darstellt. Eine Nichtbeachtung dieser Sicherheitsmaßnahme kann Sachschäden, Verletzungen oder den Tod zur Folge haben

WARNING:

Alle Filterinstallationen und Verdrahtungen müssen von qualifiziertem Personal durchgeführt werden und den bestehenden elektrischen Vorschriften entsprechen. Das Nichtbeachten dieser Warnung kann zu Sachschäden, Verletzungen oder zum Tod des Personals führen.

Filtros de interferencia electromagnética (EMI) externos (EN61326) requeridos para Power Series con cargas $\geq 6A$

Se debe usar un filtro de EMI externo junto con el Power Series.

La empresa Watlow ha verificado que hay un tipo de filtro que suprimen la interferencia electromagnética (EMI) creada por el controlador de potencia Power Series, y la mantiene dentro de los límites establecidos por los requerimientos de la EN61326:

- 1) Al instalarse un filtro de tipo tanque provisto por Crydom en paralelo con las líneas de alimentación eléctrica se suprime la interferencia electromagnética (EMI) en ellas. Véanse las Figuras 1 y 2.

Las ilustraciones de los cableados para los filtros aparecen en la derecha. Véase la Tabla 1 para seleccionar el filtro correcto:

Descripción	No. de filtro	No. Watlow
	Crydom	
1Ø; 230V~	1F25	14-0019
3Ø; 440V~	3F20	14-0020

Tabla 1 - Filtros de EMI de Power Series

¡Advertencia!

El filtro de tipo tanque especificado puede suprimir ciertas comunicaciones deseables que se envían por las líneas de alimentación eléctrica en frecuencias que van desde 150 a 250 kHz. El filtro puede suprimir corrientes portadoras, como las que se usan para monitores para bebés y sistemas de alarma médica. Verifique que la corriente portadora u otras comunicaciones deseadas suprimidas en las líneas de alimentación eléctrica no presenten peligros para las personas o la propiedad. El no observar esta advertencia puede causar daños a la propiedad, y lesiones o muerte del personal.

¡Advertencia!

Todas las instalaciones y conexiones de filtros deben ser realizadas por personal calificado y en conformidad con los códigos locales y nacionales. El no observar esta advertencia puede causar daños a la propiedad, y lesiones o muerte del personal.

Power Series Software Map

Display Loop

(See the Power Series User's Manual)

Setup Page

AL9a Control Algorithm

AL9a	Power Control Algo Select	-----
Ftb	Fixed Time Base	-----
UC	Line Voltage Comp	-----

CEr1 Control Zone 1

In	Input Signal Method Select	-----
dFLE	Default Numeric Input Sig	-----
nnR ₋	Set Analog Input Lo Cur	-----
nnR ₊	Set Analog Input Hi Cur	-----
UoL ₋	Set Analog Input Lo Volt	-----
UoL ₊	Set Analog Input Hi Volt	-----
Lrn _R	Learn Input Learn Req	-----
bL _U	Baseline Volt Read/Adj	-----
Lrn _U	Baseline Volt Learn Req	-----
TYPE	Load Type Select	-----
rATE	Max Rate of Change	-----
SoFE	Soft Start Time	-----

OPt1 Options Zone 1

Hbo	Heater Bakeout Select	-----
P7in	HBO Select Time	-----
HbC	HBO Current Trip	-----
CL _i	Cur Limit Select	-----
CL _A	Cur Limit Set Point	-----
LoL ₋	Lo Tol Set Point	-----
LoL ₊	Hi Tol Set Point	-----
IndF	Induct Load Factor Req	-----
iCur	Inductive Current	-----

CEr2 Control Zone 2

In	Input Signal Method Select	-----
dFLE	Default Numeric Input Sig	-----
nnR ₋	Set Analog Input Lo Cur	-----
nnR ₊	Set Analog Input Hi Cur	-----
UoL ₋	Set Analog Input Lo Volt	-----
UoL ₊	Set Analog Input Hi Volt	-----
Lrn _R	Learn Input Learn Req	-----
bL _U	Baseline Volt Read/Adj	-----
Lrn _U	Baseline Volt Learn Req	-----
rATE	Max Rate of Change	-----
SoFE	Soft Start Time	-----

OPt2 Options Zone 2

Hbo	Heater Bakeout Select	-----
P7in	HBO Select Time	-----
HbC	HBO Current Trip	-----
CL _i	Cur Limit Select	-----
CL _A	Cur Limit Set Point	-----
LoL ₋	Lo Tol Set Point	-----
LoL ₊	Hi Tol Set Point	-----
IndF	Induct Load Factor Req	-----
iCur	Inductive Current	-----

CEr3 Control Zone 3

In	Input Signal Method Select	-----
dFLE	Default Numeric Input Sig	-----
nnR ₋	Set Analog Input Lo Cur	-----
nnR ₊	Set Analog Input Hi Cur	-----
UoL ₋	Set Analog Input Lo Volt	-----
UoL ₊	Set Analog Input Hi Volt	-----
Lrn _R	Learn Input Learn Req	-----
bL _U	Baseline Volt Read/Adj	-----
Lrn _U	Baseline Volt Learn Req	-----
rATE	Max Rate of Change	-----
SoFE	Soft Start Time	-----

OPt3 Options Zone 3

Hbo	Heater Bakeout Select	-----
P7in	HBO Select Time	-----
HbC	HBO Current Trip	-----
CL _i	Cur Limit Select	-----
CL _A	Cur Limit Set Point	-----
LoL ₋	Lo Tol Set Point	-----
LoL ₊	Hi Tol Set Point	-----
IndF	Induct Load Factor Req	-----
iCur	Inductive Current	-----

ALr Alarms Configuration

AL9c	Active Relay State	-----
GLbL	Global Alarm	-----
OPEn	Heater Open Alarm	-----
LoL	Heater To Alarm	-----
OT	Heat Sink Over Temp Alarm	-----
ALC	Heat Sink Over Temp Alarm Temp	-----
Line	Line Loss Alarm	-----
P _b AL	Phase Bal Alarm	-----
L _b AL	Load Bal Alarm	-----
L _d P	Load Bal Percent	-----
F _r E9	Freq Out of Tol Alarm	-----
UC	Volt Comp Alarm	-----
OU	Over Volt Alarm	-----
C _w Ad	Comms Watchdog Alarm	-----

COM7 Comms Configurations

Addr	Unit Address Select	-----
baud	Unit Baud Rate Select	-----
Wdd	Watchdog Select	-----
SEC	Watchdog Timeout	-----
P _w Jr	Watchdog Fail Output Pwr Sel	-----

RETr Retransmit Configuration

CF9	Retrans Select	-----
TYPE	Retrans Type Select	-----
PhAS	Retrans Phase Select	-----
ZonE	Retrans Zone Select	-----
Cur ₋	Min Amps Retrans	-----
Cur ₊	Max Amps Retrans	-----
HUR ₋	Min kVA Retrans	-----
HUR ₊	Max kVA Retrans	-----
re ₋ C ₋	Set Retrans Output Lo Cur	-----
re ₋ C ₊	Set Retrans Output Hi Cur	-----
re ₋ U ₋	Set Retrans Output Lo Volt	-----
re ₋ U ₊	Set Retrans Output Hi Volt	-----

Factory Page

DATA System Data Manipulation

baUP	Backup Data Set	-----
dFLE	Default Data Set	-----
rESE	Restore Data Set	-----
nUOL	Enable NVOL Storage	-----

Loc Global/Menu Lockouts

GLoc	Global Lockout	-----
CEr	Control Setup Menus Lock	-----
OPt	Options Setup Menus Lock	-----
ALr	Alrms Setup Menu Lock	-----
COM7	Comms Setup Menu Lock	-----
RETr	Retrans Setup Menu Lock	-----
C _i n	Analog Input Menu Lock	-----
C _r ctr	Retrans Menu Lock	-----
DATA	Sys Data Menu Lock	-----
d _i AG	Diag Menu Lock	-----

Info Unit Information

S _n ₊	Unit Serial # Hi Digits	-----
S _n ₋	Unit Serial # Lo Digits	-----
DATE	Mfg Date	-----
HUER	Hardware Version	-----
SUER	Software Version	-----
SbLd	Software Build #	-----
r _A U	Unit Volt Rating	-----
r _A ER	Unit Curt Rating	-----
ZonC	# Zones	-----
OPt	Installed Options	-----
C	Heat Sink Temp	-----
ALC	Heat Sink Alarm Temp	-----
SdC	Safety Shutdown Temp	-----
H _i C	Hi Heat Sink Temp	-----
H _r S ₊	Accum Hours	-----
H _r S ₋	Accum Hours	-----

d_iAG Diagnostics

Ad	Select A/D Channel	-----
CnES	Read Selected A/D Counts	-----

Line Loss Alarms:

L _{LA} 1	Most Recent	-----
L _{LA} 1	Line Loss	-----
L _{LA} 1	Alarm Type	-----
L _{LA} 2	Previous	-----
L _{LA} 2	Line Loss	-----
L _{LA} 2	Alarm Type	-----
L _{LA} 3	Least Recent	-----
L _{LA} 3	Line Loss	-----
L _{LA} 3	Alarm Type	-----

d _i SP	Display Test	-----
In	Select Discrete Input	-----
URL	Read Selected Input Value	-----
RETr	Retrans Set Test Word	-----

The Factory Page also includes calibration parameters that are not necessary for everyday use of the controller. Calibration parameters and procedures are explained in the Power Series User's manual.

Enter your settings on a photocopy of this page.

How to Reach Us



Quality and Mission Statement:

Watlow Winona will be the world's best supplier of industrial temperature control products, services, and systems by exceeding our customers', employees', and shareholders' expectations.

Contact

Your Authorized Watlow Distributor is:

- Phone: +1 (507) 454-5300.
- Fax: +1 (507) 452-4507.
- For technical support, ask for an Applications Engineer.
- To place an order, ask for Customer Service.
- To discuss a custom option, ask for the Power Series Product Manager.

Warranty

The Watlow Power Series is warranted to be free of defects in material and workmanship for 36 months after delivery to the first purchaser for use, providing that the units have not been misapplied. Since Watlow has no control over their use, and sometimes misuse, we cannot guarantee against failure. Watlow's obligations hereunder, at Watlow's option, are limited to replacement, repair or refund of purchase price, and parts which upon examination prove to be defective within the warranty period specified. This warranty does not apply to damage resulting from transportation, alteration, misuse, or abuse.

Returns

- Call or fax Customer Service for a Return Material Authorization (RMA) number before returning a controller.
- Put the RMA number on the shipping label, along with a written description of the problem.
- A restocking charge of 20% of the net price is charged for all standard units returned to stock.

Watlow Power Series User's Manual

Watlow Winona, 1241 Bundy Boulevard, P.O. Box 5580, Winona, Minnesota USA 55987-5580,
Phone: +1 (507) 454-5300, Fax: +1 (507) 452-4507