



Series L

User's Manual



Series L - Temperature Limit



**TOTAL
CUSTOMER
SATISFACTION**
3 Year Warranty



ISO 9001

Registered Company
Winona, Minnesota USA

1241 Bundy Boulevard., Winona, Minnesota USA 55987
Phone: +1 (507) 454-5300, Fax: +1 (507) 452-4507 <http://www.watlow.com>



Safety Information

We use note, caution and warning symbols throughout this book to draw your attention to important operational and safety information.

A “NOTE” marks a short message to alert you to an important detail.

A “CAUTION” safety alert appears with information that is important for protecting your equipment and performance. Be especially careful to read and follow all cautions that apply to your application.

A “WARNING” safety alert appears with information that is important for protecting you, others and equipment from damage. Pay very close attention to all warnings that apply to your application.

The safety alert symbol,  (an exclamation point in a triangle) precedes a general CAUTION or WARNING statement.

The electrical hazard symbol,  (a lightning bolt in a triangle) precedes an electric shock hazard CAUTION or WARNING safety statement.



**CAUTION or
WARNING**

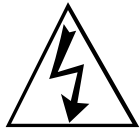

**Electrical
Shock Hazard**

CAUTION or WARNING

Technical Assistance

If you encounter a problem with your Watlow controller, review your configuration information to verify that your selections are consistent with your application: inputs, outputs, alarms, limits, etc. If the problem persists, you can get technical assistance from your local Watlow representative (see back cover), by e-mailing your questions to wintechsupport@watlow.com or by dialing +1 (507) 494-5656 between 7 a.m. and 5 p.m., Central Standard Time (CST). Ask for for an Applications Engineer. Please have the following information available when calling:

- Complete model number
- System wiring information
- Series L Limit User’s Manual

Warranty

These controllers are manufactured by ISO 9001-registered processes and are backed by a three-year warranty.

Return Material Authorization (RMA)

1. Call Watlow Customer Service, (507) 454-5300, for a Return Material Authorization (RMA) number before returning any item for repair. We need this information:
 - Ship to address
 - Contact name
 - Method of return shipment
 - Detailed description of the problem
 - Name and phone number of person returning the product.
 - Bill to address
 - Phone number
 - Your P.O. number
 - Any special instructions
2. Prior approval and an RMA number, from the Customer Service Department, is needed when returning any unused product for credit. Make sure the RMA number is on the outside of the carton, and on all paperwork returned. Ship on a Freight Prepaid basis.
3. After we receive your return, we will examine it and try to verify the reason for the return.
4. In cases of manufacturing defect, we will enter a repair order, replacement order or issue credit for material returned.
5. To return products that are not defective, goods must be in new condition, in the original boxes and they must be returned within 120 days of receipt. A 20 percent restocking charge is applied for all returned stock controls and accessories.
6. If the unit is unrepairable, it will be returned to you with a letter of explanation.
7. Watlow reserves the right to charge for no trouble found (NTF) returns.

The Series L Limit user’s manual is copyrighted by Watlow Winona, Inc., © April 2003 with all rights reserved. (2359)

1

Overview

Watlow's Series L family of temperature limit controllers* provide an economical limit controller solution for applications where thermal system protection is needed.

The Series L limit controller is added to applications to prevent over or under temperature conditions. The limit provides safety assurances against instances where a thermal runaway condition occurs as a result of a failed sensor, controller or output device.

The Series L limit controller is recommended for any application where thermal system runaway could result in large product scrap costs, damage to system equipment, potential fire hazard or risk to personnel. All Series L limit controllers are Factory Mutual and CSA approved. They are also approved as a temperature limiter (TB) under DIN 3440.

These controllers are available with or without an operator interface and can be ordered in square 1/8th DIN panel mount, din rail mount, open board or potted module design configurations.

The microprocessor design platform provides improvements in the performance, repeatability, and accuracy offered by Watlow's current line of basic control products.

The Series LV includes an operator interface to allow viewing and selection of the limit set point. A red four character, seven segment LED displays the limit set point. The limit set point selection is made with a continuous turn, velocity sensitive rotary encoder. Push to Set operation reduces accidental limit set point adjustments. Limit set point operating range temperature values are customer definable in the product configuration part number.

The Series LF offers fixed limit set points. These units are supplied without an operator interface. Limit set point temperature values are customer definable in the product configuration part number.

The features and performance of these products make them ideally suited for a wide range of industrial limit control applications in the food preparation, industrial machinery, packaging and plastic markets.

Watlow's Series L limit controllers include industry leading service, support and a 3-year warranty.

*Also available, Series C, an on-off temperature controller version.

Features and Benefits

Four Character LED Display

- Improves limit set point adjustment accuracy.

Fixed or Adjustable Limit Set Points

- Tamper proof operation.
- Control flexibility.

Push to Set

- Reduce accidental limit set point adjustments.

Multiple Mounting Options

- Minimizes installation time.

High or Low Limit Operation

- Application flexibility.

Fahrenheit or Celsius Operation with Indication

- Application flexibility.

Sensor Break Protection

- Provides positive system shutdown.

Agency Approvals

- Meets requirements for agency certification.

Micro Processor Based Technology

- Accurate and repeatable protection.

Stock to Four Day Delivery

2

Installation

Installing the Open Board Controller

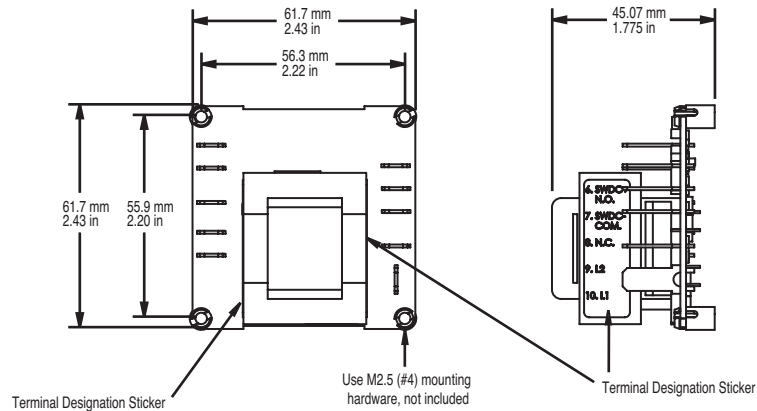

Figure 2a

1. Locate and drill four 3.2 mm (0.125 in) holes in the desired panel location. See Figure 2a for hole locations.
2. Mount the controller using four M2.5 (#4) screws.

Installing the Potted Controller

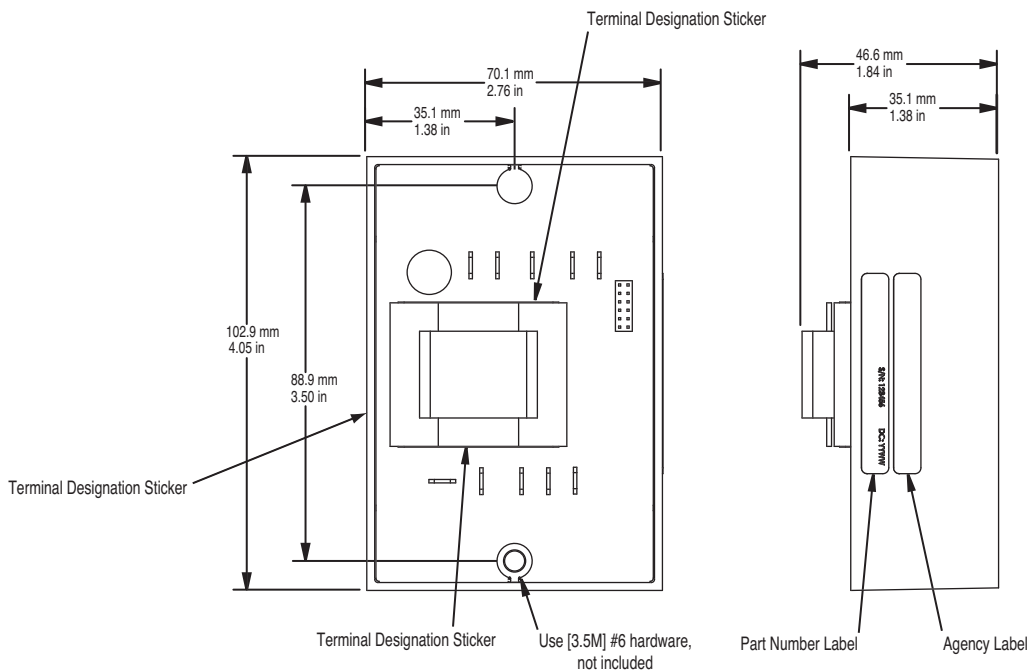

Figure 2b

1. Drill two 5 mm (0.187 in) diameter holes in the desired panel location. See Figure 2b for hole locations.
2. Mount the controller using two M3.5 (#6) screws.

Installing the DIN Rail Mount Controller

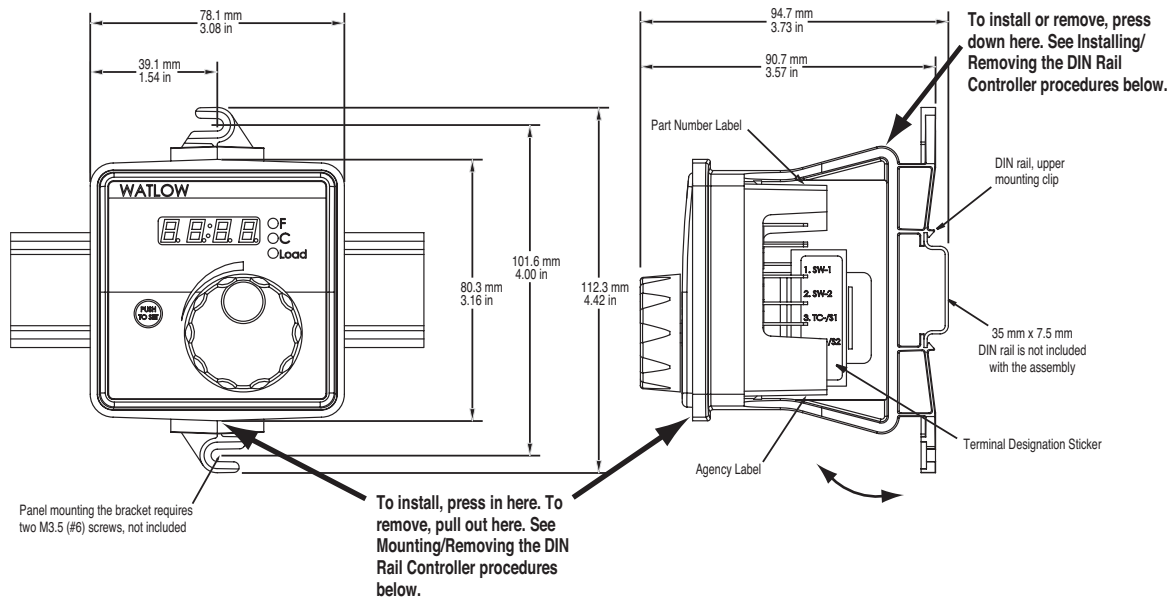

Figure 3a
Sub-Panel Mounting

1. Using the controller as a location template, mark both mounting holes.
2. Drill and tap two 2.7 mm (0.106 in) diameter holes in the desired panel location. See Figure 3a above for hole locations.
3. Mount the controller using two M3.5 (#6) screws.

DIN Rail Mounting

1. Place the DIN rail upper mounting clip on the top edge of the DIN rail. See Figure 3a. DIN rail spec, DIN 50022, 35 mm x 7.5 mm (1.38 in x 0.30 in).
2. Press down firmly on the top back edge of the DIN rail bracket and push in on the bottom, front edge of the bracket, . The controller “snaps” securely onto the rail. See Figure 3a. If the controller does not snap on, check to see if the DIN rail is bent. Minimum clipping distance is 34.8 mm (1.37 in), the maximum is 35.3 mm (1.39 in).

Removing the DIN Rail Controller

1. Remove power from the system.
2. Remove all the wiring connections from the back of the controller.
3. While pressing down on the top, back edge of the DIN rail bracket, pull forward on the bottom, front edge of the DIN rail bracket. See Figure 3a.

Removing the Controller from the DIN Rail Bracket

1. Remove power from the system.
2. Remove all the wiring connections from the back of the controller.
3. Remove the DIN rail bracket from the DIN rail.
4. Insert a flat blade screwdriver between the DIN rail bracket and the case. Rotate the screwdriver to release the DIN rail bracket hooks from the ridges on the case, while firmly pushing the controller out the front of the DIN rail bracket. Alternate back and forth between the top and then the bottom. Be sure to support the controller as it comes out of the bracket. See Figure 3b.

⚠ Caution: FM approval requires limit switches to be suitably enclosed to restrict casual user adjustment.

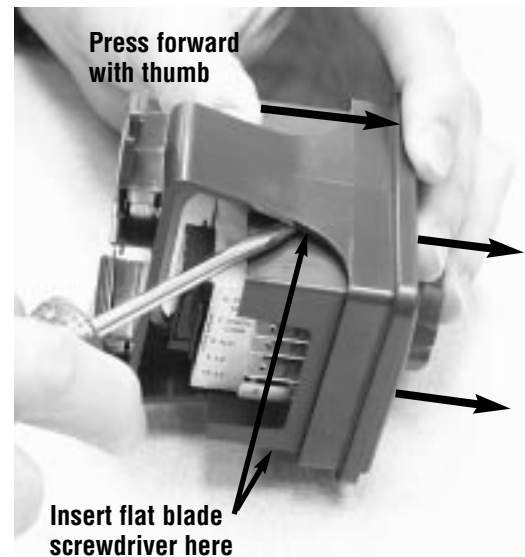

Figure 3b

Installing the Square 1/8 DIN Panel Mount Controller

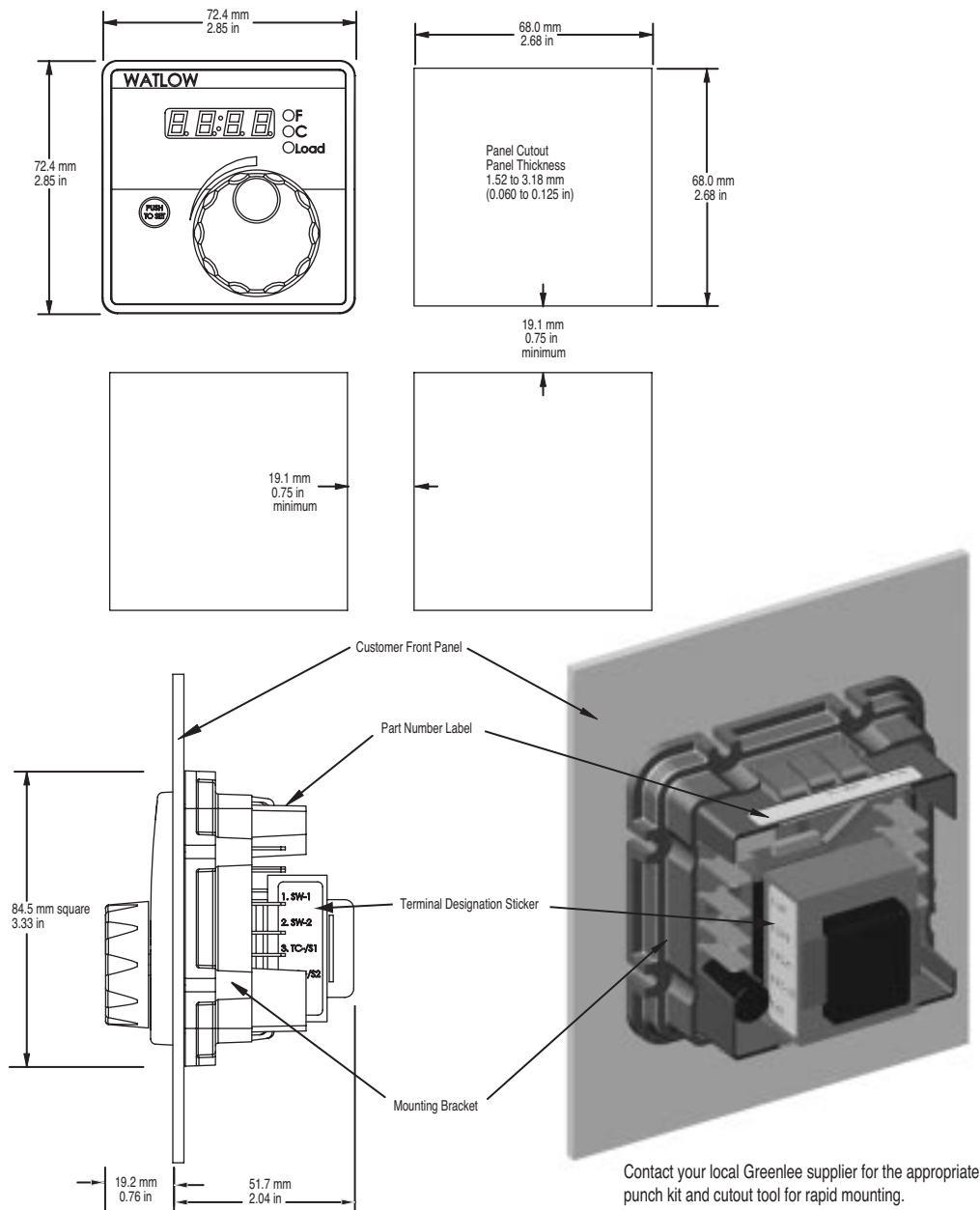

Figure 4

1. Make the panel cutout using the mounting dimensions above.
2. Remove mounting bracket from the back of the controller.
2. Insert the controller into the panel cutout.
3. While pressing the bezel firmly against the panel, slide the mounting bracket over the back of the controller. Be sure the levers on the mounting bracket line up with the teeth on the case.
4. Press the bracket up to the back of the panel. The controller should fit tightly in the panel cutout.

Removing the Panel Mount Square 1/8 DIN Controller

1. Remove power from the system.
2. Remove all the wiring connections from the back of the controller.
3. Slide a thin, wide tool (putty knife) under all three mounting tabs, top then bottom, while pushing forward on the back of the case. Be ready to support the controller as it slides out of the panel cutout.



Caution: FM approval requires limit switches to be suitably enclosed to restrict casual user adjustment.

3

Wiring



Warning:

Use National Electric (NEC) or other country-specific standard wiring and safety practices when wiring and connecting this controller to a power source and to electrical sensors or peripheral devices. Failure to do so may result in damage to equipment and property, and/or injury or loss of life.

Note: Insulated quick connect terminals required.

For terminals 1, 2, 6, 7, 8, 9, and 10, AMP P/N 3-520406-2 or equivalent recommended. Use Amp crimp tool P/N 58078-3, insert 90391-3.

For terminals 3, 4, and 5, AMP P/N 2-520405-2 or equivalent recommended. Amp crimp tool P/N 58078-3, insert 58079-3.



Caution: FM approval requires limit switches to be suitably enclosed to restrict casual user adjustment.

The terminals on the back of the Series L limits are the same for all of the package styles. They are 6.3 mm (0.25 in) quick connect, push on style terminals.

Check the part number to determine your hardware configuration. Refer to the wiring diagrams appropriate for your controller's configuration.

All outputs are referenced to a de-energized state.

Wiring Guidelines

1. Use the correct thermocouple type per the model number on the case sticker of the unit. See dimension drawings for sticker locations.
 - Use correct thermocouple polarity. Red is usually negative.
 - If you must extend thermocouple leads, use thermocouple extension wire to minimize errors.
 - Be sure you have good crimp connections on all wire connections.
 - Insulate the thermocouple mounting from the mounting surface to prevent heat migration input errors.
 - Thermocouple leads should be routed separately from any high voltage lines.
 - Long lead lengths create electrical resistance. When using a two-wire RTD, there will be an additional 2.6° C (4.7° F) error for every 1Ω of lead length resistance. That resistance when added to the resistance of the RTD element, can result in erroneous input to the temperature controller.
2. In electrically-noisy environments (heavy switching contactors, motors, solenoids, etc.), use shielded thermocouple lead wire with the shield connected at the sensor end only.
3. Use a separate thermocouple to maintain the limit function of this controller; do not parallel thermocouple input from the primary controller.
4. All wiring and fusing must conform to the National Electric Code (NEC) NFPA70 and any other locally applicable codes.
5. Fuse the independent load voltage on the L1 (hot) side and connect it to the common (C) side of the relay.



Warning:

Use National Electric (NEC) or other country-specific standard wiring and safety practices when wiring and connecting this controller to a power source and to electrical sensors or peripheral devices. Failure to do so may result in damage to equipment and property, and/or injury or loss of life.



WARNING: If high voltage is applied to a low-voltage controller, irreversible damage will occur.

Note: Insulated quick connect terminals required.

For terminals 1, 2, 6, 7, 8, 9, and 10, AMP P/N 3-520406-2 or equivalent recommended. Use Amp crimp tool P/N 58078-3, insert 90391-3.

For terminals 3, 4, and 5, AMP P/N 2-520405-2 or equivalent recommended. Amp crimp tool P/N 58078-3, insert 58079-3.

Figure 6a — AC Power Wiring

- Nominal voltage options:
 - 24V~ (ac)
 - 120V~ (ac)
 - 230 to 240V~ (ac)

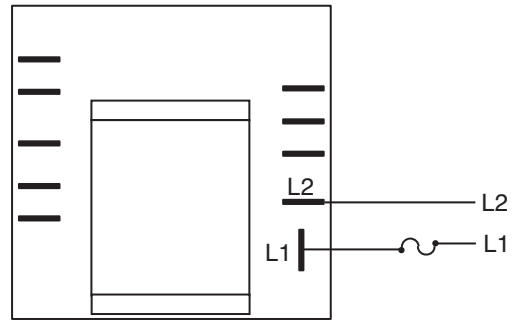

Figure 6b — Thermocouple Input

Thermocouples are polarity sensitive. The negative lead (usually red) must be connected to TC-.

- Input impedance: >10 MΩ

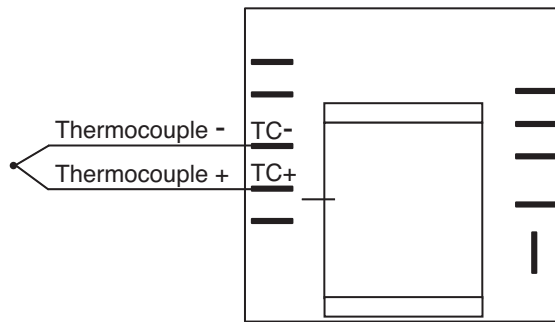
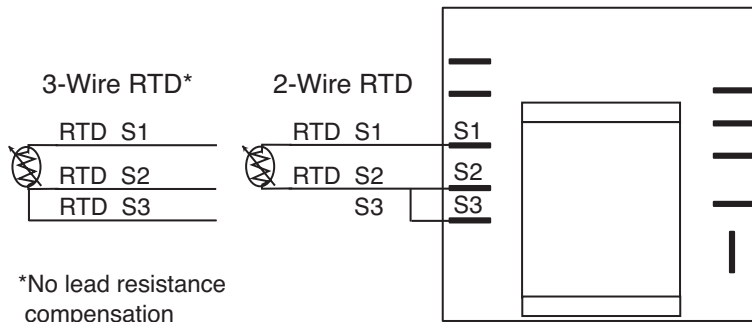

Figure 6c — RTD Input

(100 Ω Platinum DIN curve 0.00385 Ω/Ω/°C)

- Terminals S2 and S3 must be shorted for a two-wire RTD
- Nominal excitation current: 125 μA



*No lead resistance compensation



Warning:

Use National Electric (NEC) or other country-specific standard wiring and safety practices when wiring and connecting this controller to a power source and to electrical sensors or peripheral devices. Failure to do so may result in damage to equipment and property, and/or injury or loss of life.

Note: Use of an external reset switch may affect FM approval. Only the use of a momentary N.O. switch is valid for approval.

Note: Insulated quick connect terminals required.

For terminals 1, 2, 6, 7, 8, 9, and 10, AMP P/N 3-520406-2 or equivalent recommended. Use Amp crimp tool P/N 58078-3, insert 90391-3.

For terminals 3, 4, and 5, AMP P/N 2-520405-2 or equivalent recommended. Amp crimp tool P/N 58078-3, insert 58079-3.

Quencharc Note: Switching pilot duty loads (relay coils, solenoids, etc.) with the mechanical relay output option requires use of an R.C. suppressor.

Watlow carries the R.C. suppressor Quencharc brand name, which is a trademark of ITW Paktron. Watlow Part No. 0804-0147-0000.

Figure 7a — External Reset Switch

- Momentary normally open (N.O.), dry contact closure

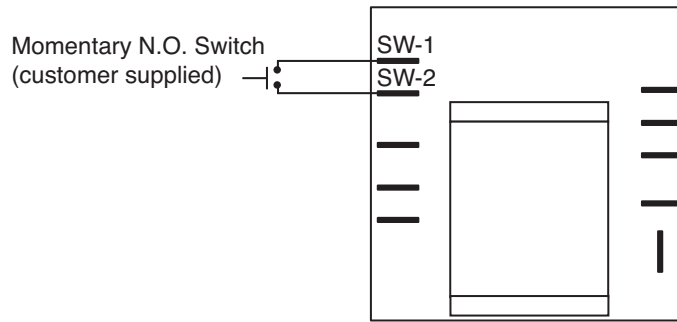
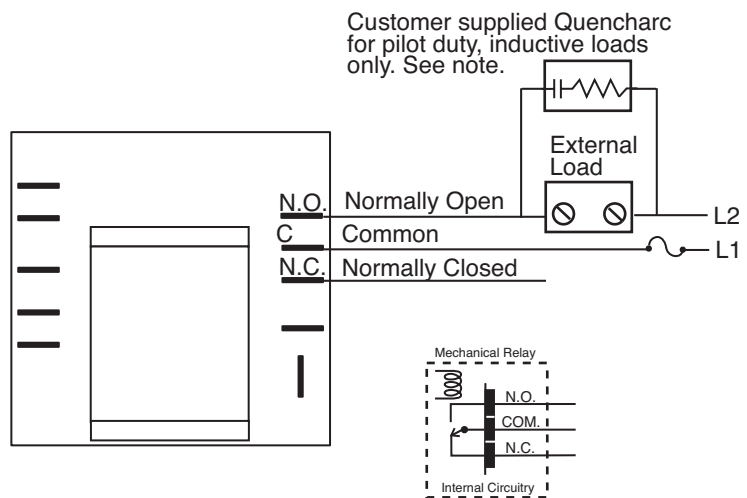

Figure 7b — Mechanical Relay Output

- Form C contacts
- 8 A, resistive
- 250 VA pilot duty, 120/240V~ (ac), inductive
- 240V~ (ac) maximum
- 30V= (dc) maximum
- See Quencharc note
- For use with ac or dc
- Minimum load current 100 mA
- Output does not supply power



System Wiring Examples

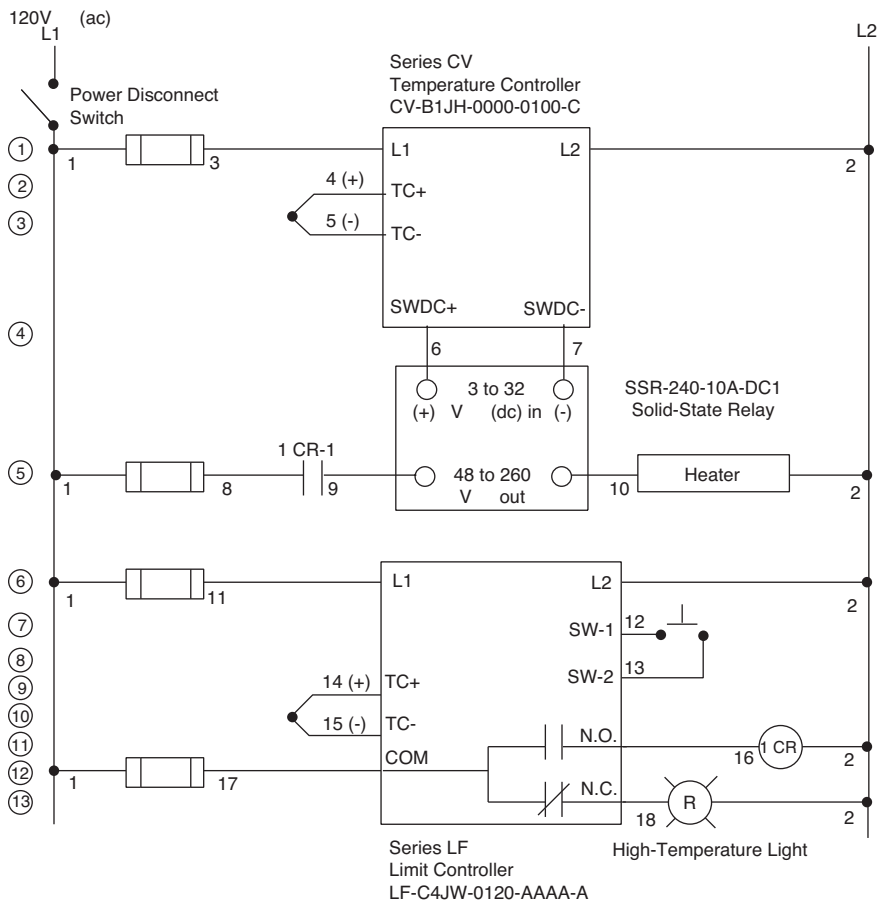
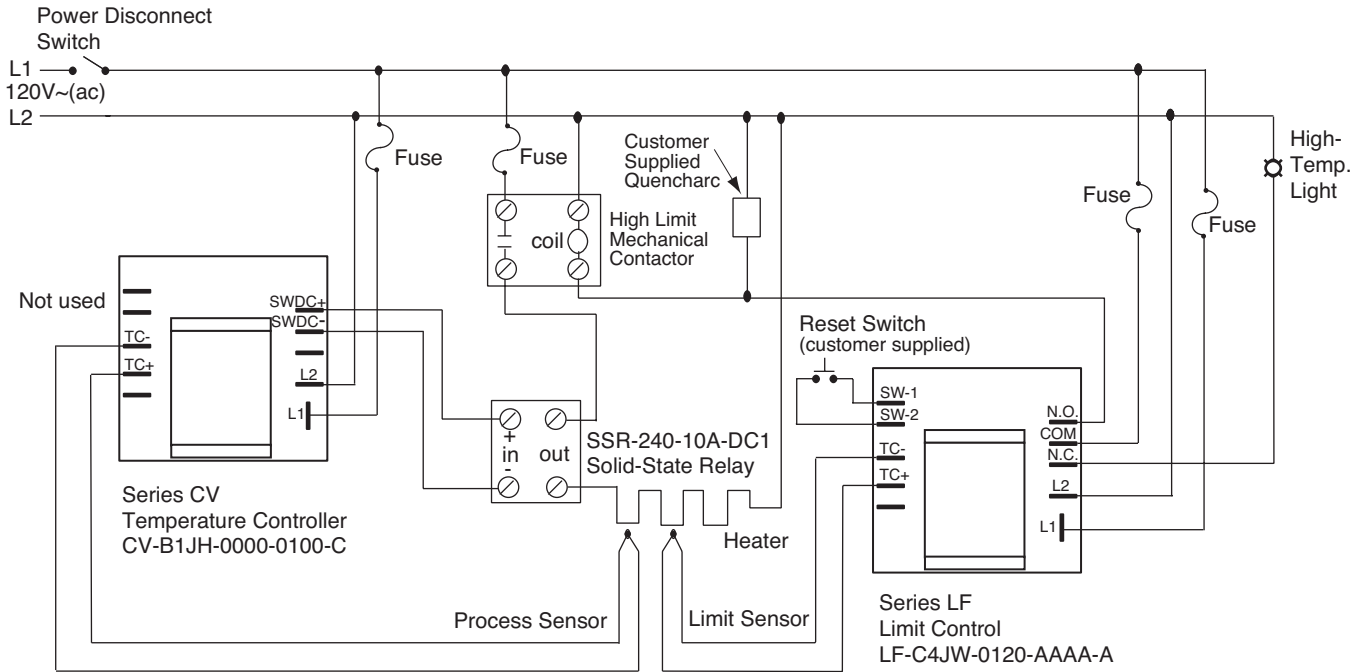

Figure 8 — System Wiring Examples

4

User Interface

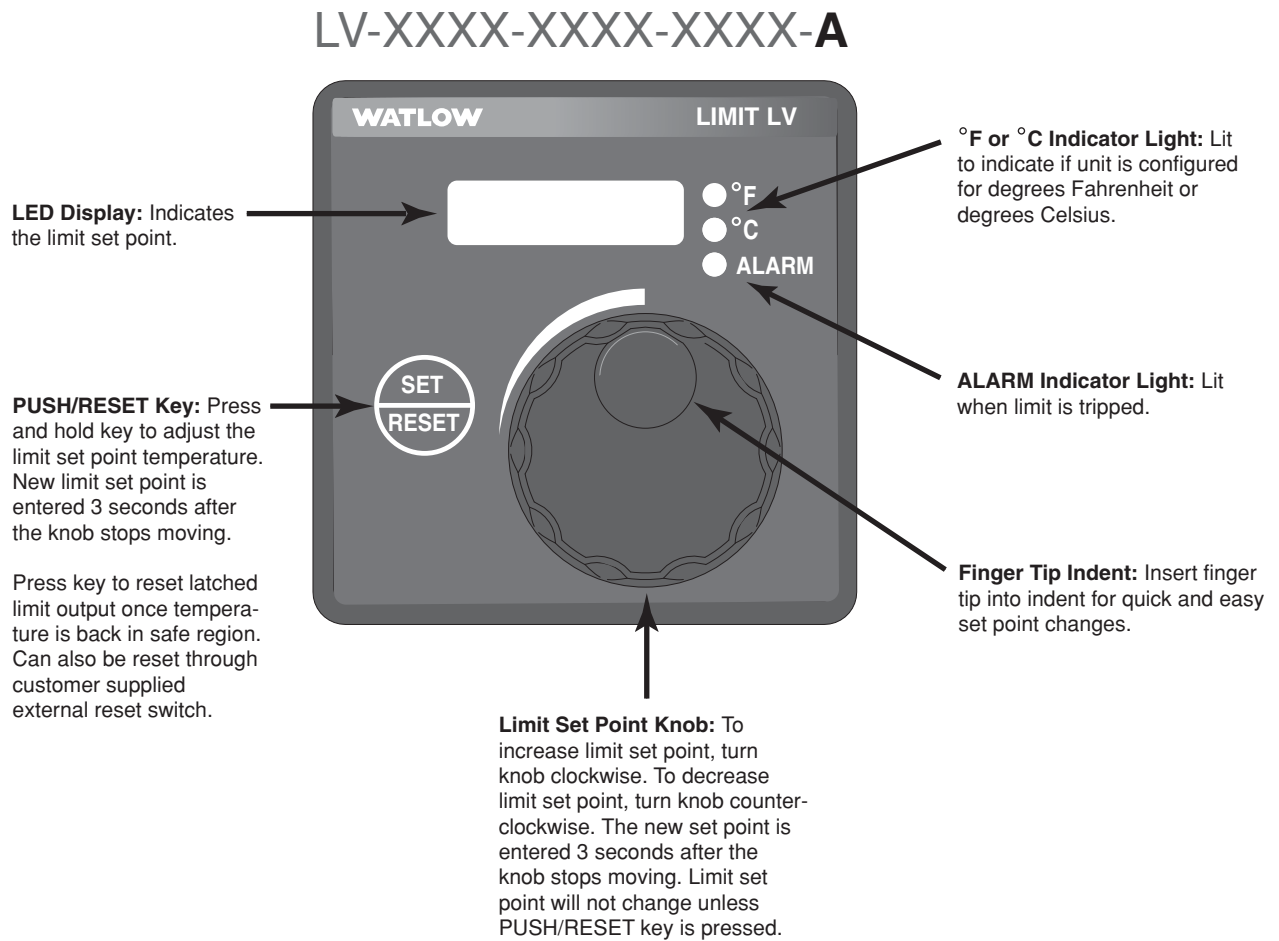

Figure 9b — Variable Limit Set Point, Standard Interface



Caution: FM approval requires limit switches to be suitably enclosed to restrict casual user adjustment.

Troubleshooting

<p>On indicating limits, the display is not illuminated.</p>	<ul style="list-style-type: none"> • Power supply switch off. • Fuse blown. • Breaker tripped. • Safety interlock door switch activated. • Wiring incorrect or open. • Power supply voltage incorrect. • Defective limit. 	<ul style="list-style-type: none"> • Turn switch on. • Replace fuse (check cause of failure). • Reset breaker (check cause of failure). • Close door. • Check wiring. • Verify input power • Repair or replace limit.
<h2>Troubleshooting thermocouple inputs</h2>		
<p>Temperature reading is incorrect, showing a sensor error, [Er. In], or ALARM LED is switching at the wrong temperature.</p>	<ul style="list-style-type: none"> • Sensor or limit may be bad. Sensor connections may be bad. • Ambient temperature in the control cabinet is over 70°C. • Ground loop problem. Can occur when using a switched DC output and a grounded thermocouple. 	<ul style="list-style-type: none"> • Place a jumper wire across the thermocouple input terminals. The display should indicate ambient temperature. If it does, the limit is OK. - For high limit: Start with limit set point above ambient temperature, ALARM LED should be off. Decrease limit set point until ALARM LED goes on. It should be approximately ambient temperature. - For low limit: Start with limit set point below ambient temperature, ALARM LED should be off. Increase limit set point until ALARM LED goes on. It should be approximately ambient temperature. • Measure temperature in cabinet to ensure it is below 70C. Vent cabinet or add fans if necessary. • Remove power from the system. Use an ohm meter to measure resistance between output DC- and the thermocouple sheath. If there is continuity, replace sensor with an ungrounded thermocouple.
<p>Temperature seems to be decreasing, but actual process is increasing.</p>	<ul style="list-style-type: none"> • Thermocouple polarity is reversed. In the US, red wire insulation denotes the negative wire. 	<ul style="list-style-type: none"> • Check thermocouple connections. All connections, including extension wire must maintain the correct polarity. Correct polarity problems.
<p>Temperature seems to be reading low and not increasing while actual process temperature is increasing.</p>	<ul style="list-style-type: none"> • Sensor is bad. Thermocouple is shorted. 	<ul style="list-style-type: none"> • Check thermocouple connections. Check thermocouple wire insulation to make sure it is not damaged, causing the wires to short (making a new junction).
<p>Temperature seems to be offset from actual process temperature, or the ALARM LED switches on at the wrong temperature. The offset changes with changes in process temperature.</p>	<ul style="list-style-type: none"> • Copper wire was used instead of thermocouple extension wire. Connectors of metals different than thermocouple metal were used to splice or make connections. 	<ul style="list-style-type: none"> • Check thermocouple connections. Check to make sure that only thermocouple extension wire of the correct type was used to extend thermocouple leads. Replace if necessary.

Indication	Probable Cause(s)	Corrective Action
Troubleshooting RTD inputs		
<p>Temperature reading is incorrect, showing a sensor error, [Err In], or ALARM LED is switching at the wrong temperature.</p>	<ul style="list-style-type: none"> • Sensor or limit may be bad. Sensor connections may be bad. • Ambient temperature in the control cabinet is over 70°C (158°F). • Sensor connections may be bad. Excessive lead wire resistance. 	<ul style="list-style-type: none"> • Place a 110 ohm resistor across the sensor input terminals. - For high limit: Start with limit set point above ambient temperature, ALARM LED should be off. Decrease limit set point until ALARM LED goes on. It should be approximately ambient temperature. If it does, the limit is OK. Sensor or connections may be bad. - For low limit: Start with limit set point below ambient temperature, ALARM LED should be off. Increase limit set point until ALARM LED goes on. It should be approximately ambient temperature. If it does, the limit is OK. Sensor or connections may be bad. • Measure temperature in cabinet to ensure it is below 70°C (158°F). Vent cabinet or add fans if necessary. • Check sensor connections. Measure lead wire resistance. There will be a 2.6C (4.7°F) error for every ohm of lead wire resistance.
Troubleshooting limit outputs		
<p>ALARM is not tripped when it should be. ALARM LED is not on (relay is energized in safe condition, N.O. contact is closed and N.C. contact is open).</p>	<ul style="list-style-type: none"> • Temperature appears to be incorrect. See input troubleshooting. • Limit set point is not set correctly. 	<ul style="list-style-type: none"> • See input troubleshooting. • Verify limit set point setting.
<p>ALARM is tripped when it should not be. ALARM LED is on (relay is de-energized in limit condition, N.O. contact is open and N.C. contact is closed).</p>	<ul style="list-style-type: none"> • Limit output is tripped (latched). • Output wiring is incorrect. • Temperature appears to be incorrect, see input troubleshooting. • Limit set point is not set correctly. • Limit output is defective. 	<ul style="list-style-type: none"> • Press RESET key to reset limit. • Verify wiring. Relay outputs act as a switch, they do not source power. • See input troubleshooting. • Verify limit set point setting. • Repair or replace limit.
<p>Limit output signal is on when it should not be on. Load LED is on.</p>	<ul style="list-style-type: none"> • Temperature reading is incorrect on display of indicating controls or limit, see input troubleshooting. • Set point is not set correctly 	<ul style="list-style-type: none"> • See input troubleshooting. • Verify limit set point setting.
<p>Limit load is on when it should be off. ALARM LED is off.</p>	<ul style="list-style-type: none"> • Power switching device (mechanical relay, contactor, etc.) is shorted. Limit output shorted. • Output wiring is incorrect. 	<ul style="list-style-type: none"> • Remove wires from output of limit to input of power switching device. If load is still on, replace power switching device. If load turns off, replace limit or sensor. See input troubleshooting.. • Verify wiring.

Specifications

(2361)

Controller

- Microprocessor based, limit controller.
- Nominal switching hysteresis, typically 1.7°C (3°F)
- High or low limit, factory selectable.
- Latching output requires manual reset upon over or under temperature condition.
- Manual or automatic reset on power loss, factory selectable.
- Internal front panel or external customer supplied momentary reset switch.
- Input filter time: 1 second.

Operator Interface (model dependent)

- Four digit , 7 segment LED displays, .28" high.
- °F or °C indicator LED.
- ALARM indicator LED.
- Continuous turn, velocity sensitive rotary encoder for limit set point adjustment.
- Front panel SET/RESET key on variable set point models.
- No operator interface on fixed set point models.

Standard Conditions For Specifications

- Rated line voltage, 50 to 60Hz, 0 to 90% RH non-condensing, 15-minute warm-up.

Calibration ambient range: 25°C (77°F) ±3°C

Sensor Input

Thermocouple

- Grounded or ungrounded.
- Type E, J, K, T thermocouple types.
- >10 MΩ input impedance.
- 250 nV input referenced error per 1Ω source resistance.

RTD

- 2-wire platinum, 100 Ω.
- DIN curve (.00385 curve).
- 125 μA nominal RTD excitation current.

Input Accuracy Span Range

Type E:	-200 to 800°C or -328 to 1,470°F
Type J:	0 to 750°C or 32 to 1,382°F
Type K:	-200 to 1,250°C or -328 to 2,282°F
Type T:	-200 to 350°C or -328 to 662°F
RTD (DIN):	-200 to 800°C or -328 to 1,472°F

Thermocouple Input

- Calibration accuracy: ±1% of input accuracy span, ±1° at standard conditions and actual calibration ambient.

Exception: Type T, ±2.4% of input accuracy span for -200 to 0°C (-328 to 32°F)

- Temperature stability: ±0.3 degree per degree change in ambient.

RTD Input

- Calibration accuracy: ±1% of input accuracy span ±1° at standard conditions and actual calibration ambient.
- Temperature stability: ±0.2 degree per degree change in ambient

Allowable Operating Ranges

Type E:	-200 to 800°C or -328 to 1,470°F
Type J:	-210 to 1,038°C or -346 to 1,900°F
Type K:	-270 to 1,370°C or -454 to 2,500°F
Type T:	-270 to 400°C or -454 to 750°F
RTD (DIN):	-200 to 800°C or -328 to 1,472°F

External Reset Switch

- Momentary, dry contact closure. See wiring section.

Output Types

Electromechanical Relay, Form C

- Minimum load current: 100 mA.
- 8 A @ 240V~ (ac) or 30V= (dc) maximum, resistive.
- 250 VA pilot duty, 120/240V~ (ac) maximum, inductive.
- Use RC suppression for inductive loads.
- Electrical life 100,000 cycles at rated current.

Agency Approvals

Series LF, potted version

- UL®873, UL 197, UL 991 recognized temperature limit for cooking industry.
- ANSI Z21.23 Gas appliance thermostat approval.
- DIN 3440 - Temperature control and limiting devices for heat generating systems, Type (TB).
- CSA C22.2#24 Approved temperature regulator for cooking industry.
- FM Class 3545 temperature limit switches.
- CE - see Declaration of Conformity.

Series LF, non-potted version and Series LV

- UL 873 recognized temperature regulator.
- UL 197 reviewed for use in cooking appliances.
- ANSI Z21.23 Gas appliance thermostat approval.
- DIN 3440 - Temperature control and limiting devices for heat generating systems.
- CSA C22.2#24 approved limit control.
- FM Class 3545 temperature limit switches.
- CE - see Declaration of Conformity.

Terminals

- 6.3 mm (0.25 in) quick connect, push on terminal. See wiring section for terminal recommendations.

Power

- 24V~ (ac) +10%; -15%; 50/60 Hz, $\pm 5\%$
- 120V~ (ac) +10%; -15%; 50/60 Hz, $\pm 5\%$
- 230 to 240V~ (ac) +10%; -15%; 50/60 Hz, $\pm 5\%$
- 10VA maximum power consumption.
- Data retention upon power failure via nonvolatile memory.

Operating Environment

- 0 to 70°C (32 to 158°F)
- 0 to 90% RH, non-condensing.
- Storage temperature: -40 to 85°C (-40 to 185°F)

Dimensions

- DIN Rail model can be DIN rail or chassis mount DIN rail spec, DIN 50022, 35 mm x 7.5 mm (1.38 in x 0.30 in)

Style	Width	Height	Depth
Open board	61.7 mm (2.43 in)	61.7 mm (2.43 in)	45.1 mm (1.78 in)
Potted	70.1 mm (2.76 in)	102.9 mm (4.05 in)	46.6 mm (1.84 in)
DIN Rail	78.1 mm (3.08 in)	112.3 mm (4.42 in)	90.7 mm* (3.57 in)
Square 1/8 DIN Panel	72.4 mm (2.85 in)	72.4 mm (2.85 in)	Behind panel 51.7 mm (2.04 in)

*Depth including DIN rail, 94.7 mm (3.73 in)

Note: These specifications are subject to change without prior notice.

Glossary

automatic power reset — A feature in latching limit controllers that does not recognize power outage as a limit condition. When power is restored, the output is re-energized automatically, as long as the temperature is within limits.

latched output — Limit control output latches in de-energized condition when over or under temperature condition occurs and cannot be reset unless temperature drops below set point.

limit or limit controller — A highly reliable, discrete safety device (redundant to the primary controller) that monitors and limits the temperature of the process or a point in the process. When temperature exceeds or falls below the limit set point, the limit controller interrupts power through the load circuit. A limit controller can protect equipment and people when it is correctly installed with its own power supply, power lines, switch and sensor.

manual power reset — A feature in latching limit controllers that does recognize power outage as a limit condition. When power is restored, the output is not re-energized automatically, even if the process is within limits. An operator must use the reset key or switch to manually re-energize the output on power up.

manual reset — A feature on a limit controller that requires human intervention to return the limit to normal operation after a limit condition has occurred.

safety limit — An automatic limit intended for use in applications where an over-temperature fault may cause a fire.

Ordering Information and Model Numbers (2363)

Limit Control, LED display, Front panel reset switch		L	V	-	-	-	-	-	-	-	-	-	-	-	-	-	-	-
Set Point Type																		
V	Variable Limit Set Point																	
Line Voltage																		
C	120V~ (ac)																	
E	230-240V~ (ac)																	
G	24V~ (ac)																	
Controller Package																		
1	Panel Mount, Square 1/8 DIN																	
2	DIN Rail Mount																	
Sensor and Scale																		
H	Type J -346 to 1900 Degrees F																	
J	Type J -210 to 1038 Degrees C																	
K	Type K -454 to 2500 Degrees F																	
L	Type K -270 to 1370 Degrees C																	
M	Type T -454 to 750 Degrees F																	
N	Type T -270 to 400 Degrees C																	
P	100Ω RTD -328 to 1472 Degrees F																	
R	100Ω RTD -200 to 800 Degrees C																	
S	Type E -328 to 1470 Degrees F																	
T	Type E -200 to 800 Degrees C																	
Limit Type																		
U	High Limit, Manual Power Reset																	
W	High Limit, Auto Power Reset																	
Y	Low Limit, Manual Power Reset																	
Z	Low Limit, Auto Power Reset																	
Low Limit Set Point Range Limit *																		
XXXX	Low limit set point operating range value**																	
High Limit Set Point Range Limit *																		
XXXX	High limit set point operating range value																	
Overlay/Custom Option																		
A	Standard																	

*Note: Set point ranges must fall within the sensor operating range.

**Note: A (-) is used in the left digit of the operating range to indicate negative values.

Notes

Declaration of Conformity

Series L

Watlow Winona, Inc.
1241 Bundy Blvd.
Winona, MN 55987 USA

Declares that the following product:

Designation: **Series L**

Model Numbers: **LF** - (C, E or G)(1, 2, 3 or 4)(any letter)(U, W, Y or Z) - (any four numbers or - and three numbers) - (AAAA) - may be followed by additional numbers or letters
LV - (C, E or G)(1 or 2)(any letter)(U, W, Y or Z) - (any four numbers or - and three numbers) - (any four numbers) - may be followed by additional numbers or letters

Classification: LF and LV = Temperature Limiter (TB) Installation Category II, Pollution degree II

Rated Voltage: 24, 120, 230/240 V~ (ac)

Rated Frequency: 50 or 60 Hz

Rated Power Consumption: 10VA maximum

Meets the essential requirements of the following European Union Directives by using the relevant standards shown below to indicate compliance.

89/336/EEC Electromagnetic Compatibility Directive

EN 61326: 1997 With A1, 1998:A2:2001: Electrical equipment for measurement, control and laboratory use – EMC requirements (Industrial Immunity, Class B Emissions).

EN 61000-4-2:	1995 A1, A2:2001:	Electrostatic Discharge Immunity
EN 61000-4-3:	1997 A1, A2:2001:	Radiated Field Immunity
EN 61000-4-4:	1995 A1:2001:	Electrical Fast-Transient / Burst Immunity
EN 61000-4-5:	1995 A1, A2:2001:	Surge Immunity
EN 61000-4-6:	1996 A1, A2, CRGD1:2001:	Conducted Immunity
EN 61000-4-11:	1994:	Voltage Dips, Short Interruptions and Voltage Variations Immunity
EN 61000-3-2:	ED.2. 2000:	Harmonic Current Emissions
EN 61000-3-3:	1995 With A1, 1998:	Voltage Fluctuations and Flicker

73/23/EEC Low-Voltage Directive

EN 60730-1:2000 With A11:2002 and EN 60730-2-9:2002: Safety Requirements of electrical equipment for measurement, control and laboratory use. Part 1: General requirements

Raymond D. Feller III

Name of Authorized Representative

Winona, Minnesota, USA

Place of Issue

General Manager

Title of Authorized Representative

April 2003

Date of Issue



Signature of Authorized Representative

How to Reach Us

TOTAL
CUSTOMER
SATISFACTION
3 Year Warranty

Your Authorized Watlow Distributor:

Corporate Headquarters in the U.S.:

Watlow Electric Manufacturing Co.
12001 Lackland Road
St. Louis, Missouri, USA 63146
Telephone: +1 (314) 878-4600
Fax: +1 (314) 878-6814

Europe:

Watlow GmbH
Industriegebiet Heidig
Lauchwasenstr. 1, Postfach 1165
Kronau 76709 Germany
Telephone: +49 (0) 7253-9400 0
Fax: +49 (0) 7253-9400-44

Watlow France S.A.R.L.
Immeuble Somag, 16 Rue Ampère,
Cergy Pontoise CEDEX 95307 France
Telephone: +33 (1) 3073-2425
Fax: +33 (1) 3073-2875

Watlow Italy S.R.L.
Via Meucci 14,
20094 Corsico MI
Italy
Telephone: +39 (02) 4588841
Fax: +39 (02) 458-69954

Watlow Limited
Robey Close, Linby Industrial Estate,
Linby Nottingham England, NG15 8AA
Telephone: +44 (0) 115 9640777
Fax: +44 (0) 115 9640071

Latin America:

Watlow de México
Av. Fundición #5,
Col. Parques Industriales,
Querétaro, Qro. México CP-76130
Telephone: +52 (442) 217-6235
Fax: +52 (442) 217-6403

Asia/Pacific:

Watlow Australia Pty., Ltd.
23 Gladstone Park Drive,
Tullamarine, Victoria 3043 Australia
Telephone: +61 (39) 335-6449
Fax: +61 (39) 330-3566

Watlow China, Inc.
179, Zhong Shan Xi Road
Hong Qiao Cointek Bldg, Fl. 4, Unit P
Shanghai 200051 China
Telephone: +86 (21) 6229-8917
Fax: +86 (21) 6228-4654

Watlow Japan Ltd. K.K.
Azabu Embassy Heights 106,
1-11-12 Akasaka,
Minato-ku, Tokyo 107-0052 Japan
Telephone: +81 (03) 5403-4688
Fax: +81 (03) 5403-4646

Watlow Korea Co., Ltd.
3rd F. Taehong Bldg.
20-6, Seocho-gu Yangjae-dong
Seoul, Korea 137-130
Telephone: +82 (2) 575-9804
Fax: +82 (2) 575-9831

Watlow Malaysia Sdn Bhd
38B Jalan Tun Dr Awang
11900 Bayan Lepas
Penang Malaysia
Telephone: +60 (4) 641-5977
Fax: +60 (4) 641-5979

Watlow Singapore Pte. Ltd.
Ayer Rajah Crescent
#03-23, Ayer Rajah Industrial Estate
Singapore 139949
Telephone: +65 773 9488
Fax: +65 778 0323

Watlow Electric Taiwan
10F-1 No. 189
Chi-Shen 2nd Road,
Kaohsiung, Taiwan
Telephone: +886 (7) 288-5168
Fax: +886 (7) 288-5568